



2020 HANDBOOK

January 2020

All enquiries should be addressed to:

The Auto-Cycle Union Ltd., ACU House, Wood Street, Rugby, Warwickshire CV21 2YX.

Telephone: 01788 566400; Fax: 01788 573585

www.acu.org.uk admin@acu.org.uk

The contents of this Handbook are Copyright and must not be reproduced without written consent from the Auto-Cycle Union Ltd. The various regulations contained herein become effective as at 1st January 2020. This publication supersedes previous editions.

The ACU is the internationally recognized National Governing Body for motorcycle sport in the British Isles (less Northern Ireland). Formed in 1903, the ACU has a long tradition in the world of motorcycle sport being a founder member of the World Governing Body, the Federation Internationale Motocyclisme (FIM). The ACU has a major role in furthering the interests of motorcycle sport on a global basis. Domestically, the ACU provides for all forms of motorcycle sport ranging from Road Racing to all disciplines of Off Road activity and has successfully organized world class events such as Moto GP, World Superbikes, the Isle of Man TT Races and the Motocross of Nations.

The ACU aims to ensure that all people irrespective of their age, gender, disability, race, ethnic origin, creed, colour, social status or sexual orientation, have a genuine and equal opportunity to participate in motorcycle sport at levels in all roles. The ACU fully supports youth activity in all disciplines and through the ACU Academy, some of our young riders go on to become British, European and World Champions in their chosen sport.

GDPR Statement

This statement explains how The Auto-Cycle Union Limited (ACU) handles and uses information we collect regarding our Members (Competitors/Officials/Associate Members). In broad terms, we use your information to process your ACU Competition Licence and/or Officials licence and also to assist with the process of you entering an ACU permitted event as well as maintaining our own records on each Member individually.

The controller for your personal information is The Auto-Cycle Union Ltd, ACU House, Wood Street, Rugby, Warwickshire, CV21 2YX. The Data Protection Officer for the ACU is located at the address given above and can be contacted by telephoning 01788 566400 or by email: marie@acu.org.uk. The Data Protection Officer should be contacted if you have any concerns about how the ACU is managing your personal information, or if you require advice on how to exercise your rights as outlined in this statement.

The person within the ACU otherwise responsible for data protection at the time of issue, and the person who is responsible for monitoring compliance with relevant legislation in relation to the protection of personal information, is the Data Protection Coordinator (marie@acu.org.uk).

The legal basis for processing your personal information is that it is necessary in order for you to obtain an ACU competition licence/an Officials licence/an Associate Members licence and to assist you with an entry to an ACU permitted event. We will retain your information for the time you have a valid licence with the ACU or until you request us to do otherwise.

We will hold your name, address, email address, phone number and other relevant contact details you provide to us, and will use this information to maintain contact with you and to process your licence/entry as outlined above. We retain this information in our Licence database whilst you have a licence (as outlined above) with the ACU, providing you with details about future event provision services.

We do not share personal information with third parties. If you have concerns or queries about any of these purposes, or how we communicate with you, please contact us at the address given above.

We operate CCTV at ACU Head Office for security purposes.

You have the right: to ask us for access to, rectification or erasure of your information; to restrict processing (pending correction or deletion); to object to communications or direct marketing; and to ask for the transfer of your information electronically to a third party (data portability). Some of these rights are not automatic, and we reserve the right to discuss with you why we might not comply with a request from you to exercise them.

You retain the right at all times to lodge a complaint about our management of your personal information with the Information Commissioner's Office at <https://ico.org.uk/concerns/>

Published by: The Auto-Cycle Union Ltd.

Designed by: The Ark Design & Print.

The products advertised within this Handbook are not necessarily endorsed by the ACU.

Front cover photograph: Bradley Freeman at the EnduroGP in Uhlířské Janovice, Czech Republic. Photo credit: Dario Agrati

ACU and The Auto-Cycle Union are trading names of The Auto-Cycle Union Limited. Registered under Company No. 00134679; Registered Office: ACU House, Wood Street, Rugby, Warwickshire CV21 2YX



Patron

Hrh The Prince Philip, Duke of Edinburgh Kg Kt Om Gbe Ac Qso

President Emeritus

The Rt Hon The Lord Jopling DL

Vice President

C. Moram
T. Fairbrother
D Ryder
D. Willoughby

Honorary Vice President

Lt Col (Retd) E. P. Bartlett
M. Mellish

Chairman

R. Humphrey

Auditors Magma Chartered Accountants

General Secretary N. Doctor **Honorary**

Members of the ACU

D. D. Banks
Lt Col (Retd) E. P.
Bartlett
E. Bellars
A. Brownlie
F. Carter
R. Collins

J. Coles
W.Evans Mbe
T.
Fairbrother
M. Francis
E. Jones
A. Noel

A. Penny
D. Ryder
R. W. Smith
W. A. Smith
K. Sprayson
J. Stone

THE ACU MISSION

- To pursue the interests of motorcycling while protecting and promoting the needs of members.
- To facilitate British Motorcycle Sport in the most accommodating, de-regulated and user led manner possible.
- To make British Motorcycle Sport happen.

Disclaimer

The Auto-Cycle Union Ltd., its Directors and Officers accept no liability in respect of loss or damage occasioned directly or indirectly as a result of the publication of the ACU Handbook or Web Site. It is a matter for each individual to satisfy themselves as to the suitability of any Course, Facility or Product (including Machinery and Clothing) offered by Clubs, Venues, Landowners, Advertisers or Manufacturers and for such individuals to ensure that adequate insurance and medical arrangements have been made to protect their interest with regard to any activity undertaken.

contents

section one THE ACU

Committees & panels	8
Auto-Cycle Union Limited structure	13
Who should I contact at the ACU?	14
Non-territorial clubs	15
Recognised promoters	18
Recognised associations	19
Useful addresses	20
Centres/Regions	21
Timekeepers & timing equipment	56
Technical officials	58
Sound level control	60
Fuel regulations – National ACU	63
ACU approved protective helmets and visors	66
Competition licence/Trial registration	68
One event licences	68
One event trials licences	68
Associate membership	69
ACU Benevolent Fund	70
Price List	72
LASU	73
Training Department	74
LARA	75
Land Use Advisory Service	77
The Motor Vehicles (Off Road Events) Regulations 1995	78
ACU Environmental Code	80
APPENDIX A Recommended standards for the provision of sanitary facilities at ACU events	84
Equal opportunities/sports equity policy statement	85
Insurance	86
Serious accident checklist	92
Medical services	93

section two **STANDING REGULATIONS**

Motocross	102
Enduro	138
Hare and Hounds/Cross Country	165
Trials	170
Track Racing	203
Road Racing	236
Supermoto	294
Drag Race	313
Hillclimb and Sprint	347
Pocket Bike	367
Scooter	377

section three

ACU Historical information	416
Champions	418

section four

National Sporting Code of the ACU	423
-----------------------------------	-----

section five

Rules of the Union	479
--------------------	-----

Note *No discrimination is intended where references are made to 'he', rather than 'she', throughout this Handbook.*

COPYRIGHT

(To be printed in all official programmes)

All literary matters in the official programme including the list of competitors and their racing numbers is copyright and any person making illegal use thereof will be prosecuted. It is also a condition of admission to any event held under an ACU Permit that no part of the meeting can be filmed or video recorded and/or video transmitted in any way without the written consent of the promoters/organisers and/or the ACU except for the sole purpose of private enjoyment.

sectionone

THE

NATIONAL COUNCIL**CHAIRMAN – R. Humphrey (2021) 11**

Shepherds Avenue, Earley, nr Reading,
Berks, RG6 1AY. Tel: 07850 598886
royh.acu@btinternet.com

ACU Cheshire & North Wales C. Berisford,
38 Wybunbury Road, Willaston,
Nantwich, CW5 7JE. Tel: 07748
234357

chris.berisford@sky.com

ACU Cornwall Thomas Newton, 75 Agar Road,
St Austell, Cornwall, PL25 3AF. Tel: 079508
94966
thomasnewton28@hotmail.co.uk

ACU Eastern Mrs V.Hearn, 25 Quinton
Road, Needham Market, Suffolk
IP6 8BP. Tel/Fax: 01449 721042
jack.vera7@btinternet.com

ACU East Midland M. Jessup, 54 Monks
Road, Binley Woods, Coventry
CV3 2BS. Tel: 02476 544463
mark.jessup@btinternet.com

ACU East South Wales Mr Derek
Smith, Crosswinds, 13 Julians
Close, Gelligar, Caerphilly, CF82
8DT.

Tel: 01443 556407/07971 153903

derek.acu.eastsouthwales@gmail.com

ACU East Yorks Ian Morley, Glenshiel, Tame
Bridge, Stokesley TS9 5LG. Tel: 07808
923364,
ianmorley210@hotmail.co.uk

ACU Isle of Man Mrs B. Crellin, Shilley Gniebe,
Ballachurry Road, Greeba, Isle of Man
IM4 3LE. Tel: 01624 801726 fin-
bren@manx.net

ACU Midland Mr D. Smith, The Willows,
Cursley Lane, Shenstone, Kidderminster,
Worcs, DY10 4DX. Tel: 01527 592797
dave@globalpump.co.uk

ACU Mid Wales Miss J Hockly, 1 Plas y Bryn
Bungalow, Llanfair Road, Newtown,
Powys SY16 3JY. Tel/Fax: 01686
626370 jess_hockly@yahoo.co.uk
www.midwalesdirtrack.com

ACU Northern R Wilson, 14 Undercliff
Road, Kendal, Cumbria LA9 4PS. Tel:
01539 728565
mec27@btinternet.com

ACU North Eastern I Reavely, 35 Columbia
Terrace, Blythe, Northumberland, NE24
3JZ ianreavely007@btinternet.com

ACU North Western R. Livesey, 37 Doodstone
Avenue, Lostock Hall, Preston, Lancs,
PR5 5TY. Tel: 01772 753433/07806
627343

hondabobs@btinternet.com

ACU South Eastern Jamie Clarke, 12
Sarsen Heights, Walderslade,
Chatham, Kent, ME5 9HW. Tel:
0770969 9092
jamie_clarke28@hotmail.com

ACU Southern B. New, 6 Coleridge Gardens,
Cowplan, Waterlooville, Hants PO8
8LS. Tel: 02392 645114

ACU South Midland Miss M Bird. Tel: 07773
064796 mellie.bird@ntlworld.com

ACU South Western Mrs S Pattison, 6
Churchfields, Wincanton, Somerset BA9
9AJ. Tel: 01963 33001

ACU Wessex N. Steadman, 11 Watson
Avenue, Bristol BS4 3SG. Tel: 07505
187071

nick_steadman@msn.com

ACU Western Miss J. Jones, Woodlands,
Kempley Green, Dymock Gloucester,
GL18 2BW. Tel: 01531 890691/07775
524805

jennie.jones2@tiscali.co.uk

ACU West South Wales G. Heywood,
81 Alexander Road, Gorseinon,
Swansea SA4 4NU. Tel: 01792 893457
grahamheywood@live.com

ACU Yorkshire Mike Washington. Tel:
07730 572683

mikewashington@sky.com

ACU Scotland C Mackenzie, 28 West Main
Street, Uphall, West Lothian EH52
5DW. Tel: 01506 858354 Fax: 01506
855792

office@sacu.co.uk

Non-Territorial Board M. Dommett,
British Motorcycle Racing Club
Limited, Unit D2, Seedbed Centre,
Davidson Way, Romford, Essex.
RM7 0AZ. Tel: 01708 720305. Mob:
07970
963572.

mikedommett@hotmail.com

www.bemsee.net

Non-Territorial Board Sally Russell,
Houndshill Cottage, Banbury Road,
Evington, Stratford upon Avon, Warks.
CV37

7NS. Tel: 01789 740866/07710 435086

russell.sally4@gmail.com

*Year in brackets indicates expiry of term of
office at 31st December.*

ACU LTD DIRECTORS

CHAIRMAN – R Humphrey (2021) 11

Shepherds Avenue, Earley, nr Reading,
Berks, RG6 1AY. Tel: 07850 598886
royh.acu@btinternet.com

**J. Collins (2020) 52 Margam Road, Margam,
Port Talbot, West Glamorgan SA13
2BW. Tel: 01639 882241 Fax: 01639
773470 johncollinsemail@yahoo.co.uk**

**R. Hanks (2020) 50 Lyndhurst Road,
Erdington, Birmingham B24 8QS. Tel:
0121 686 3799 royacu97@gmail.com**

**B. Higgins (2022) Sunnycote, Marytavy,
Tavistock, Devon PL19 9QB.
Tel: 01822 810336/07793 494793
brianhiggins424@gmail.com**

**Dr P D King (2022) c/o ACU Road Race
Dept, ACU House, Wood Street,
Rugby, CV21 2YX. Tel: 01788
566400
paul.king@acu.org.uk**

**S. McCauley (2021) 1 Brecon Close,
Wansbeck Manor, Ashington,
Northumberland NE63 0HT. Tel: 07747
864384 steve.mx@aol.com**

**I. Murphy (2020) Thie Roarbrae, 11 Sileau
Curn Park, Kirk Michael, Isle of Man IM6
1EH. Tel: 01624 878394 murf@manx.net**

**T Robinson (2022) Wayback, Sherfield
Green, Sherfield-on-Loddon, Hook,
Hampshire, RG27 0EE. Tel: 07817
131821 tristan@tristanrobinson.co.uk**

**A. Steele (2021) 22 Church Street,
Billesden, Leicestershire LE7 9AE. Tel:
07889 862077
tandj22@btinternet.com**

**A Summers (2021) 101 Friar Park Road,
Wednesbury, West Midlands WS10
0JR aws.30acu@outlook.com**

*Company Secretary: Neil Doctor. Tel: 01788
566434 neil@acu.org.uk*

pANEL OF ADJUDICATORS

**A. F. E. Bellars (2021) 12 Rosehill Park,
Emmer Green, Reading, Berks RG4 8XE.
Tel: 0118 947 0837
bellars@virginmedia.com**

**J. Coles (2021) 88 Wheatley Road,
Garsington, Oxford OX44 9DR. Tel:
01865 361735**

**A. Foskew (2021) 9 Ebenezer Close, Witham,
Essex CM8 2HX. Tel: 01376 517169
alanfoskew29@btinternet.com**

**E. Jones (2021) 18 Chapel Street,
Astwood Bank, Redditch B96
6DA. Tel: 01527 893392/07942
319432
eddiejones4@googlemail.com**

**B. New (2021), 6 Coleridge Gardens,
Cowplan, Waterlooville, Hants PO8 8LS.
Tel: 02392 645114**

**A. Penny (2021), Culross, Hadleigh Road,
Elmsett, Ipswich, Suffolk IP7 6ND.
Tel: 01473 658768
apenny@nwsfld.f9.co.uk**

**D. Porter (2021), 96 Pembroke Avenue, Luton,
Beds LU4 9BJ. Tel: 07710 435127/01582
847399 david.porter31@btopenworld.com**

**M. Rapley (2021) 3 New Acres,
Carnforth, LA5 9XD. Tel: 07788
161929 rapley47@outlook.com**

**D. L. Ryder (2021) The Bungalow, Hagley
Road, Rugeley, Staffs WS15 2AW. Tel:
01889 582563**

**J Sayer (2021) Hylands Dunmow Road,
Thaxted, Dunmow, Essex. Tel: 07816
393894 jayessex114537@aol.com**

**R. Smith (2021) 18 Alma Street,
Melbourne, Derby DE73 1GA. Tel:
01332 864581**

**ROAD RACE, DRAG AND SPRINT
COMMITTEE**

**CHAIRMAN – Dr. P. D. King (2022) (NTB) c/o
ACU Road Race Dept, ACU House, Wood
Street, Rugby, CV21 2YX. Tel: 01788
566400 paul.king@acu.org.uk**

**DEPUTY CHAIRMAN – S. Higgs MotorSport
Vision Centre, Brands Hatch Circuit,
Fawkham, Longfield, Kent DA3 8NG.
Tel: 01474 872331**

**Mrs J Shedden (appointed by AMRCO),
Knockhill Circuit by Dunfermline,
Fife KY12 9TF. Tel: 01383 723337
enquiries@knockhill.com**

**M. Dommert (2022) (NTB) British
Motorcycle Racing Club Limited Unit
D2, Seedbed Centre, Davidson Way,
Romford, Essex. RM7 0AZ. Tel: 01708
720305. Mob: 07970 963572
mikedommert@hotmail.com**

**M Jessup (2022) 54 Monks Road, Binley
Woods, Coventry, CV3 2BS. Tel: 02476
544463 mark.jessup@btinternet.com**

**I. McLeod (2020) 6 Raven Rd, Yoxall, Burton on
Trent, Staffs, DE13 8PY. Tel: 07860 694548
ian_mcleoad2@sky.com**

E. Nelson (2021) "Anvil House", Derby Road, Old Tupton, Chesterfield, Derbyshire S42 6LA. Tel: 01246 866537

Dr. J. Palmer Motorsport Vision Ltd, Brands Hatch, Fawkham, Longfield, Kent DA3 8NG. Tel: 01474 875202

Committee Secretary: Rowena Perks. Tel: 01788 566406 rowena@acu.org.uk

Assistant Road Race Secretary: Michelle Haynes. Tel: 01788 566406 michelle@acu.org.uk

TRACK RACING COMMITTEE

CHAIRMAN – A. Steele (2021) 22 Church Street, Billesden, Leicester LE7 9AE. Tel: 07889 862077

tandj22@btinternet.com

G Bemister (2021) 62 Church Park Road, Plymouth, Devon, PL6 7SA. Tel: 07929 886327 garethbemister@outlook.com

P. Hurry (2021) Greenway, Headcorn Road, Grafty Green, Maidstone, Kent ME17 2AN. paulhurry86@hotmail.com

S. Brace (2020) 33 Patricia Gardens, Bishops Stortford, Herts CM23 3QE scbrace@hotmail.com

S. Harvey (2022) Newlands, Drake Lane, Little Waltham, Chelmsford, Essex, CM3 3ND. Tel: 07802 654372 teamharveyhogg@googlemail.com

D. Staff (2021) 32 Jutland Crescent, Hunters Meadow, Andover, Hampshire SP10 4NB. Tel: 01264 358345 dickie.staff@outlook.com

Committee Secretary: Tracey Cossar. Tel: 01788 566402 tracey.cossar@acu.org.uk

MOTOCROSS COMMITTEE

CHAIRMAN – S. McCauley (2021) 1 Brecon Close, Wansbeck Manor, Ashington, Northumberland NE63 0HT. Tel: 07747 864384 steve.mx@aol.com

J. Blyth (2020) 21 Ashe Road, Lower Hacheston, Woodbridge, Suffolk IP13 0PD. Tel: 07971 139010 john.blyth@hotmail.com

A. Hay (2021) 27 Tizzick Close, Norwich, NR5 9HB. Tel: 01603 734700 andrew.hay10@icloud.com

T. Lightfoot (2022) [Tel:01788566400](mailto:tim@acu.org.uk)
tim@acu.org.uk

C. Warren (2020) 39 Walburton Way, Clanfield, Hampshire, PO8 0XP. Tel/ Fax: 01730 894241/07809 443132

wgconsultants@hotmail.co.uk

Committee Secretaries: Sonia Goggin. Tel: 01788 566404 sonia@acu.org.uk

Kirsty Telford. Tel: 01788 566408

kirsty@acu.org.uk

TRIALS AND ENDURO COMMITTEE

CHAIRMAN – J. Collins (2020) 52 Margam Road, Margam, Port Talbot, West Glamorgan SA13 2BW. Tel: 01639 882241 johncollinsemail@yahoo.co.uk

M. Bates (2022) Nant-yr-Wyn, Llanbister Road, Llandridod Wells, Powys LD1 5UP. Tel: 01547 550393

G. Lawley (2020) Crossing Cottage Long Lane, Craven Arms, Shropshire, SY7 8DU. Tel: 01588 672415

gordon.lawley1@btinternet.com

A. Rew (2020) Wolborough Barton, Newton Abbott, Devon TQ12 1EJ. Tel: 01626 365107 Mob: 07734 830021

wolborough@btconnect.com

M. Seward (2022) Windmill House, Sutton Road, Wigginton, York, YO32 2RA.

Tel: 07801 256757 mpsracing@gmail.com

P. Sparkes (2022) 9 Engine Common Lane, Yate, Bristol, BS37 7PX. Tel: 078367 06735 phil@wessexplant.com

M. Wren (2020) Levenside, Newby Bridge, Ulverston, Cumbria LA12 8LZ.

Tel: 01539 531082/07921 214661

mick.trials@gmail.com

TRIALS WORKING GROUP

Paul Nash ACU Eastern [nap148@aol.com](mailto:nash148@aol.com)

Michael Owen ACU Isle of Man
mostationgarage@gmail.com

Karen Southerood ACU South Midland
karensouthwood51@gmail.com

Andrew Walker ACU East Mids
andrewwalker1@sky.com

Paul Wright ACU East Yorks
paulwrightjoshani@msn.com

Committee Secretaries: Mary Kerr. Tel: 01788 566403 mary@acu.org.uk

Kathy Walton. Tel: 01788 566409

kathryn@acu.org.uk

Madalena Miguens. *Tel: 01788 566412*
 madalena@acu.org.uk

BENEVOLENT FUND ADMINISTRATIVE COMMITTEE

CHAIRMAN – R. Hanks 50 Lyndhurst Road, Erdington, Birmingham B24 8QS.
 royacu97@gmail.com

Mrs M. Carter JP (Treasurer) 10 Byeway, Guiseley, Leeds LS20 8JP. *Tel: 01943 878666*

mcarterhuntersgap@btinternet.com

Mrs W. Evans MBE 3 Mount View Terrace, Onchan, Isle of Man IM3 1AB.
Tel: 01624 621296/07624 433540

acubenfundiom@manx.net

Mrs L Francis *Tel: 0151 336 4940*
 lyn.francis18@gmail.com

Mr Eddie Nelson “Anvil House”, Derby Road, Old Tupton, Chesterfield, Derbyshire S42 6LA. *Tel: 01246 866537*

C. Pattison 6 Churchfields, Wincanton, Somerset BA9 9AJ. *Tel: 01963 33001*

Mr D. Porter 22 Belper Road, Luton, Beds, LU4 8RG. *Tel: 01582 651189*

david.porter31@btinternet.com

Trustees: Mrs M. Carter, Mrs W. Evans MBE, Mrs L Francis, R. Hanks, Mrs J. Macphee, C. Pattison.

Secretary: Debbie Walmsley. Tel: 01788 566419

dw@acu.org.uk

TECHNICAL PANEL

TECHNICAL CONSULTANT Road Race –

Dr. P. King c/o ACU Road Race Dept, ACU House, Wood Street, Rugby, CV21 2YX.
Tel: 01788 566400

paul.king@acu.org.uk

TECHNICAL CONSULTANT Off Road –

Mr A. Summers 101 Friar Park Road, Wednesbury, West Midlands WS10 0JR. *aws.30acu@outlook.com*

TECHNICAL CO-ORDINATOR – Mr E. Jones 18 Chapel Street, Astwood Bank, Redditch B96 6DA. *Tel: 01527 893392/07947 319432*

Mr S Brace 33 Patricia Gardens, Bishops Stortford, Herts, CM23 3QE. *Tel: 07749 666767 scbrace@hotmail.com*

Secretaries: Michelle Haynes. Tel: 01788 566405 michelle@acu.org.uk (Road Racing Technical matters)

Kirsty Telford. *Tel: 01788 566408*

kirsty@acu.org.uk (Off Road Technical matters)

ACU SUSTAINABILITY PANEL

CHAIRMAN – P. Gregory 9 The Green, Saltburn, Cleveland TS12 1NF. *Tel: 01287 625607*
 pgregory@ntlworld.com

(Members to be appointed by Sport Committees plus Specialist Representatives).

Secretary: Kirsty Telford. Tel: 01788 566408

kirsty@acu.org.uk

MEDICAL PANEL

CHAIRMAN: Mr R Hanks

Mr K Dwyer Dr B Winter

Chief Medical Advisor: Dr HRomer

Secretary: Debbie Walmsley. Tel: 01788 566419

dw@acu.org.uk

ACU EVENTS LTD DIRECTORS

CHAIRMAN – B. Higgins Sunnycote, Marytavy, Tavistock, Devon PL19 9QB. *Tel: 01822 810336/07793 494793*

brianhiggins424@gmail.com

J. Collins 52 Margam Road, Margam, Port Talbot, West Glamorgan SA13 2BW. *Tel: 01639 882241 Fax: 01639 773470*

johncollinsemail@yahoo.co.uk

R. Hanks 50 Lyndhurst Road, Erdington, Birmingham B24 8QS. *Tel: 0121 686 3799*
 royacu97@gmail.com

R. Humphrey 11 Shepherds Avenue, Earley, Nr. Reading, Berks RG6 1AY. *Tel: 07850 598886 royh.acu@btinternet.com*

Dr P D King c/o ACU Road Race Dept, ACU House, Wood Street, Rugby, CV21 2YX.
Tel: 01788 566400

paul.king@acu.org.uk

Company Secretary: Sonia Goggin. Tel: 01788 566404 sonia@acu.org.uk

ACU INSURANCE LTD DIRECTORS

B. Higgins Sunnycote, Marytavy, Tavistock, Devon PL19 9QB. *Tel: 01822 810336/07793 494793*

brianhiggins424@gmail.com

I Murphy Thie Roarbrae, 11 Sileau Curn Park, Kirk Michael, Isle of Man IM6 1EH.

Tel: 01624 878394 murf@manx.net

Mrs G. Brough

Mr G. Crease

SpEEDWAY CONTROL BUREAU

J Lawrence (Independent Chairman) 15
Wide Street, Hathern, Loughborough,
LE12 5JQ. Tel: 0777 8402467
jl15@btinternet.com

K Chapman Kings Lynn Speedway, Adrian
Flux Arena, Saddlebow Road, Kings
Lynn, Norfolk PE34 3AG. M: 07734
248833
B: 01553 771111 kc@norfolkareana.co.uk

P Hurry (ACU) Greenways, Headcorn
Road, Grafty Green, Maidstone,
Kent, ME17 2AN. Tel: 07712
667145
paulhurry86@hotmail.com

A Steele (ACU) 22 Church Street, Billesden,
Leicester, Leics LE7 9AE. Tel: 07889 862077
tandj22@btinternet.com

C Van Straaten (BSPA) 14 Hartland Road,
Tipton, DY4 8BQ. Tel: 07802 463339
cvs46@hotmail.com

Administrator: Neil Vacher. Tel: 01788 565603

Fax: 01788 552308

*SCB Secretary: Nikki Jamieson. Tel: 01788
565603 info@scvbg.co.uk*

MCRCB

Dr J Palmer (Chairman/AMRCO)

Mrs G Shedden (MRPC)

Dr P D King c/o ACU Road Race Dept, ACU
House, Wood Street, Rugby, CV21 2YX.
Tel: 01788 566400
paul.king@acu.org.uk

Auto-Cycle Union Limited structure

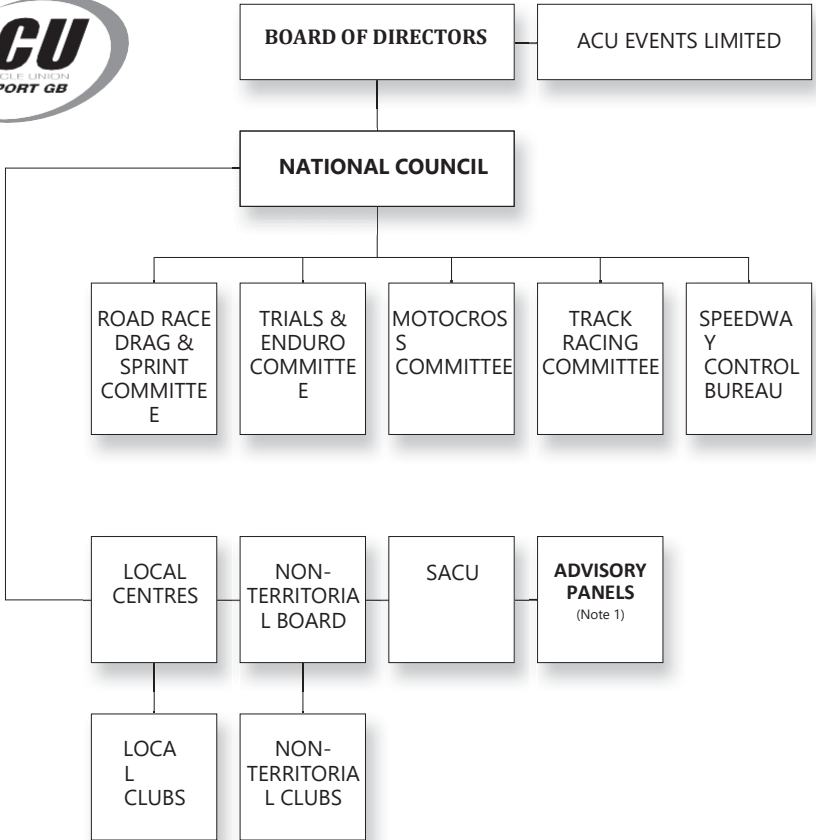

NOTE 1
Technical
Sustainable Event
Management Medical
International
Adjudicators

Who should I contact at the ACU?

Normal office hours are 09.00–17.00. Monday–Friday.
Outside these hours please leave an answer phone message.

GENERAL RECEPTION

Tel: + 44 (0) 1788 566400

Fax: + 44 (0) 1788 573585

admin@acu.org.uk

k Website: www.acu.org.uk

LICENSING ENQUIRIES

Tel: +44 (0) 1788 566417

Fax: +44 (0) 1788 552967

licence@acu.org.uk

General Secretary

Assistant to the General Secretary

Motocross & Competitions Secretary

Motocross Assistant, Off Road Technical Secretary and Sustainable Event Management Panel Secretary

Road Race Secretary

Road Race Assistant and

michelle@acu.org.uk Road Race Technical Secretary

Track Racing Secretary

tracey.cossar@acu.org.uk Trials & Enduro Secretary

mary@acu.org.uk

Trials & Enduro Secretary

Trials & Enduro Secretary

madalena@acu.org.uk PR & Marketing Officer

IOM TT Clerk of the Course/
Event Safety

Financial Controller

IT Manager

Training

ACU Benevolent Fund Secretary

Administration Assistant & GDPR POC Marie Devey 01788 566422 marie@acu.org.uk

Neil Doctor 01788 566434 neil@acu.org.uk

Debbie Walmsley 01788 566419 dw@acu.org.uk

Sonia Goggin 01788 566404 sonia@acu.org.uk

Kirsty Telford 01788 566408 kirsty@acu.org.uk

Rowena Perks 01788 566406 rowena@acu.org.uk

Michelle Haynes 01788 566405

Tracey Cossar 01788 566402

Mary Kerr 01788 566403

Kathy Walton 01788 566409 kathryn@acu.org.uk

Madalena Miguens 01788 566412

Richard Blyth 01788 566428 pr@acu.org.uk

Gary Thompson MBE BEM 01788 566414

gary@acu.org.uk

Jacky Lonsdale 01788 566411 jacky@acu.org.uk

Jillian Nash 01788 566407 jillian@acu.org.uk

Debbie Walmsley 01788 566419 dw@acu.org.uk

Debbie Walmsley 01788 566419 dw@acu.org.uk

ACU EVENTS LTD

General Secretary

Sonia Goggin

01788 566404

sonia@acu.org.uk

NON-TERRITORIAL BOARD

President:

Mrs. M Mellish, 4 Douglas Avenue, Harold Wood, Romford, Essex RM3 0UT. Tel: 01708 342684 mmmellish@aol.com

Vice President:

Mr Eddie Bellars, 12 Rosehill Park, Emmer Green, Reading, Berks RG4 8XE. Tel: 0118 947 0837. Mob: 07887 990617.

bellars@virginmedia.com

Chairman:

Lt. Col. Mike Tizard, 18 Sherfield, Winterbourne, Dauntsey, Salisbury, Wiltshire, SP4 6 HF. Tel: 01980 610425/07767 756167

mike.tizard@btinternet.com

Vice Chairman:

Mr. I Botham, Allen House, Wetmore Road, Burton on Trent, Staffordshire, DE14 1TR. Tel: 01283 540557 ianbotham@vmcc.net

General Secretary:

Mrs Sally Russell, Houndshill Cottage, Banbury Road, Ettington, Stratford upon Avon, Warks, CV37 7 NS. Tel: 01789 740866

russell.sally4@gmail.com

NON-TERRITORIAL CLUBS

0500 Army Motorcycling Association (BAMA)

Lt Col Mike Tizard, 18 Sherfield, Winterbourne, Dauntsey, Salisbury, Wiltshire SP4 6HF. Tel: 01980 610425/07767 756167

mike.tizard@btinternet.com

E, T, HH, SCE, RR rr

0505 Boundless

Joselyn Williams, c/o Member Communities, Britannia House, 21 Station Street, Brighton BN1 4DE. Tel: 0845 3457444 Fax: 01273 744645

joselyn.williams@boundless.co.uk
www.boundless.co.uk

0502 British Motor Cycle Racing Club Ltd

Ms Tracey Ringrow, BMCRC, Unit D2, Seedbed Centre, Davidson Way, Romford, Essex RM7 0AZ. Tel: 01708

720305/01708 509161 Fax: 01708

720235

bemseeoffice@gmail.com

www.bemsee.net

RR, rr

0503 British Motorcycle Racing Club

Marshals Association

Ms Tracey Ringrow, BMCRC, Unit D2, Seedbed Centre, Davidson Way, Romford, Essex RM7 0AZ. Tel: 01708

720305/01708 509161 Fax: 01708 720235

bemseeoffice@gmail.com

www.bemsee.net

RR, rr

0504 British Scooter Sport Organisation

Mr Chris Geyton, 16 Victoria Road, Bridgnorth, WV16 4LA. Tel: 07973 358456 www.scooterracing.org.uk
SCR, SC, SCT, ST, SR

0377 CJSC

Mrs Julia Kirk, 12 Milne Close, Bircotes, Doncaster DN11 8AP. Tel: 07583 254834

cjsc1motocrossclub@gmail.com

mx

0764 Classic & Modern 50 Racing Club

Mr Sydney Dore, 156 Cozens Road, Ware, Hertfordshire, RG12 7HP. Tel: 07901 558039 syddore@hotmail.com

RR, rr

0506 Classic Racing Motorcycle Club Ltd

Mrs Sally Russell, Houndshill Cottage, Banbury Road, Ettington, Stratford upon Avon, Warwickshire CV37 7NS.

Tel: 01789 740866

sally.russell@crmc.co.uk www.crmc.co.uk

RR

0507 Clubmans Racing MCC

Dr P King, c/o ACU Road Race Dept, ACU House, Wood Street, Rugby, CV21 2YX. Tel: 01788 566400

paul.king@acu.org.uk

RR, MX

0598 Ducati Sporting Club

Mr Chris Bushell, 103 Willow Park, Otford, Sevenoaks, Kent, TN14 5NF. Tel: 01959 522249

chris.bushell@ducatisportingclub.com

www.ducatisportingclub.com

RR

0742 Ducati Owners Club GB

Christopher Holland, 1 Walkington Drive, Market Weighton. Tel: 07766 001075

secretary@docgb.net

RR

0576 EBTC BikeTrial Our Sport

Mr Stuart Matthews, 40 Thanet Road,
Bexley, Kent DA5 1AP. Tel: 07940
725098 (day); 01322 556164 (eve)
stuartmatthewsferrari@yahoo.co.uk
BT, bt

0810 East Anglian Schoolboy Scrambling Club

Mrs. Jean Ingram, 18 Austral Way,
Althorpe, CM3 6UP. Tel: 01621 740795
07748 666066
jeaningram@btinternet.com
MX mx

0808 FBPMC (Kent)

T Fleming, Major Crime Folkestone
Police Bouverie Road, West Folkestone,
CT20 2SG. Tel: 01303 289600/07870
252290
58315@kent.pnn.police.uk

0509 Formula Sidecar Racing Association

Pat Hamblin, 4 Tivey Way,
Melbourne, Derbyshire, DE73 8JS.
Tel: 01332 805535/07971 821850
pat.fsra@talktalk.net www.fsra.org.uk
RR

0836 Freetech Racing Club

Ian Denny, 13, Newbolt Close,
Thatcham, Berkshire RG18 3UQ. Tel:
07759 315961
freetechracingclub@yahoo.com
RR, S, HC

0852 GP Originals

Mrs. Sally Russell, Houndshill Cottage,
Banbury Road, Ettington, Stratford upon
Avon, Warks. CV37 7NS. Tel: 01789
740866 russell.sally4@gmail.com
www.gporiginals.co.uk
RR

0510 GRASA

Mrs Di Wain, 104 Purbrook Way,
Leigh Park, Havant, Hampshire PO9
3SB. Tel/Fax: 02392 644061/07881
818089
diwain@ntlworld.com www.grasa.co.uk
GT

0627 Greeves Riders Association

Kevin Scudder, 37, Main Street,
Caldecott, Rutland LE16 8RS Tel: 07465
913613
01536 771890 kscudder1@alive.com
T, Social

0806 Historic Racing Fifty MCC

Mr John Stuart Harrison, 109
Kingston Road, Earlsdon, Coventry,
CV5 6LQ. Tel: 07534 32198

0282 KRC

G Marchant, The Cottage High
Street, Leigh, Tonbridge,
TN11 8RH. Tel/Fax: 01732
838500
gjm racing@hotmail.co
m
www.krcendurance.co.

*uk RR***0780 The Lansdowne Classic Series Ltd Mrs.**

Sally Russell, Houndshill Cottage,
Banbury Road, Ettington, Stratford
upon Avon, Warks. CV37 7NS. Tel:
01789 740866
russell.sally4@gmail.com
www.lansdowneclassic.co.uk
RR

0590 London Douglas Motorcycle Club Ltd

Mr Roy Staunton, Highbanks
12A Kings Orchard,
Basingstoke, RG23 7AX. Tel:
01256 780819
secretary@douglasmcc.co.uk
RAL

0609 Mercian Dirt Rider

Mrs Judith Belcher, c/o Bikestation
UK Ltd, 76a Station Road, Yate,
Bristol, BS37 4PH. Tel: 07500
831159
mail@merciandirtriders.com

0585 MR Thumpercross Club

Mr Adam Hooper, c/o Martins
Rubber Co Ltd, 28-36
Orchard Place, Southampton
SO14 3PE.
Tel: 02380 226330 Fax: 02380 631577
mrthumpercross@thumpercross.com
www.thumpercross.com
MX

0511 Morgan Three Wheeler Club Ltd Mr

Anthony Pearson, 60 Upper Car
Lane, Calverley, Leeds, LS28 5QE.
Tel: 01132 578710 compsec@mtwc.co.uk
www.mtwc.co.uk
RR, S, HC, T, LDT

0513 The Motor Cycling Club Ltd

Mr Simon Woodall, Ballards Place,
Eardiston, Tenbury Wells, WR15
8JR. Tel: 01584 881348 simon.
woodall@themotorcyclingclub.org.uk
www.themotorcyclingclub.org.uk
T, LDT

0514 Motorcycle Club of Wales

Bryan Puckett Tel: 07866 354809
bryanpuckett.acuws@gmail.com

0635 MWTRA

Vic Madeley, Greenfields, Kerry,
Nr Newtown, Powys, SY16 4LH.
Tel: 01686 670596 Fax: 01686
670354
vic@mwtra.co.uk

0515 National Association of Supertwins

Mrs Yvonne Mott, 17 Maidenhead
Court Park, Maidenhead, Berks, SL6
8HN. Tel: 07785 926957/01628
630745
ymott@its.jnj.com
www.supertwins.co.uk
DR

0516 National Hill Climb Association

Mr Peter Isaac, 205A Berrrow Road,
Burnham-on-Sea, Somerset TA8 2JG.
Tel: 01278 786377
pgisaac@tiscali.co.uk
www.nhca.co.uk
HC, hc

0517 National Sprint Association

Dave Massam, 1 Valley View, Farway,
Colyton, Devon, EX24 6EE. Tel: 01297
552396
S, s

0518 New Era MCC

Mr Phil Tomlin, 25 Rusper Road,
Dagenham, Essex RM9 4NT. Tel:
07711 822594
phillip.tomlin@btinternet.com *RR, rr,
PB, pb, SM, sm*

0519 N G Road Racing Club

Paul Buckland, 15 Edgeworth,
Miserden Road, Cheltenham GL51
6BW. Tel: 07785 803560
paul.buckland56@btinternet.com
www.ngroadracing.org
RR, rr

0805 Norton Owners Club

Barry Stickland, 110 Reading Road,
Finchampstead, Wokingham,
Berkshire, RG40 4RA. Tel: 0118 973
0589
noc@waitrose.com

0520 RAF Motorsports Association

Ian Ridley, 31 Harmston Park
Avenue, Harmston, Lincs, LN5 9GF.
Tel: 07703 592674
ian.ridley@me.com

**0825 Royal Navy Royal Marines Motorsport
Association (RNRMMSA)**

Brian Fuidge, Hamworthy Barracks,
Hamworthy, Poole, BH15 4NQ
rnrmrmt@hotmail.com

0521 Santa Pod Racers Club

Mr Ian Marshall, SPRC, PO
Box 12, Rushden, Northants
NN10 0ZU. Tel: 01933
313625
irmarshall@btconnect.com
www.eurodragster.com/spr
c *DR*

**0522 Sidecar Motocross Association of Great
Britain**

Polly Chewter, 4 Park Rise, Petworth,
West Sussex, GU28 0HU. Tel: 07740
806201
polly_chewter@hotmail.co.uk
MX

0865 The Vespa Club of Britain Ltd.

Owen Evans. Tel: 07930
328835
gensec@vespaclub.uk
T, Social

0524 Trail Bike Enduro Club (TBEC)

Mrs Belinda Jarman, 9 Chestnut
Drive, Thorney, Peterborough, PE6
0QR secretary@tbec.co.uk
www.tbec.co.uk *HH*

0525 Triumph Owners MCC

(Club representative) Mrs Margaret
Mellish, 4 Douglas Avenue,
Harold Wood, Romford, Essex
RM3 0UT. Tel/Fax: 01708
342684
mmmellish@aol.com
RR, RAL, Social

0518 Trail Riders Fellowship (TRF)

Mario Costa-Sa or Chris
Barrable, acu@trf.org.uk
www.trf.org.uk *RR, RAL, Social*

0572 TT Supporters Club

Mrs Rose Hanks, 50 Lyndhurst
Road, Erdington, Birmingham B24
8QS. Tel: 0121 3731035/0121
6863799
royacu97@gmail.com
Social

**0848 TwoFourThree (243) Road Racing
Association**

Shaun Dalton, Weaponess Farm,
Olivers Mount, Scarborough, W
Yorks. YO11 2YW. Tel: 07895
086860
243rra@gmail.com
RR, S, HC, T

0654 Veteran Vespa Club

Robert Dixon-Box, 109 Hill
View Road, Bournemouth,
Dorset, BH10 5BL. Tel: 07872
970075
generalsecretaryvvc@gmail.
com
www.veteranvespaclub.com
Social

0527 Vintage Motor Cycle Club Ltd Mr

I Botham, Gen Manager Allen
House, Wetmore Road, Burton
onTrent, Staffordshire DE14
1TR.
Tel: 01283 540557 Fax: 01283 510547
ianbotham@vmcc.net
RR, S, D, SRR, GT, T, RAL

0529 Welsh Trail Riders Association

Mr Steve Williams, 2 Elm Lodge,
Woodside Hamlet, Ham Manor Park,
Llantwit Major, CF61 1BN. Tel: 07445
868463 viper.williams1@gmail.com
www.wtra.co.uk
E

0845 1946 Marshal Association

Mr Shaun Dalton, Weaponess Farm,
Olivers Mount, Scarborough, North
Yorkshire, YO11 2YW. Tel: 07895
086860 oneninefoursix@hotmail.com
RR, S, HC, T

THE SpORTS COUNCILS**UK Sport**

40 Bernard Street, London WC1N 1ST.
Tel: 0207 211 5100 Fax: 0207 211
5246

Sport England

3rd Floor Victoria House, Bloomsbury
Square, London WC1B 4SE. Tel: 0207
2731551 Fax: 0207 383 5740

Sport Scotland

Caledonia House, South Gyle,
Edinburgh EH12 9DQ. Tel: 0131 317
7200 Fax: 0131
317 7202

Sportswales

Sophia Gardens, Cardiff CF11 9SW.
Tel: 0845 0450904 Fax: 0845
8460014

RECOGNISED pROMOTERS**ACU Events Limited**

ACU House, Wood Street, Rugby,
Warwickshire CV21 2YX. Tel: 01788
56640 sonia@acu.org.uk

Brackley Festival of Motorcycling Club

Roger Charlesworth, Peartree House,
Glovers Lane, Middleton Cheney,
Banbury OX17 2NU. Tel: 01295
710159

07789 867324 trc1@rocketmail.com

Club Thundersport Limited

Dave Stewart, Unit 4, Knowle Hill
Farm, Ingleby Lane, Ticknall DE73
7JQ. Tel: 01509 809530/07738
355186
jamiestewart9@googlemail.com

CORE Off Road Events

9 Riviera Terrace, Dawlish,
Devon, EX7 0AE. Tel: 07971
051509

simon@coreoffroadevents.co.uk

David Knight Racing Ltd

The Pines, Ballaugh, Isle of Man IM7 5AS
07624 498498
knighter101@icloud.com

Dirtbike Action Limited

John Kerwin, Wayside, South Stainley,
Harrogate, HG3 3LT. Tel: 07557
665647 krwnmt@aol.com

Dorset Enduro

Craig Redmond, 13
Encombe Road, Wareham,
BH20 4PS
dorsetenduro@hotmail.co
m

Edge OffRoad Events

Sonya Jarvis
sonya@edgeoffroad.events. Tel:
07557 447084

Fab-Racing

Tel: 01273 782828 mail@fab-racing.co.uk

Fast Eddy Racing Ltd

c/o Chris Parkes, Unit 2, Rolling Mill
Lane, Norton Canes, Staffs, WS11
9UH. Tel: 01543 37070/07889
924560
fasteddyracing@hotmail.co.uk

G2F Media

3 The Old Court House, Tenterden
Street, Bury BL9 0AL. Tel: 0161 763
6660 info@g2fmedia.com

George Wilby Racing

Stephen Tyrrell, Ratty's Retreat,
Herringfleet Road, St. Olaves, Norfolk
NR31 9HW. Tel: 01493
488648/07799 168747

Hit the Dirt

Dave Barkshire, 1 Chestnut Court, Rackheath Industrial Estate, Norwich, Norfolk NR13 6LH. Tel: 01603 722800 davebarkshire@btconnect.com

Inch Perfect Trials Ltd

New Hey Barn, Dunsop Road, Whitewell Nr Clitheroe, Lancs BB7 3AU. Tel: 01200 448130 sales@inchperfecttrials.co.uk

Kieraden Park

North Moor Lane, Scunthorpe, DN17 3PS. Tel: 07789 633794 info@kieradenpark.co.uk

Lydden Hill Motorsports Club

Hannah Rynston, Lydden Hill Race Circuit, Wootton, Canterbury, CT4 6ET. Tel: 01304 830557 lymc@lyddenhill.co.uk

MotorSport Vision Racing (MSVR)

Motorsport Vision Centre, Brands Hatch, Fawkham, Longfield, Kent DA3 8NG. Tel: 01474 875296 bsb@msvracing.co.uk www.msvracing.com/bikes/marshalling/

MWTRA Promoters

Greenfields, Kerry, Nr Newtown, Powys SY16 4LH. Tel/Fax: 01686 670596 vic@mwtra.co.uk

No Limits Racing

Black Horse Barns, Fancott, Toddington, LU5 6HT. Tel: 01525 877087 nlr@nolimitstrackdays.com

Non Stop Trials MCC

Quad Challenge, Capel Hendre SA18 3RH Peter Flowers. Tel: 01269 839264 peter@quadchallenge.co.uk

Nora-Mx

NoraSport Supermoto Ltd, 20 Eydon Drive NN17 5FB. Tel: 07590 832058 info@norsport.co.uk

Oset Bike Ltd

Units 5-6 Highfield Business Park, Sidney Little Road, St Leonards On Sea, TN38 9UB simon-armstrong@osetbikes.com

Rally Moto Ltd

Suite 1A, 70 Copt Elm Road, Cheltenham, GL53 8AW. Tel: 07703 924448 robert@rallymoto.co.uk

Raw Enduro

Wayne Braybrook, West Yorkshire, BD21 5PU. Tel: 07802 572023 wayne@rawenduro.co.uk

RHL Activities Ltd

The Bryn Garage, Penpergwm, Abergavenny, South Wales, NP7 9AT. Tel: 01873 840640 info@rhlactivities.com

Saintswell Events

Adam Rees, Penbrycennau Farm, Abbeycwmhir, Llandrindod Wells, Powys, LD1 6PT adam_mark_rees@hotmail.com

Sherrard Classic Vehicle Events Ltd

Ian Sherrard, Black Bull House, 353-355 Station Road, Bamber Bridge, Preston, PR5 6EE. Tel: 07836 331324 info@leightonhallmotorcyclehillclimb.co.uk

Speed McQueen Events Ltd

Fatcat Moto Parc, Holmeward Lane, Armthorpe, Doncaster, DN3 3EH martin@fatcatmotoparc.com

Straightliners Ltd

5 Carr Street, Brighouse, West Yorkshire HD6 4AZ. Tel: 01484 710850/07971 172210 trevor@straightliners.co.uk

The British Superbike School

Mike Abbott mexec@live.co.uk

Trydan Off Road Centre

Coedcwm, Isaf, Cenarth, Newcastle Emlyn, Ceredigion SA38 9JT. Tel: 07870 904591 steve@trydanoffroad.com

Two Wheels Events

Unit 1, Featherby Place, Off High Street, Lincoln LN5 8BW. Tel: 07976 696773 stuartdrummond@live.co.uk

UK Timing Association

5 Carr Street, Brighouse, West Yorkshire HD6 4AZ. Tel: 07971 172210/01484 710850 trevor@straightliners.co.uk

West Midland Motocross MX Promotions

Thomas Arnold, 114 Highfield Road, Tipton DY4 0QR. Tel: 07759 891209 tomarnold@live.co.uk

0851 X Bladez Events

Dave Willet info@2strokefestival.com. Tel: 07789 816382

Yarley Moto Park

58-60 Bristol Hill, Bristol, BS4 5AB. Tel: 01179 714873 yarleymotopark@gmail.com

RECOGNISED ASSOCIATIONS

0565 British Schoolboy Motorcycle Association (BSMA)

Tracey O'Connor, The Saturn Centre, Spring Road, Ettingshall, Wolverhampton, WV4 6JX. Tel: 07436 563264 traceyoconnor.bsma@live.com

0847 California Superbike School Steve Leitch, 2280 Silverstone Park, Silverstone Circuit, Silverstone, Northants, NN12 8GX. Tel: 01327 855553 steve@superbikeschool.co.uk

Isle of Man Scrutineers Association
Brenda Rothwell, 8 Mournie View, Peel, Isle of Man, IM5 1UJ. Tel: 01624 610174
rothwellb@outlook.com

0847 Superbike Ltd
Steve Leitch, 2280 Silverston Park, Silverstone Circuit, Silverston, Northants, NN12 8GX. Tel: 01327 855553
steve@superbikeschool.co.uk

0555 Y.M.S.A. Ltd
Christine Heathcote, PO Box 735, Chesterfield, Derbyshire, S43 9DT. Tel: 07595 701470
christine@ymsaltd.co.uk

0566 Welsh Motorcycle Federation
Bryan Puckett. Tel: 07866 354809
bryanpuckett.acuws@gmail.com

USEFUL ADDRESSES

British Speedway Promoters Association (BSPA)
BSPA Office, ACU House, Wood Street, Rugby, Warwickshire CV21 2YX. Tel: 01788 560648 Fax: 01788 546785
office@britishspeedway.plus.com

Isle of Man Motorsport Team
Isle of Man Tourism, Department of Economic Development, Isle of Man Government, St Georges Court, Upper Church Street, Isle of Man IM1 1EX

Isle of Man TT Marshals Association Ltd
Isle of Man TT Marshals Office, Douglas, Isle of Man IM2 6DA. Tel/Fax: 01624 618191 info@iomttma.com

Lockton MIS Motorsport
10 South Parade, Leeds, LS1 5QS. Tel: 0113 389 3664
neil@mismotorsport.com

MCUI
Mr Andrew Campbell, 24 Ballyminstragh Road, Killinchy, Co. Down, Northern Ireland BT23 6RE. Tel: 0044 28975 41716
secmui@ireland.com

MCRCB
c/o Brands Hatch Circuit, Fawkham, Longfield, Kent, DA3 8NG. Tel: 01474 875296

Motorcycle Industry Association Ltd
1 Rye Hill Office Park, Birmingham Road, Allesley, Coventry CV5 9AB

MSA
Motor Sports House, Riverside Park, Colnbrook, Slough SL3 0HG. Tel: 01753 765000 Fax: 01753 682938
www.msauk.org

Racesafe Marshals Association
Motorsport Vision Centre, Brands Hatch, Fawkham, Longfield, Kent DA3 8NG. Tel: 01474 872331 Fax: 01474 874766 bsb@msvracing.co.uk
www.msvracing.com/bikes/marshalling/

Speedway Control Bureau
ACU House, Wood Street, Rugby, Warwickshire CV21 2YX. Tel: 01788 565603 Fax: 01788 552308
office@scbureau.plus.com

The Trail Riders Fellowship
P.O. Box 196, Derby DE1 9EY.

TT Riders Association
Frances Thorp, Mountain View, Glen Maye, Isle of Man IM5 3BJ. Tel/Fax: 01624 843695

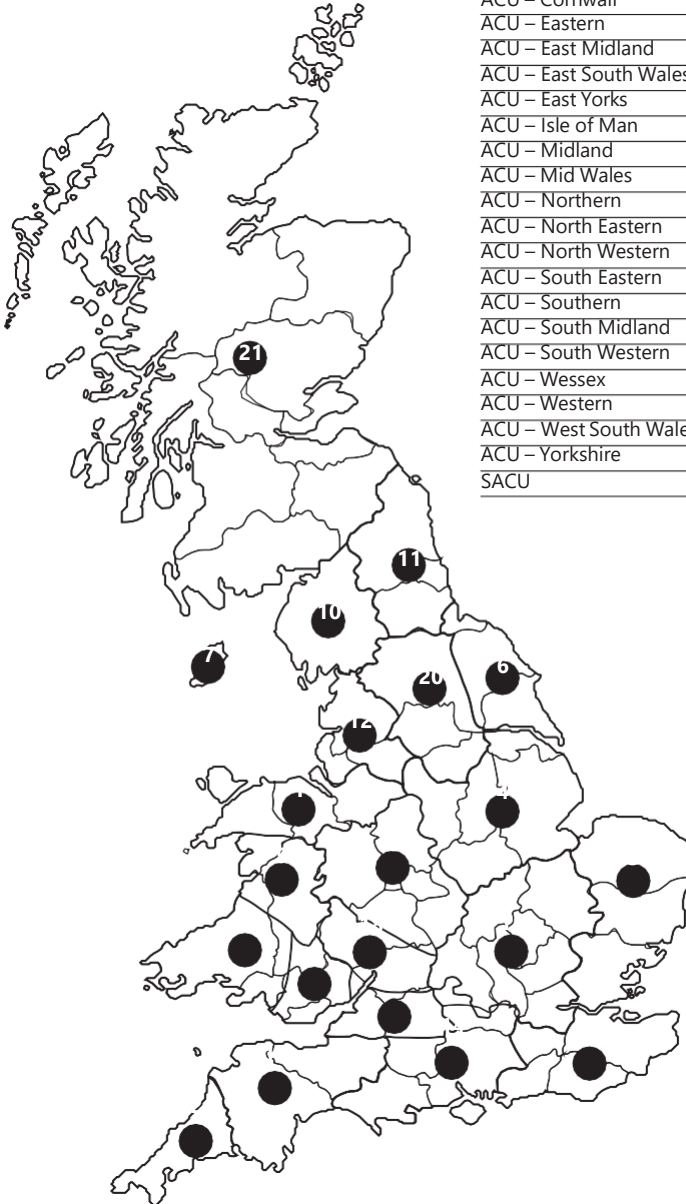

ACU – Cheshire & North Wales	1
ACU – Cornwall	2
ACU – Eastern	3
ACU – East Midland	4
ACU – East South Wales	5
ACU – East Yorks	6
ACU – Isle of Man	7
ACU – Midland	8
ACU – Mid Wales	9
ACU – Northern	10
ACU – North Eastern	11
ACU – North Western	12
ACU – South Eastern	13
ACU – Southern	14
ACU – South Midland	15
ACU – South Western	16
ACU – Wessex	17
ACU – Western	18
ACU – West South Wales	19
ACU – Yorkshire	20
SACU	21

Under each Club listed there is a key to the activities they offer, as follows:

	Adult <i>shown in caps</i>	Youth <i>shown in lower case</i>
Road Racing	RR	rr
Pocket Bike	PB	pb
Sprint	S	s
Drag Racing	DR	dr
Hill Climb	HC	hc
Supermoto	SM	sm
Motocross	MX	mx
Quad Motocross	QMX	
Supercross/Arenacross	AC	ac
Beachcross	BC	
Moto Ball	MB	
Grass Track Racing	GT	gt
Sand Racing	SR	sr
Quad Grass Track	QGT	
Short Track	ST	
Trial	T	t
Arena Trial	AT	at
Long Distance Trial	LDT	
Quad Trial	QT	qt
Bike Trials	BT	bt
Enduro	E	
Short Course Enduro	SCE	
Hare & Hounds	HH	
Road Rallies	RAL	
Social	Social	
Scooter Racing	SCR	scr

1 ACU – CHESHIRE & NORTH WALES

Area Cheshire (excluding those areas of the Halton and Warrington Districts situated north of the estuary of the River Mersey and north of the Manchester Ship Canal). Those areas of the Trafford, Manchester, Stockport and Tameside Districts of Greater Manchester situated south of the Rivers Mersey and Tame; the Wirral District of Merseyside, Wrexham/Powys/Wrexham boundaries through Maentwrog to the Meirionnydd District Boundary, the Newcastle-under-Lyme and Stoke on Trent Districts of Staffordshire.

Secretary

Mr Nick Bird, 15 Heol Offa, Tanyfron, Wrexham LL11 5TN. Tel: 07565 992886/01978 421490
cnw.secretary@gmail.com

Permit Secretary & Police Liaison Officer

Mr Paul Atkinson paulmatkin@f2s.com
Trials Recorder

Mr R. Dorricott, 1 Oaklands, Guilden Sutton, Chester CH3 7HE. Tel: 01244 300593 trialsrecorder@uwclub.net

Benevolent Fund Officer

Mrs L Francis. Tel: 077537 42911
lyn.francis18@gmail.com

0001 Cheshire Grass Track Club

Mrs Mae Winterton
maewinterton@aol.com
GT

0003 Cheshire MCRRCLtd

Mr Paul Minshall, 3 Southfield Road, Little Sutton, Cheshire CH66 1PL. Tel: 0151 339 8810 paul3south@gmail.com
www.motorcyclenet.co.uk
RR, SCR

0004 Cheshire North West Schoolboys SC

Helen Reid, 35 Sudbury Drive, Heald Green, Cheadle, Cheshire, SK8 3BT.
Tel: 07926 080672 nolegs18@outlook.com
MX, mx

0005 Cheshire Youth Trials Club

Miss Nerys Jones, 3 Lon Alun, Denbigh, Denbighshire, LL16 5YB. Tel: 01745 813392. nerys_12@hotmail.co.uk
T, t

0006 Colwyn MCC

Mr Graham Taylor, 12 Sunningdale Drive, Penrhyn Bay, Llandudno, Conwy LL30 3EG. Tel: 01492 549318/07721 400481 grahamjtaylor1958@gmail.com
www.colwynmotorclub.org.uk
T, t

0007 Congleton & DMC

Mr Martin Beech, 18 Springfield Drive, Congleton, Cheshire CW12 1HX. Tel/Fax: 01260 273068
mail@ebeechjoinery.co.uk
T

0008 Conwy & DMCC

Lisa McNulty
mcnullisv@aol.com
www.conwymotorcycleclub.org.uk
Social

0009 Crewe & South Cheshire MC Mrs

Yvonne Heeson, 7 Greenway,
Coppenhall, Crewe, Cheshire
CW1 4JN. Tel: 01270 583593
yvonne@tonfanauroadracing.co.uk
www.tonfanauroadracing.co.uk
RR, rr

0010 Denbigh & Mold Trials Club Ltd

Mrs Alison Mackrell, 10 Imperial
Terrace, Coronation Road, New
Broughton, Wrexham, LL11 6YB. Tel:
01978
758642 alison.tofield@hotmail.co.uk
www.denbighandmoldtrials.co.uk
T, t

0012 Frodsham & DMCC

Joanne Mackman, c/o 2 Machs
Motorcycles, Unit 64 Cosgrove
Business Park, Daisy Bank Lane,
Anderston, Northwich, CW9 6FY. Tel:
07958
81323 ian@2machsmotorcycles.com
www.frodshamtrials.org
T, t

0841 Helsby Grasstrack Club

Rachel Cox, 2 Holly Bank Road,
Runcorn, Cheshire, WA7 2AW. Tel:
07949 589923
rachelтетley@yahoo.co.uk

0013 Llangollen & DMCC

Mrs Sharon Hurdsmen, 30 Telford
Drive, Chirk, Wrexham LL11 5AJ. Tel:
01691 772406.
sharon.hurdsmen@uwclub.net
www.ldmcc.co.uk
T, t

0014 Macclesfield Trials Club Ltd

Mr Mark Cook
secretarymacctrails@mail.com. Tel:
07412
326455
T, t

0015 Manchester 17 MCC Ltd

Mr Henry Rosenthal. Tel:
07801 065331
henry@renthal.com
www.manchester17.org.uk
T, t, E, HH

0016 Manchester Eagle MC

Mr David Dolman, 12 Goldsworthy
Road, Flixton, Manchester M41 8TX.
Tel: 0161 748 3244
Social

0017 Nantwich & DMC

Chris Berisford, 38 Wybunbury
Road, Willaston, Nantwich,
Cheshire, CW5 7JE. Tel: 01270
652429/07748 234357
chris.berisford@sky.com
RR, S

0019 Oswestry & DMC

Mr Roger Smith, 25 Yew Tree
Avenue, Whittington, Oswestry,
Shropshire SY11 4BA. Tel: 01691
659533
roger.w.smith@btinternet.com
T, t

0021 South Liverpool MC

Mr Tom Leah, 28 Coach Road,
Bickerstaffe, Ormskirk, Lancashire, L39
0EU. Tel: 01695 7333930/07933
374009
tomleah@talktalk.net
S, T

0023 Whitchurch MCC

John Higham, 24 Cudworth
Road, Blackley, Manchester, M9
8PE. Tel: 0161 7208009/07587
082070
shaggy24@sky.com
GT, gt

0024 Winsford & DMC

Mr Mark Atkinson, 8 Harvest Close,
Moulton, Cheshire, CW9 8PX. Tel: 07827
835836. winsforddmc@outlook.com
T, t

0025 Wirral Hundred MC

Peter Thompson, 4 Blackdown Close,
Ellesmere Port, CH66 4YE. Tel: 0151 348
1139 deltaw100@gmail.com
RR, rr

0027 Wrexham MC

Lee Booth, 10 Ffordd y Gaer, Bradley,
Wrexham, LL11 4BW. Tel: 01978
752653
01978 752902 Mobile: 07725 040360
www.wrexhamtrials.com
T, t

2 ACU – CORNWALL

Area Cornwall.

President

Melroy

Youlton

Chairman

Mr John Young, 1 Bodieve Farm Cottages,
Wadebridge PL27 6EG. Tel: 01208
816716/07890 718820

flyingchef@thegranarywadebridge.co.uk

Treasurer

Mr Richard Jones, 16 Foxdown,

Wadebridge PL27 6BD. Tel: 01208 813745
e16foxdown@hotmail.com

Permit Secretary

Mrs Heather Wilcox. Tel: 01637 871033
heatherwilcox777@yahoo.co.uk

Trials Recorder

Mr R. Parkyn, Mandalay Old Pound, Nanpean,
St. Austell, Cornwall PL26 7XS. Tel: 01726
824665

Grass Track Recorder

Tracey Bree 01726 828008

Benevolent Fund Officer

Chris Tyrrell, Kangal Farm, Criggan, Bugle, St
Austell, PL26 8QX. Tel: 01726 890404/07970
281545 christ6996@hotmail.com

ACU Point of Contact

Mrs Elaine Jones, 16 Foxdown,
Wadebridge PL27 6BD. Tel: 01208
813745 e16foxdown@hotmail.com

0031 Camborne & Redruth DMC & LCC

Lynn Roberts, c/o My Motors,
East End, Redruth TR15 2EJ. Tel:
01209 214114
crmcltd@hotmail.co.uk
www.camborneandredruthmotorclub.com

MX, T, HH

0032 Camel Vale MCC

Mrs Elaine Jones, 16 Foxdown,
Wadebridge, Cornwall PL27
6BD. Tel: 01208 813745
e16foxdown@hotmail.com
www.camel-
valemcc.net
T, t, LDT, E, HH

0033 Cornwall & Devon Motocross Club

Robert Jago, 27 Churchtown Meadows,
St Stephen, Cornwall, PL26 7NF. Tel:
07790 449503
robert.jago@cmfactors.uk
www.cornwallmxclub.co.uk
MX, QMX, SCMx, Social

0034 Cornwall Solo Grass Track Club Ltd

Mrs Ann Johns, Homestead, Buller Hill,
Redruth, Cornwall TS16 6SR. Tel:
01209 217454 www.csgtc.co.uk
GT, gt

0537 Mid Cornwall Premier Motorcycle Club

Mr Mark Courtney, 88a
Daniels Lane, Holmbush, St
Austell, PL25 3HT. Tel: 07810
885174
mark.courtney26@gmail.com
www.mcpmcc.com
GT

0036 Pendennis MC & LCC Ltd

Mr Matt Dunstan
pendennismcc@outlook.com
www.pendennismotorcycleclub.co.uk
MX, BC, QMX, LST, BT, E, SCE, HH, Social

0038 West Cornwall MC Ltd

Mike Roberts Tel: 078106 32880
www.westcornwallmotorclub.com
m HC, T, t, HH

3 ACU – EASTERN

*Area Norfolk, Suffolk, Essex and that
area of Greater London situated north
of the River Thames and east of the
River Lea. Secretary*

Mrs L. Ralph, 23 Tymmes Place, Hasketon,
Ipswich, Suffolk IP13 6JD. Tel: 01394
389330/07857 601753

lynralph@outlook.com **Chairman**

Mr R G Hearn (Jack), 25 Quinton Road,
Needham Market, Suffolk IP6 8BP. Tel/
Fax: 01449 721042

jackhverah7@gmail.com **President**

Mr A. E. Penny, Culross, Hadleigh Road,
Elmsett, Ipswich, Suffolk IP7 6ND. Tel:
01473 658768 apenny@nwsstd.f9.co.uk

Treasurer

Mr A. J. Hay, 27 Tizzick Close,
Norwich NR5 9HB. Tel: 01603
734700
andrew.hay10@icloud.com

Permit Secretary

Mr P. Armes, 10 Tremaine Close, Hellesdon,
Norwich NR6 5EL. Tel: 01603 487061
permits@easternacu.org

Motocross Recorder

Mr C Ralph, 23 Tymmes Place,
Hasketon, Woodbridge, Suffolk IP13
6JD. Tel: 01394 389330
cralph333@live.co.uk

Track Racing Recorder

Mr J. Sayer, 'Hylands', Dunmow Road,
Thaxted, Dunmow, Essex CM6 2NX. Tel:
01371 870123 jaysex98114537@aol.com

Trials Recorder

Mr D. Cordle, 4 Bullen Close, Bramford,
Ipswich, Suffolk IP8 4JE. Tel: 01473 462274
the.cordles@talktalk.net

Enduro Recorder

Mr R. G. Hearn, 25 Quinton Road, Needham
Market, Suffolk IP6 8BP. Tel: 01449 721042
jackhverah7@gmail.com

Environmental Officer & Sports Council Representative

Mr E. Wass, 10 Knights Road, Braintree, Essex CM7 3YT. Tel: 01376 331111

Benevolent Fund Officer

Mrs Debbie Blyth
07963118917
blyths21@hotmail.com

0039 Braintree DMCC

Mr John Yearley, 12 Norfolk Gardens, Braintree, Essex CM7 9LE.
Tel: 01376 344844
johnyearley11@aol.com
GT, MX, T

0040 Bury St. Edmunds & DMCC (MX)

Mr N. Sargent Mob: 07793 088713
neilandlynn5@tiscali.co.uk
N&S G

0041 Castle Colchester MCC Ltd

Mr R Norman. Tel: 07421 704255
rn.glfarm@gmail.com
E, MX, T

0042 Chelmsford & DAC

Mr Geoff Brace, 15 Ozier Court, Saffron Walden, Essex. CB11 4BH. Tel: 01799 520366 geoffmx94b@hotmail.com
www.cdac.org.uk
GT, MX, T

0044 Diss MCC Ltd.

Mrs W. Bavin. Tel: 01379 643960
bavinyamah@aol.com
www.dissmcc.co.uk E, MX, T,

0045 Docklands Dirt Riders

Mr C. Salt, Beckton Activity Centre, 7 Hillcroft Road, London E6 6LW. Tel: 0207 473 4434
info@docklandsriders.org.uk
www.docklandsriders.org.uk

0047 Eastern Centre Marshals Club

A. Foskew, 9, Ebenezer Close, Witham, Essex CM8 2HX. Tel: 01376 517169
alanfoskew29@btinternet.com

0048 Eastern Four Stroke Association

Mr Rob Sayers, 29 Roman Way, Long Melford, Sudbury, Suffolk CO10 9LN.
Tel: 01787 370180 Mobile: 07855 607492
henstan@sky.com
T

0049 Eastern Sporting Sidecar Association Mrs

Y. J. Smith, 88 Glebe Road, Kelvedon, Essex CO5 9JS. Tel: 01376 570970
yvonneessa@btinternet.com
GT

0051 Essex & Suffolk Border MCC

Mr P. Fenn, 9 The Crescent, Barham, Nr Ipswich, Suffolk IP6 0PE.
Tel: 01473 830666 666
fenn@gmail.com esbmcc.webs.com
www.facebook.com/
essexandsuffolkbordermcc
MX, T, N&S G

0052 Halstead & DMCC

Mrs Karin Beadle. Tel: 07787 544418
karin6@sky.com
MX

0053 Harwich MCC

Mr L. Barnes, 72 Pound Farm Drive, Dovercourt, Essex CO12 4JZ. Tel: 01255 551088 arijonda34@gmail.com
RR, T, *Ral, Social*

0054 Ilford MC & LCC

Mr D Austin, Broad View Bungalow, The Street, Brundish, Woodbridge, Suffolk IP13 8BL. Tel: 01379 388884
wmengservltd@btconnect.com
T

0055 Ipswich MC & LCC

Mrs P. Cordle, 4 Bullen Close, Bramford, Ipswich, Suffolk IP8 4JE. Tel: 01473 462274 thecordles@tesco.net
MX, T N&S G

0056 Littleport & DMC & LCC

Mr P. Gammon, 9 South Road, Lakenheath, Suffolk. IP27 9AT.
Tel: 01842 861352. Mob: 07902 286239
kinggammon@aol.com
MX, T

0057 Lowestoft Invaders MCC

Mr R. Greengrass, 58 Dell Road West, Oulton Broad, Lowestoft, Suffolk NR33 9NS. Tel: 01502 563566
rjg@rongg58.plus.com
E, T, N&S G

0058 Newmarket MCC

Mrs A Winters. Tel: 01638 603838
anne.winters@yahoo.co.uk
www.newmarketmcc.co.uk
RR *Social N&S G*

0059 Norfolk & Suffolk Jnr. MCC

Mrs Donna Secker
donnaecker@icloud.com MX Sec. Mrs T. Hales. Tel: 01953 453629 Trials Sec. Mr P. Collins. Tel: 01502 568252
YTH/GT, MX, T, N&S G

0606 Norwich New Stars

Laura Pomeroy 72 Horsebeck
Way, Horsford, Norfolk,
NR10 3BB. Tel: 07759 420275
norwichnewstars1998@hotmail.co.uk

0606 Norwich Viking MCC Ltd

A. J. Hay, 27, Tizzick Close,
Norwich, NR5 9HB. Tel: 01603
734700
andrew.hay10@icloud.com
www.norwichvikings.co.uk
MX, T N&S G

0612 St. Georges MCC

Ms D Harvey. Tel: 077305 63553
stgeorges MCC@gmail.com
E, SCH, HH

0603 Southend & DMCC

Mrs Julia Nash, 33 Cherry Orchard,
Southminster, Essex CM0 7HE. Tel:
01621 773131 nap148@aol.com
MX, T, GT

0604 Stowmarket & DMCC Ltd.

Mrs V. Hearn, 25 Quinton
Road, Needham Market,
Suffolk IP6 8BP. Tel: 01449
721042
jackhverah7@gmail.com
E T N&S G

0605 Sudbury MCC

Mr G. Mays, 55 Alan Way,
Colchester, Essex, CO3 4LB. Tel:
07906 09253
grahammays787@gmail.com
E T

0606 Triangle (Ipswich MCC)

Mr Eddie Hood, 25 Angel
Road, Bramford, Ipswich, IP8
4JF. Tel: 01473
748223/07751
116003
thehoods70@gmail.com
www.triangle MCC.co.uk
MX, T, GT, ADLT + YTH N&S G

0607 Triumph Owners MCC (Epping Forest Branch)

Mr E. Mills, 10 St Annes Close,
Cheshunt, Herts EN7 6JA. Tel:
01992 633369 Mob: 07956
560078
e.mills410@btinternet.com
RR & Social

0608 Watton & DMC & CC

Mr B. Catchpole, 76, Bush Road,
Hellesdon, Norwich, Norfolk NR6 7UE.
Tel: 01603 402541

0069 West Essex MCC

Mr C. Crowder, 31 Claremont Road,
Laindon, Essex SS15 5PZ. Tel:
01268 414143
T

0070 Woodbridge & DMCC Ltd

Lyn Ralph, 23 Tymmes Place,
Hasketon, Woodbridge, Suffolk,
IP13 6JD. Tel: 01394
389330/07857 601753
lynralph@outlook.com
E, GT, MX, T

0071 Wymondham & DMC

Mr C. Dopson, 34 Lynch Green,
Hethersett, Norwich, Norfolk NR9
3JT. Tel: 01603 810934 Fax: 01603
813290 Mob: 07710 352489
dopson_boar@msn.com
G, T, T, N&S G

0072 500cc Sidecar Association

Andy Driver, 10 Runnacles Street,
Silver End, Essex, CM8 3QL. Tel:
07739 092189
andydriver2016@gmail.com
www.500ccsidecars.com
G, T,

GROUP**0074 Norfolk & Suffolk Group Clubs**

Mrs Vera Hearn, 25 Quinton
Road, Needham Market,
Suffolk IP6 8BP. Tel: 01449
721042.
jackhverah7@gmail.com
www.barhamsuf.freereserve.co.uk/
nsgrouptrials.htm

4 ACU – EAST MIDLAND

*Area Leicestershire, Derbyshire,
Nottinghamshire, Rutland and Lincolnshire.*

Secretary

Mrs A Boyle, 126 Uttoxeter Road, Hill
Ridware, Nr Rugeley, Staffordshire, WS15
3QX. Tel: 01543 492212
annie126@outlook.com

Chairman

Mr M. Jessup, 54 Monks Road, Binley Woods,
Coventry CV3 2BS. Tel: 02476 544463
mark.jessup@btinternet.com

Treasurer

Mr G Shearing, The Linnets, Main Street, South
Muskham, Newark Nottinghamshire NG23
6EE. Tel: 01636 701437
geoffshearing@gmail.com

Permit Secretary & Police Liaison Officer

Mr. Howard Jones, 3 Nursery Gardens,
Earl Shilton, Leicestershire LE9 7JE
Tel/WhatsApp: 07826 519336
emcpermits@gmail.com

Trials Recorder

Mr M Garrod, 46 West Common Gardens,
Scunthorpe, DN17 1EH. Tel: 01724
346351 garrods@ntlworld

Grass Track Recorder

Rob Smith, 18 Alma Street, Melbourne,
Derby DE73 1GA. Tel: 07877 751278
robsmith.rds66@gmail.com

Benevolent Fund Officer

Annie Boyle, 126 Uttoxeter Road, Hill
Ridware, Nr. Rugeley, Staffordshire WS15
3QX. Tel: 01543 492212/07866 605082
annie126@outlook.com

0075 Banovallum MCC

Mrs Rosemary Hawcock,
Gardeners Cottage, Saxby, Market
Rasen, Lincs, LN8 2DH. Tel: 01673
878768/07736
787339
rosemary.hawcock@listers.co.uk
thehawcocks@gmail.com
www.spanglefish.com/BanovallumMotorcycleClub
T, t, Social

0076 B.M.W. Owners (Sporting Register)

Mr Robert Bensley, Oak Tree
Farm, Heath Road, Banham,
Norwich NR16 2HS. Tel: 01953
888415
robertbensley@btinternet.com
www.bmwclub.org
Social

0078 Burton & District Sporting MCC

Mrs Annie Boyle, 126 Uttoxeter
Road, Hill Ridware, Nr Rugeley,
Staffs WS15 3QX. Tel: 01543
492212/07866 605082
annie126@outlook.com
Training Requirements: Gary Milnes. Tel: 07896
836362 garymilnes@hotmail.co.uk
www.burtonmotocx.com
Basic Training, MX

0080 Cheadle (Staffs) AC

Mr Dave Shields, Kingsley Moor
Cottage, Kingsley Moor, Stoke on
Trent, Staffs, ST10 2EN. Tel:
01538 751745
dshieldsesecplus.co.uk
www.cheadleautoclub.co.uk
T, t

0081 Clubmans Racing Club East Midlands

Dr. Paul King, c/o ACU Road Race
Dept, ACU House, Wood Street,
Rugby, CV21 2YX. Tel: 01788 566400
paul.king@acu.org.uk
RR

0082 Darley Moor MCRRC Ltd

Miss Sandra Nelson, Darley Moor
Sports Centre, Darley Moor,
Ashbourne, Derbyshire. DE6 2ET. Tel:
01335
343833 (Day) Tel: 01246 866537
(Evening) admin@darleymoor.co.uk
www.darleymoor.co.uk
RR, rr

0084 Earl Shilton Trials Club Ltd

Mrs Gail Tuley, 17 Willow Lane,
Cranwell Village, Sleaford,
Lincs, NG34 8DQ. Tel: 07815
565285
estcmembers@hotmail.co.uk
www.estc.co.uk
T, t

0085 Early Stocks Racing Club

Miss Cassandra Beardmore,
Knockinaam Wood Cottage,
Portpatrick, Stranraer, Dumfries &
Galloway DG9 9AG.
Tel: 01776 820827/07710 998216
cass.steve@btopenworld.c
om
www.earlystocksracing.uk
RR

0086 East Midland Racing Association

Mr Mark Jessup, 54 Monks Road, Binley
Woods, Coventry CV3 2BS. Tel/Fax:
02476 544463
mark.jessup@btinternet.com
www.eastmidlandracing.co.uk
RR

0087 FRC

Mr Brian Beck, 36 Fishponds Drive,
Crigglestone, Wakefield, West
Yorkshire WF4 3PB. Tel: 07827
707468 tzbribeck@gmail.com
Social

0099 Grantham Pegasus MC & LCC

Mr Tim Harris, 72 Barrowby
Road, Grantham, Lincolnshire
NG31 8AF.
Tel: 01476 565311
harris.tc@ntlworld.com
Facebook: Grantham Pegasus Trials
T, t, Social

0091 Leicester Grass Track Club

Rob Smith, 18 Alma Street, Melbourne,
Derby, DE73 1GA. Tel: 07877 751278
robsmith.rdss66@gmail.com
GT, gt

0092 Lincoln MC & LCC Ltd

Alison Faulkner, Chapel Lane,
Snitterby, Gainsborough. DN21 4TX.
Tel: 01673 818718
lincoln.secretary@hotmail.com Trial
Enquiries Stuart Alford, Camelot, 18
Grantham Road, Navenby, Lincoln
LN5 0JJ. Tel: 01522 811414/07967
188202.stuart.alford65@sky.com
www.lincolnmotorsport.co.uk
T, t

0814 Lincolnshire Enduro Club

Louise Burford, 1 Stockborough Farm,
Mere Balk Lane, Baumber, Lincs LN9
5PE Tel Day 01507 524040, Eve
01507
578436
lincolnshireenduroclub@aol.co.uk
www.lincolnshireenduroclub.webs.com

0859 Longnor Grasstrack Club

Heidi Bradbury, Underhill Farm, Earl
Stemdale, Buxton, Derbyshire SK17
ORN. Tel: 01298 83882 Mobile: 07966
032079
longnorsports@outlook.com
GT

0093 Loughborough & DMCC

Howard Jones, 3 Nursery Gardens, Earl
Shilton, Leicestershire, LE9 7JE. Tel:
07826 519336
lborotrialsclub@gmail.com
www.loughboroughtrialsclub.co.uk
T, t

0094 Louth & DMCC

Miss Jacqueline Savage, Sandbeck,
Cliff Road, Saxby, Market Rasen,
Lincs. LN8 2DQ
peter.boast1@btinternet.com
ST, QST

0095 Mansfield Maun MCC

Miss Karen Crabtree, Hillcroft, New Mill
Lane, Forest Town, Mansfield, Notts,
NG19 0HH. Tel: 01623 628176/07752
547995 tattytabs@googlemail.com
www.mansfieldmauntrials.co.uk
T, t

0097 North Derbyshire Youth MCC

Mr Alan Nixon, 542 Kedleston Road,
Allestree, Derby DE22 2NG. Tel: 01332
559813 trials08@ndymcc.plus.com
Kevin Stannard. Tel: 07771
612789
kandsscooters@googlegmail.com
www.ndymcc.co.uk
T, t

0098 Pathfinders & Derby MC Ltd

Mr Bryan Tuxford, 15 Westhall Road,
Mickleover, Derby DE3 0PA. Tel:
01332 516861
btuxford@btinternet.com
www.pathfindersandderby.co.uk
T, t

0100 Peterborough Trials Club

Mr Peter Rushbrook, 33 Holmewood,
Holme, Peterborough PE7 3PG.
Tel: 079317 12578 p.rushbrook@sky.com
T, t

0102 Scunthorpe MCC

Niki Louis. Tel: 07745 279617
nikiwright@hotmail.com
www.scunthorpemcc.co.uk
T, t, BT, bt

0103 Sheffield & Hallamshire MC

Richard Timperley, Kenwood
Mount, 270 Newbold Road,
Chesterfield,
S41 7AJ. Tel: 07545 468341 secretary.
sheffandhallamtrials@gmail.com
www.trialstalk.co.uk
T

0104 Skegness MCC

Mrs Nancy Wilson, 12 Staveley Road,
Alford, Lincolnshire LN13 0PN. Tel:
01507 463194
nancywilson281@btinternet.com
www.skegnessmotorcycleclub.co.uk
T

**0854 Stamford & Tallington Orbital
Motorcycle Promotions**

Sarah Kidd, 21 High Street, Swinstead,
Grantham, Lincs NG33 4PA. Tel:
07462 919358
sarahkidd33@yahoo.co.uk

0106 Sutton Falcons MC

John Steeples, 6 Seymore
Lane, Woodthorpe, Derby,
S43 3DA
www.suttonfalcons.com
T, t

0108 Wainfleet & District Sporting MCC

Mrs Sheila Blackbourn, New Farm, Wainfleet Bank, Wainfleet St. Mary, Skegness, Lincoln PE24 4JP. Tel/Fax: 01754 880659
reg.blackbourn@btopenworld.com
www.superspeedtrack.com
GT, qt, LT

5 ACU – EAST SOUTH WALES

Area Gwent, South Glamorgan, those parts of Mid Glamorgan and the Brecknock District of Powys situated east of a line from Porthcawl through Aberdare to Builth Wells.

Secretary/Treasurer/Permit Secretary

Mr Derek Smith, Crosswinds, 13 Julians Close, Gelligar, Caerphilly, CF82 8DT. Tel: 01443 556407/07971 153903

derek.acu.eastsouthwales@gmail.com

Chairman

Mr A. L. King, 95 Marlborough Road, Cardiff CF2 5BW. Tel: 029 2048 2559
aking973@yahoo.co.uk

Police Liaison Officer/Benevolent Fund Officer

Mr Derek Smith, Crosswinds, 13 Julians Close, Gelligar, Caerphilly, CF82 8DT. Tel: 01443 556407/07971 153903

derek.acu.eastsouthwales@gmail.com

Child Protection Officer

Mrs Sharn Gibbs, 63 Beech Court, Burgbed, CF81 8NS. Tel: 01443 829419.

sharny@yahoo.co.uk

0109 Aberaman & DMCC

Ian McLeod, 6 Raven Road, Yoxall, Burton On Trent, Staffs, DE13 8PY.

Tel: 07860694548

ian_mcleod2@sky.com

0110 Abergavenny Auto Club

Mr Mike Roberts, Pwll Mair Farm, Llanvihangel Crucorney, Abergavenny, NP7 8EF. Tel: 01873 890371

mickeyrobs50@gmail.com
www.abergavennyautoclub.co.uk
MX, T, t

0665 Blackwood & District Motor Club Ltd

Mikki Down, 30 High Street, Ynysddu, Caerphilly NP11 7JJ. Tel: 01495 201099/07531 860318

miksdup001@yahoo.co.uk

RR, rr, RAL

0114 Cardiff Motor Club

Mr A. L. King, 95 Marlborough Road, Cardiff CF2 5BW. Tel: 029 2048 2559
aking973@yahoo.co.uk

0113 Caerphilly & District MC & LCC

Paul Martin, 5 Meadowgate, Pontllanfraith, Blackwood, Caerphilly. NP12 2RB. Tel: 07979 857084.

paulmartin24@hotmail.co.uk
caerphillymcc.co.uk
LDT, E, SCE, HH

0539 Ecurie Cymraeg

Mr Steve Durbin, 9 Llanover Street, Abercarn, Newport. NP11 4SX. Tel: 01495 243990. steve@acurie-cymraeg.co.uk

0118 Gilfach Triangle Motor Club

Mr Keith Green, 76 Gilfach Stree, Baroged, Mid Glamorgan. CF81 8LR. Tel: 01443 832036.
kwjgreen@talktalk.net

0119 Gwent Schoolboy Trials Club

gwent-schoolboystrialsclub@btinternet.com

T, t

0122 Merthyr Motor Club

Mr Steve Williams, c/o 14 Park Crescent, Thomastown, Merthyr Tydfil, South Wales CF47 0EU. Tel: 07802 230028/01685

386209 geoffrey.snow1@btinternet.com
T

0125 Pontypool & DMCC

Mr Evans. evans-luter@tiscali.co.uk

T, t

0126 Rhondda Motor Club

Michael Neale, 13 St Johns Drive, Ton Pentre, Pentre Rhondda Cynnon Taf, Mid Glamorgan, South Wales

membership@rhonddamotorclub.org.uk
RAL

6 ACU – EAST YORKS

Area that part of Stockton Borough situated south of the River Tees, Middlesbrough Borough, Redcar & Cleveland Borough, that part of North Yorkshire situated east of the railway line from Northallerton to the boundary of York (including York), and east of the main York – Barby – Howden to the East Yorkshire boundary and the area of East Yorkshire situated north of the Rivers Humber and Ouse.

Secretary

Mrs A. Watson, Dunriding, High Street,
Castleton, Whitby YO21 2DB. Tel: 01287
660577 aecwatson@gmail.com

President

Mr. Dave Wilkinson, Garth House,
Scarborough Road, East Heslerton, Malton
YO17 8RW.

Tel: 01944 728301

Chairman

Mr D. Willoughby, Brambles, Sessay, Thirsk,
North Yorkshire, YO7 3BE. Tel: 01845
501448 willoughby.moto@gmail.com

Permit Secretary & Police Liaison Officer

Mr J. W. Filer, 23 Rievaulx Way,
Guisborough TS14 7AR. Tel: 01287
634404 william.filer@ntlworld.com

Treasurer & Benevolent Fund Officer

Mrs E. Race, 20 Broadlands Drive, East Ayton,
Scarborough, North Yorkshire YO13 9ET.

Tel: 01723 863987 erace@hotmail.co.uk

0131 Eboracum MCC of York

Mrs. Sarah Laws, 14 Spitfire Close,
Scorton, Richmond DL10 6TF. Tel: 01748 818791
eboracumtrials@hotmail.co.uk
www.eboracummotorcycleclub.co.uk
T, t

0132 Guisborough & DMCC Ltd

Mrs Hannah Arbon, 7 West Terrace,
New Marske, TS11 8HD. Tel: 07717
765272
hannaharbon82@hotmail.com
www.guisboroughdmc.co.uk
T, t

0133 Hull Auto Club

Mr James Austermuhle, East The Lodge,
Rosedale Abbey, Pickering, North
Yorkshire, YO18 8SE. Tel: 01751
417455
jim.austermuhle@btopenworld.com
T, t

0136 Middlesbrough & DMC

Mrs. Jacqueline Lawson, 20 Ryefield
House, Barley Hill Close, Eston,
Middlesbrough, TS6 0TH. Tel: 077207
13892 lawsonjaxx@gmail.com
www.motorclub.uk.net
HC, T

0137 Northallerton & District Motorcycle Club Ltd

Mr. D. Fawcett Tall Trees,
Morton on Swale,
Northallerton, N. Yorks DL7
9RN. Tel: 01609 775578
trishfawcett@1cloud.com
T

0138 North Yorkshire Road Racing Supporters Club

Mr. Max Coates, The Holmelands,
Scorton, Richmond, DL10 6DH.
Tel: 07783 725728/01748
818892
max@nyrrsc.co.uk www.nyrrsc.net
Social

0140 Pickering & DMC

Mr D. A. Brown, 4 Brockfield
Road, Huntington Road,
York YO31 9DZ. Tel: 01904
622274
davidbrown533@btinternet.com
MX, mx, GT, gt, T, t

0595 Ryedale Motorcycle Club Ltd

Mr. Alan Wright, Rawcliffe Cottage,
Stape, Pickering YO18 8HZ. Tel: 07776
370259 oldalan@icloud.com
ryedalemc@outlook.com
www.ryedalemc.com
E

0141 Scarborough & DMC

Mrs. Anne Wilkinson, Garth House,
Malton Road, East Heslerton,
Malton York YO17 8RW. Tel: 07876
510454
generalsec@scarboroughdmc.com
Membership Secretary: Mrs
Maureen Galway. Tel: 01723
870506
www.scarboroughdmc.co.uk
T, t

0143 Thirsk & DMC

Mr. Peter Almack, 65 Topcliffe
Road, Sowerby, Thirsk YO7 1RT.
Tel: 07764 786670
MX, T, t

7 ACU – ISLE OF MAN

Area Isle of Man.

Secretary

Miss Lizzie Kinvig, 1 The Crofts, Ballaughton
Meadows, Douglas IM2 1JQ. Tel: 07624 200470
lizziekinvig@gmail.com

Chairman

Mr Gareth Temple, Rosedene, Main Road, Ballabeg, Isle of Man, IM9 4 HA. Tel: 07624 201298

garethtemple@hotmail.com **Treasurer**

Mr Tony Temple, 12 Raad Ny Gabbil, Castletown, Isle of Man, IM9 1HH. Tel: 07624 390931 tonytemple@manx.net

Permit Secretary

Mr Tony Temple, 12 Raad Ny Gabbil, Castletown, Isle of Man, IM9 1HH. Tel: 07624 390931 tonytemple@manx.net

Rights of Way Officer

Mr Julian Wood, Ballakinnag House, Shore Road, Ballaugh, Isle of Man IM7 5AZ. Tel: 01624 890250 jmwood@manx.net

Benevolent Fund Officer

Mrs W.Evans MBE, 3 Mount View Terrace, Onchan, Isle of Man IM3 1AB. Tel: 01624 621296 Mob: 07624 433540

desandwyn@manx.net

acubenfundiom@manx.net

Manx National Two Day Trial – Secretary of the Meeting

Ms Cheryl Baxter, 10 Fenella Terrace, Peel, Isle of Man, IM5 1PL. Tel: 07624 232010

chezbax@gmail.com

0145 Andreas Racing Association Ltd

Neal Champion, 29 Fairway Drive Ramsey, Isle of Man, IM8 2BD, Tel: 07780 666178 / 01624 813503

chairman@andreasracing.im

RR

0146 Isle of Man Schoolboy Motor Cycling Club Ltd

Donna Shand. Tel:07624 474241 donnab@manx.net

MX, mx

0147 Isle of Man Youth Trials Club Ltd

Sharon Louise Christian, 16 Woodlands View, Farmhill, Douglas, Isle of Man, IM2 2BT. Tel: 07624 463496

sharon_l_christian@manx.net

T, t

0542 Manx Grass & Sand Racing Motorcycle Club

Zoe Salmon, 69 SliEAU curn Park, Kirk Michael, Isle of Man, IM6 1EW. Tel: 07624 403242 manx.g.s.r@hotmail.com

MX, mx, QMX, qmx, GT, gt, SR, sr, QGT, E

0148 Manx MCC Ltd

Mrs Ann Kinvig, MMCC Office, The Grandstand, Glencrutchery Road, Douglas, Isle Of Man, IM2 6DA Tel: 01624 644649 ann@mgp.co.im
mgp@manx.net www.manxgrandprix.org RR

0149 Peveril MC & LCC Ltd

Mrs Blanaid Higgins, 29 Ballanawin, Strang, Isle of Man, IM4 4NS. Tel: 07624 219046

MX, mx, QMX, T, t, LDT, bk, AT, at, E

0150 Ramsey MCC Ltd

Mrs Kelly Kerry, 5 Reayrt aaylin, Peel, Isle of Man, IM5 1US. Tel: 07624 357037

k.at@manx.net

MX, mx, BC, QMX, T, t, HH

0151 Southern MCC Ltd

Mrs Brenda Crellin, Shilley Gniebe, Ballachurry Road, Greeba, Isle of Man IM4 3LE. Tel: 01624 801726

brenda@southernmcc.com
www.southernmcc.com

T, t, E, SCE, HH, RAL

0152 Southern 100 MCR Ltd

Mr George Peach, Ellerslie House, 128 Malew Street, Castletown, Isle of Man IM9 1LT. Tel: 07624 471301 Fax: 01624 822546

georgepeach@manx.net
www.southern100.com

RR

0153 Vintage MCC Ltd (IOM Section)

Mr Rupert Murden. Tel: 01624 851686

murdy916@hotmail.com
www.vmcioim.org

T

8 ACU – MIDLAND

Area Shropshire: The Stafford, South Staffordshire, Cannock Chase, Lichfield, Tamworth, East Staffordshire and the Staffordshire Moorlands, Districts of Staffordshire; West Midlands; Warwickshire, those areas of Hereford and Worcester and Gloucestershire, north of a line from Brimfield through Worcester; Evesham and Moreton-in-the-Marsh to the junction of the Oxfordshire and Warwickshire boundaries.

Secretary

Mr G Archer, 67 Mayswood Road, Solihull, Wets Midlands, B92 9JE. Tel: 0121 743 3220

centresecacumidland@gmail.com

Chairman

Mr T. Fairbrother, 14 Spring Grove Road,

Kidderminster, Worcester DY11 7JA. Tel: 01562 754827

tim.fairbrother@btinternet.com **Treasurer**
Mr J. Wells, 6 Walkers Way, Coleshill,
Birmingham. B46 3DA. Tel: 01675 466810.
johnwells206@btinternet.com

**Permit Secretary, Police Liaison Officer &
Trials Recorder**

Mr R. Gill, 23 Hillwood Ave, Shirley, Solihull,
West Midlands B90 4XR. Tel: 0121 246 5823
gill.rf@gmail.com

Motocross Recorder

Mr M. Francis, Nant yr Arth, Dolywern,
Pontfaddon, Llangollen LL20 7AE. Tel: 01691
718199 mike4u@aol.com

Grass Track Recorder

Mrs D. Edwards, Oak Lodge, Buckwyns
Chase, Billericay, Essex CM12 0TN. Tel: 01277 654829

dawn@edwardsandson.co.uk

Grass Track Co-ordinator

Mr Matthew Wear, 25 Ffordd Dyfrig, Tywyn,
Gwynedd, LL36 9EH. Tel: 07788 412062.
matthewwear666@gmail.com

Centre Trials Secretary/Chairman

Mr G. Archer, 67 Mayswood Road,
Solihull, West Midlands B92 9JE. Tel: 0121 743 3220.

centresacumidland@gmail.com

Benevolent Fund Officer

Mr & Mrs G. Daniel, 25 Doidge Road,
Erdington, Birmingham B23 7SQ. Tel: 0121
3502601 beryldaniel@btconnect.com

0154 Antelope MCC (Coventry) Ltd

Ms Janet Twamley, 21
Ashfield Road, Kenilworth
CV8 2BE. Tel: 01926 512876
or 07933
199006 email@antelope-
mcc.co.uk
info@pandjotowbars.co.uk
www.antelope-mcc.co.uk
Social

0156 Bewdley MCC

Mrs Diane Mantle. Tel: 077347 61047
dimantle@hotmail.com
GT, T, E, Social

0157 Birmingham Motor Cycle Club

Mr Graham Harrison, 26 Fieldon
Close, Shirley, Solihull, West Midlands
B90 3EA. Tel: 0121 745 2557/07801
729063.
graham.harrison26@sky.com

T

0158 Dudley & District MCC

Mr Peter Cartwright, 54
Wolverhampton Road, Kidderminster,
Worcester DY10 2UT. Tel: 01562
820259/07918 130861
petercartwright123@yahoo.com
T, t

0159 Evesham MCC

Mr Dave Kimberley, Honey Dew, Plough
Road, Tibberton, Worcester WR9 7NQ.
Tel: 01905 345395
p.wic615813@aol.com *GT, T, t*

0834 JCR Promotions

Mr Carl Pugh. Tel: 07411 459161
pugh557@btinternet.com

0161 Kings Norton MCC

Mr Gordon Green, c/o TRIO, PO Box
14867, Birmingham, B18 9EN. Tel:
0121
748 4826. Sports Secretary: Mr Martin
Taylor, 225, Callowbrook Lane,
Rubery, Birmingham. B47 9TG. Tel:
0121 453
5144.

0162 Leamington Victory MC & LCC

Mr Alan Halford, 109 Palmer Road,
Whitnash, Leamington Spa,
Warwickshire, CV31 2HR. Tel: 01926
730525 Mob: 07941
072073 hon.sec@leamingtonvictory.org.uk
GT, T, t

0163 Market Drayton MCC

Mr Robin Barrett, 21 Ashwood
Close, Market Drayton, Shropshire
TF9 3HF. Tel: 01270 624676 Mob:
07985 228905 T

0640 Midshires Grasstrack Club

William Ward, 9 Beaton Road, Four
Oaks, Sutton Coldfield, West Mids B74
4RU. Tel: 121 308 5711/07887
427349
williamward6@icloud.com
GT, gt

0165 Minsterley MC

Mr Ross Wharton, c/o 2 Holly
Cottages, Rowton,
Shrewsbury, SY5 9EH Mob:
07793 114987
rosswharton25@gmail.com
GT, gt

0166 Redditch MCC

Mr David Smith, The Willows, Cursley
Lane, Shenstone, Kidderminster,
Worcs, DY10 4DX. Tel: 01527
592797/01299 253819 Mob: 07850
6310143
dave@globalpump.co.uk

T

10168 Salop Motor Club

Mr Paul Pitney, 2 Islington Farm Cottages, Northwood, Wem, Shropshire, SY4 3UG. Tel: 01939 232286 Mob: 07816 641077
paulpitney@hawk-group.co.uk
MX, mx, BT, bt

10169 South Birmingham Motor Club

Mr Tim Fairbrother, 14 Spring Grove Road, Kidderminster, Worcester DY11 7JA. Tel: 01562 754827
tim.fairbrother@btinternet.com
T

10170 South Shropshire MCC

Leueen Lawley, Crossing Cottage Long Lane, Craven Arms, Shropshire, SY7 8DU. Tel: 01588 672415
leueen.lawley1@btinternet.com
T, t

10171 Stafford Auto Club

Mr D Wood, 31A Chester Road, Sutton Coldfield, West Midlands, B74 2HP. Tel: 0121 353 2355/Mob: 07931 669549
dajwood@aol.com
Tt

10173 Staffs Moorlands MCC

Mr Pat Trafford, Tamarind, Sandybrook Lane, Leek, Staffs, ST13 5RZ. Tel: 01538 386451
p.trafford@sky.com
T

10174 Stourbridge Trials Club

Mr P Rainsford, 2 Homestead Cottages, Monkhopton, Bridgenorth, Shrops WV16 6SB. Tel: 07929 345791
T, t

10172 Stratford Upon Avon MCC

Mr Alex Tyrer, 20 Sandfield Lane, Newbold on Stour, CV37 8UN
Mob: 07939 066004
alex.tyrer@gmail.com
www.stratfordmcc.co.uk
T, t, LDT

10779 Worcester GrassTrack Racing Club

Geoff Davis. Tel: 07973 857293
worcestergrasstrack@outlook.com

10177 Wrekin Bantam Grass Track Club.

Mrs Alison Alder, 44 Sidons Road, Tupsley, Hereford, Worcs, HR1 1XD.
Tel: 01432 371509
alder.alison@gmail.com or
alder.rob@gmail.com
www.wrekingrasstrack.com
GT

9 ACU – MID WALES

Area that part of Meirionnydd district of Gwynedd situated south of a line from the junction of the Gwynedd/Powys/Clwydd boundaries through Maentwrog District boundary. The Montgomery and Radnor districts of Powys, those parts of the Brecknock district

of Powys and the Ceredigion District of Dyfed situated north of a line from Aberystwyth to Builth Wells.

Secretary

Pam James, Haul a Gwynt, Trem Dyffryn, Red Bank, Welshpool, Powys, SY21 7PT. Tel: 01938 555548 dpjamesuk@yahoo.co.uk

Chairman

Dylan Jones

Treasurer and Permit Secretary

Jessica Hockly, 1 Plas y Bryn Bungalaw, Llanfair Road, Newtown, Powys SY16 3JY.

Tel/Fax: 01686 626370
jess_hockly@yahoo.co.uk
www.midwalesdirtrack.com

Benevolent Fund Officer

Mr M. Bates, Nant-yr-Wyn, Llanbister Road, Landrindod Wells, Powys LD1 5UP. Tel: 01547 550393

10178 Aberystwyth & DMCC

Mr Phil Rowley, 2 Maes Y Felin, Penrhyncoch, Aberystwyth, SY23 3EN.
Tel: 07838 233318
rowers1971@live.co.uk;
admcc@admcc.co.uk
www.admcc.co.uk E, HH, T, t

10181 Bro Cader MCC

Mr Colin Hughes, 72 Manod Road, Blaeneu Ffestiniog Gwynedd, North Wales LL41 4AF. Tel: 01766 831075
colbro300@gmail.com
www.brocader.com
T, t, HH

10179 Builth Wells Motor Club

Mr Dan Baynham, Mandinam, Broadway, Llandrindod Wells, Powys. LD1 5HT. Tel: 07799 212574
dan.baynham@gmail.com
T, E, HH

10183 Central Wales Auto Club

Kevan James, 9 Rockes Meadow, Knighton, Powys, LD7 1LE. Tel: 01547 528965 wobbs450@btinternet.com
cwacknighton@yahoo.com
E, T, HH

0184 Clive MCC Ltd

Pam James, Haul y Gwynt, Trem Dyffryn, Red Bank, Welshpool, SY21 7PT. Tel: 01938 555548
dpjamesuk@yahoo.co.uk
www.clivemcc.co.uk
T, t, RAL

0185 Hafren Dirt Bike Club

Dylan Jones, Glynhafren, Old Hall, Llanidloes, Powys, SY18 6PS info@hafrendbc.co.uk
www.hafrendbc.co.uk
E, HC

0849 Llandrindod Wells & DMC

Sian King, 8 Cortay Park, Llanyre, Llandrindod Wells, Powys, LD1 6DT. Tel: 07723 015287
gazkvf@hotmail.co.uk *T, t*

0186 Lanfyllin & District MCC

Elwyn Williams, Three Chimneys, Llansantffraid, Powys SY22 6AX. Tel: 01691 828330 Fax: 01691 829396

0725 Peterchurch Grass Track Club

Mrs Sheila Swann, The Princes, Peterchurch, Herefordshire HR2 0RT. Tel: 01981 550621 Mob.: 07881 944 648
theprinces123@tiscali.co.uk
GT, T

0189 Rhayader MC & LCC Ltd

Miss Anne Bates, Little Gigrin, Rhayader. Powys LD6 5NU. Tel: 01597 810435
www.2013.rdmcc.co.uk
MX, T, t, HH, E

10 ACU – NORTHERN**Area Cumbria.****Secretary**

Mrs Maxine Hayhurst, Natland Park Farm, Natland, Kendal, Cumbria LA9 7QD. Tel: 01539 721115 Mob: 07712 814190
natlandpark@hotmail.co.uk

Chairman

Mr Robert Wilson MRICS 14 Undercliff Road, Kendal, Cumbria LA9 4PS. Tel: 01539 728565/07484 642118
mec27@btinternet.com **Vice Chairman**
Mr Angus Jenkinson, Hill Crest, Backbarrow, Ulverston, Cumbria, LA12 8QP. Tel: 01539 531766

President

Keith Quinn, 7 Arkholme Close, Carnforth, LA5 9XF. Tel: 01524 732089
mark@dynostart.com **Treasurer/Police Liaison Officer & Permit Secretary**

Sheila Murphy 18 Spring Vale, Trinkfield Park, Swarthmoor, Ulveston, Cumbria, LA12 0XA. Tel: 01229 581978

Permit Secretary

Sheila Murphy 18 Spring Vale, Trinkfield Park, Swarthmoor, Ulveston, Cumbria. Tel: 01229 581978
sheilamurphy95@yahoo.co.uk

Rights of Way Officer

Mr Robert Wilson MRICS 14 Undercliff Road, Kendal, Cumbria LA9 4PS. Tel: 01539 728565/07484 642118
mec27@btinternet.com **Motocross Recorder**

Recorder

Mrs Sheila Murphy 18 Spring Vale, Trinkfeld Park, Ulverston, Cumbria. Tel: 01229 581978
sheilamurphy95@yahoo.co.uk

Trials Recorder

Anthony Hayhurst, Natland Park Farm, Natland, Kendal LA9 & QD. Tel: 01539 721115. natlandpark@hotmail.co.uk

Benevolent Fund Officer

Mr Keith Quinn, 7 Arkholme Close, Carnforth, LA5 9XF. Tel: 01524 732089
mark@dynostart.com

0790 Barrow and District Motorcycling Club

Katie Thistlethwaite, 47 Trinkeld Avenue, Swarthmoor, Ulverstonb, Cumbria LA12 0XB
katie4282@hotmail.com

0569 Bassenthwaite and District Motor Club Ltd

David Sharp, 3 Albemarle Street, Cockermouth, Cumbria CA13 0BG. Tel: 01900 828207
bassenthwaiteanddistrictmc@gmail.com

0192 Bootle Scrambles Club

Mrs Anne Leece, "Riverside", Hallthwaites, The Green, Millom, Cumbria LA18 5HP. Tel: 01229 772502/01229 773900
eadmin@haverigg.cumbria.sch.uk
T, t

0193 Cumberland County MCC Ltd

Mr Frank Smith, 215 Blackwell Road, Carlisle, Cumbria CA2 4DN. Tel: 01228 532307 annfra2400@hotmail.com
T, t

10196 East Cumbria Moto X Club

Kath Lawson, Bank End Farm,
Maryport, Cumbria, CA15 6PA. Tel:
01900 817202
kathlawson@hotmail.co.uk
MX, mx

0735 Fell Side Auto Club Ltd

David Sharp, 3 Albemarle Street,
Cockermouth, CA13 0BG
sharpy1966@hotmail.com

10197 Lakes Grass Track Racing Club

Colin Benson, 41
Hallagarth Circle, Kendal,
LA9 5NY.
Tel: 01539 729714/077969 25762
colinbenson41@btinternet.com

T, t Social

10198 Lakes Motorcycle Trials Association Ltd

Mick Wren, Levenside, Newby Bridge,
Ulverston, Cumbria LA12 8LZ. Tel:
01539 531082 mick.trials@gmail.com
T

0497 West Cumbria Motocross Club

Miss Susan Carling, Dean Cross
Cottage, Lamplugh, Workington,
Cumbria CA14 4RH. Tel: 01946
862020 Fax: 01946
861225
westcumbriamx@btconnect.com
www.deanmoormotocrosspark.co.uk
MX, mx, QMX, qmx

10202 Westmorland Motor Club Ltd

Kimberley Winder, 42
Mayfield Avenue, Holme,
Carnforth, Lancs, LA6 1PT.
Tel: 07891
144235 admin@wmcevents.co.uk
www.westmorlandmotorclub.co.uk
HC, T, t, BT, bt, HH

11 ACU – NORTH EASTERN

*Area Northumberland, Tyne & Wear, those
parts of Durham and Cleveland situated north
of the River Tees.*

Secretary

Mr Steve McCauley, 6 Brecon Close, Wansbeck
Manor, Ashington, Northumberland NE63
0HT. Tel/Fax: 07747 864384
steve.mx@aol.com **President**

Mr Alan Mills, 12 Fern Terrace, White le
Head, Stanley, County Durham, DH9 9SQ. Tel:
01207 280990

Vice Presidents

I Reavely, 35 Columbia Terrace,
Blythe, Northumberland, NE24 3JZ
ianreavley007@btinternet.com

John Hutchinson. Tel: 0191 252 4723/07867
791205 hutch50@btinternet.com

Chairman

Mr F. Nicholson, 9 Highbury Avenue,
Springwell, Gateshead, Tyne and Wear.
Tel: 0191 417 8326
frednich01@ntlworld.com
john@nicholson-eng.co.uk

Vice-Chairman

Mr Colin Battensby, 30 Honister Way,
Woodlands Park, Blyth, Northumberland
NE24 3XB colin@bedlingtonmotorclub.co.uk
Ray Crinson. Tel: 0191 548 4664/07891
370003

ray.crinson@btopenworld.com

Treasurer

Mr John Guthrie, 9 Hillside Gardens,
Sunderland SR2 9AR. Tel: 0191 522
6260 guthaz@ntlworld.com

Police Liaison Officer

Mr Steve McCauley, 6 Brecon Close, Wansbeck
Manor, Ashington, Northumberland NE63 0HT.
Tel: 07747 864384 steve.mx@aol.com

Permit Officer

Mr F. Nicholson, 9 Highbury Avenue,
Springwell, Gateshead, Tyne and Wear.
Tel: 0191 417 8326
frednich01@ntlworld.com
john@nicholson-eng.co.uk

Trials Recorder

Mr Colin Battensby, 30 Honister Way,
Woodlands Park, Blyth, Northumberland
NE24 3XB.

Motocross Recorder

Mr Steve McCauley, 6 Brecon Close, Wansbeck
Manor, Ashington, Northumberland NE63 0HT.
Tel: 07747 864384 steve.mx@aol.com

Environmental Officer

Mr F. Nicholson, 9 Highbury Avenue,
Springwell, Gateshead, Tyne and Wear.
Tel: 0191 417 8326
frednich01@ntlworld.com
john@nicholson-eng.co.uk

Benevolent Fund Officer

Mr John Guthrie, 9 Hillside Gardens,
Sunderland SR2 9AR. Tel: 0191 522
6260 guthaz@ntlworld.com

0203 Bedlington & DMC

Mr Colin Battensby, 30 Teal
Avenue, South Beach Estate,
Blyth, Northumberland, NE24
3PT.
colin@bedlingtonmotorclub.co.
uk
www.bedlingtonmotorclub.co.u
k T, t

0762 Blyth Valley Motocross Club

Carol Johnson, 36 Kingsdale Ave,
Blyth, Northumberland NE24 4EN.
Tel: 07724 704036
johnsonc441@aol.com Peter
Johnson. Tel: 07955 515977
MX, mx

0866 Blue Barns MX Club

Brian Somerville, 22 Denesyde,
Medomsley, Consett, Co Durham,
DH8 6PX. Tel: 07826 845947
b.spavers@hotmail.co.uk
MX, mx

0583 Castleside Trials Club

Ossy Byers, 10 Chapel Drive,
Woodside, Delves Lane, Consett, Co
Durham DH8 7EW. Tel: 07818 056207
T, t

0204 Consett & DMC

Graham Turpin, 22 Harvey Close,
North Seaton, Ashington,
Northumberland NE63 9EH
T, t

0205 Durham County TC

Mr Fred Nicholson, 9 Highbury
Avenue, Springwell, Gateshead, Tyne &
Wear NE9 7PX. Tel: 0191
4162041/0191
4178326
frednich01@ntlworld.com
john@nicholson-eng.co.uk
T, t

0206 Falcon Motocross Club

Mr Steve McCauley, 6 Brecon Close,
Wansbeck Manor, Ashington,
Northumberland NE63 9HT. Tel:
07747 864384 steve.mx@aol.com
MX, mx

0208 Iveston & Satley MCC

Karl Robinson. Tel: 07711 556470
karl.robinson@fillpack.co.uk
MX, mx, QMX

0803 MECVC

President: Joe Pinkney. Chairman:
Bernie Pugh. Tel: 07835 407626.
Secretary:
Peter Phillips. Tel: 07477 354535
peterphillips.mecvc@gmail.com.
Sports/ Trials Secretary Bernie Pugh.
Tel: 07835 407626
berniepugh.mecvc@gmail.com
www.durhamdalesclassictrial.org.uk

0209 Newcastle & DMC Ltd

John Hutchinson, 21 Station Road,
Forest Hall, Newcastle Upon Tyne,
NE12 8AP. Tel: 0191 2524723. Mob:
07867 791205
hutch50@btinternet.com
T, t

0212 North East Motor Cycle Racing Club

Donna Davison. Tel: 01670 362267
Mob: 07766 074684 rsnemcrc@gmail.com
www.nemcrc.co.uk
RR

0214 Northumbrian Classic MCC

Mr Raymond Newell, 2 Store House,
Low Westwood, Newcastle upon Tyne
NE17 7PL. Tel: 0191 2527373/01207
561890
RAL, Social

0215 Seaton Delaval & DMC

Ray Crinson, 14 Prengarth Avenue,
Fulwell, Sunderland, Tyne & Wear SR6
9HX. Tel: 0191 548 4664/07891
370003
ray.crinson@btopenworld.com
T, t

0216 South Shields & DMC

Mr John Guthrie, 9 Hillside Gardens,
Sunderland, Tyne & Wear SR2 9AR.
Tel: 0191 522 6260 guthaz@ntlworld.com
T, t

0599 Stanley Trials Club

Graham Turpin, 22 Harvey Close,
North Seaton, Ashington,
Northumberland NE63 9EH
T, t

0217 Tweed Valley MCC

Mr John Palmer, 12 Prince Charles
Road, Scremerston, Berwick on
Tweed, Northumberland TD15 2RG.
Tel: 01289 302057
palmer001@btinternet.com
T, t

0218 Tynemouth & DMC

Mr Garry Salmon, The Clubhouse,
Billy Mill Lane, Billy Mill, North
Shields, NE29 8LP. Tel: 07931 247
448
www.tynemouthmotorclub.co.uk
T, t

0220 Weardale & DMC

Mr Alan Winter, 15 Nelson Street, Crook,
Co. Durham DL15 9HJ. Tel: 07900
288705
alspan.aw@googlemail.com
T, t

12 ACU – NORTH WESTERN

Area Lancashire; those parts of Greater Manchester situated north of the Rivers Mersey and Tame, those parts of Cheshire situated north of the estuary of the River Mersey and north of the Manchester Ship Canal; Merseyside (excluding Wirral District).

Secretary

Mrs Chloe Heton, 15 Knightswood Beaumont Chase, Bolton, BL3 4UU. Tel: 077881 40682
chloe29@gmail.com

President

Mr R Livesey 37 Doodstone Avenue, Lostock Hall, Preston, PR5 5TY. Tel: 01772 627343/07806
753433 hondabobs@btinternet.com

Chairman

Mr K. Wilson, 102 Waddicar Lane, Melling, Liverpool L31 3DY. Tel: 0151 5472286
kwillo21@gmail.com

Treasurer & Permit Secretary & Police Liaison Officer

Mr Alex Sykes, 16 Avonhead Close, Horwich, BL6 5QD. Tel: 07910 765467
alex@alexsykes.net

Benevolent Fund Officer

Mr Adrian Brown, 20 albany Drive, Walton Le Dale, Preston, Lancashire, PR5 4TY. Tel: 07863 557183
adrian@deklanbrown.com

Grass Track Recorder

Mr A. Brown 20 Albany Drive, Bamber Bridge, Preston, Lancs. Tel: 07863 557183
adrian@deklanbrown.com

Road Race Recorder

Mrs Pamela Redmayne
pamelaredmayne@hotmail.com

Trials Recorder

Mr Chris Kirkbride, 64 Farmdale Road, Lancaster Lancs LA1 4JD. Tel: 07941 554394
c.kirkbride@sky.com

Rights of Way Officer

Mr Robert Baldwin, 3 Benjamin Row, Green Haworth, Oswaldtwistle, Lancashire BB5 3RZ. Tel: 01254 872727/01254 383808

0222 Aintree MC Racing Club Ltd

Mr Paul Buxton, 146 Brookfield, Cheadle, Stockport, Cheshire SK6 1EY. Tel: 07810 677656 or 0161 491 6657
p.buxton@aintreemrc.co.uk
www.aintreemotorcyclercyclingclub.co.uk
k RR

0224 Ashton Under Lyne & DMC

Mr E. Adcock, 19 Oxbow Way, Whitefield, Manchester M45 8SG. Tel: 0161 767 9239
eric-adcock@sky.com
Social

0225 Bolton Motorcycle Club

Mr Paul Knight, 36 Sherbourne Road, Heaton, Bolton, BL1 5NW. Tel: 01204 843056/077489 64194
ppknight41@gmail.com
T, t

0226 Bury & DMC

Mr Jack Isherwood, Riverdene, 43 Beatham Road, Milnthorpe LA7 7QN. Tel: 01539 563144
MX, T

0227 Chorley MX Club

Mr David Jagger, 4 Claytongate Drive, Penwortham, Preston, Lancs PR19SE. Tel: 07760 434360/01772 316262
MX, SCE, HH

0228 Darwen MC & CC

Mr Alex Sykes, 16 Avonhead Close, Horwich, BL6 5QD. Tel: 079107 65467
secretary@darwentrials.club
www.darwentrials.club
T

0229 East Lancs MC & LCC

Mr David Banks, 681 Preston Old Road, Fenisowles, Blackburn, Lancs BB2 5EN. Tel: 01254 201906
Social

0230 Fleetwood & District MCC

Mr Peter Richardson, 21 Kendal Avenue, Little Carleton, Blackpool, Lancs FY3 7LG. Tel: 01253 595599/01253 396991
Social

0233 Lancs County MCC

Mr Mike Rapley, 3 New Acres, Carnforth, Lancs LA5 9XD. Tel: 07788 161929/01524 734674
rapley47@outlook.com
www.lancscountymcc.co.uk
T, t

0755 Lancashire Off-Road Grasstrack Association (LOGA)

Mr Mark Heaton, 49 Meadow Ave, Preesall, Lancs FY6 0HA. Tel: 07946 542558/01253 812557
mark.heaton@talktalk.net
GT, MX

Leisure Lakes Classic Trials Club Mr
Oddie Danaan 19 Parkgate Drive,
Leyland, Lancs PR25 1BU. Tel:
07900 036380
odgie633@gmail.com
T, t

0236 Marshals North West

Mike Clear, Pole Royd Farm, Hey
Lane, Scammonden, Huddersfield,
HD3 3FW Mob: 07887 553325
secretary@marshalnw.co.uk
Sprint

0237 Mersey MCC

Mr Alan Owens, 125 Rhodesia Road,
Aintree, Liverpool L9 9DT. Tel: 0151
474 5785
S, T

0240 Pennine Range MC

Mr Robert Baldwin, 3
Benjamin Row, Green
Haworth,
Oswaltdtwistle, Lancashire BB5 3RZ.
Tel: 01254 872727/01254 383808
baldwin_r2@sky.com
Social

0241 Preston & DMCC

Stephen Tomlinson, 28 The Crescent,
Clitheroe BB7 2LP. Tel: 07933 436313
ste@prestonmcc.co.uk
stetom12@hotmail.com
www.prestonmcc.co.uk
RR

PDMCC Marshals Club

Julie Jefferies 40 Collingwood
Way, Westthoughton, Bolton, BL5
3TS. Tel: 01942 790488/01942
790488
pdmccmarshalsclub@ntlworld.com
Marshals club & social

0244 Rivington Barnstormers MCC Ltd

Mr David Harrison, 93 Yarrow
Road, Chorley, Lancs PR6 0LU.
Tel: 01257 410448/07905
157444
quizdave@yahoo.co.uk
GT

0245 Rochdale & DMCC

Mrs Margaret Whitlow, 32 Southdown
Close, Sudden, Rochdale, Lancs
OL11 4PP. Tel: 01706 633977
mmlwhitlow@gmail.com
T, t

13 ACU – SOUTH EASTERN

*Area Kent, East Sussex, West Sussex, Surrey and
that part of Greater London south of the River
Thames.*

Chairman

Mr Steve Moore, Bramble Cottage, Church Lane,
Bisley, Surrey, GU24 9EA. Tel: 01483 486320
builderstevemoore@gmail.com

Secretary

ACU Main Office. Tel: 01788 566400
admin@acu.org.uk

Treasurer

Mr Roger Brown, 66 Bramble Rise,
Brighton, BN1 5GF. Tel: 01273 563931
rogerbrown66bramble@gmail.com

Permit Secretary

ACU Main Office. Tel: 01788 566400
admin@acu.org.uk

Trials Recorder

Mr Rob Fleet, 10 Penshurst Road,
Bexleyheath, Kent DA7 5ES. Tel: 01322
446556 robdffleet@gmail.com

Motocross Liaison Officer

Mr John Powell. Tel: 07733
272078 sidcup@ntlworld.com

Grass Track Recorder

Mr Luke Russell, 44 Percy Road, Hastings,
East Sussex, TN35 5AR

lukerussell@live.co.uk Enduro Recorder

Mr Alan Dudley, Suilven, Highlands Road,
Beare Green, Dorking, RH5 4LR. Tel: 01306
710415 alp_fc@yahoo.co.uk

“The Sporting Motorcyclist” production

Mr Andy Wood, 30 Westways,
Edenbridge, Kent, TN8 6AA. Tel: 01732
865380

anmarprintingservices@gmail.com

ACU Benevolent Fund Officer

Mrs. Hazel Collins, 14 Brookside, Calcot,
near Reading, RG 31 7PJ. Tel: 01189
421534 rhaze@talktalk.net

0251 Ashford MCC

Mr Terry Gray, Crossbeck, 18
Northumberland Avenue, Kennington,
Ashford, Kent, TN24 9QG. Tel: 01233
641865 tegra@btconnect.com

T, t

0252 Astra Grasstrack Club

Mrs Elaine Hurry, 83 Walsby Drive, Sittingbourne, Kent, ME10 2TT. Tel: 07500 939122
grahamhurry04@aol.com
GT

0254 Barham DMC & LCC

Mr Mark Ridge, 6 Greenacre, Kingston, Canterbury, Kent CT4 6JF. Tel: 07860 332655 mark.ridge@btinternet.com
www.barhammotorcycleclub.co.uk
T, t

0256 Bexleyheath & DMCC Ltd

Mr Dennis Fleet, 10 Penshurst Road, Bexleyheath, Kent, DA7 5ES.
Tel: 01322 446556
robdffleet@gmail.com
www.motorbiketrial.com
T, t

0804 Bognor Regis & District MCC Ltd

Mr Anthony Martin, Wayside, Post Office Lane, North Mundham, Chichester, West Sussex, PO20 1JY. Tel: 01243 537331
phil.bmplant@gmail.com
T, t

0260 Carshalton MCC

Mr Dan Rose, Comp Shoot, Bechin Wood Lane, Platt, Kent, TN15 8QN. Tel: 07766 143193
dan.rose@centralbikes.co.uk
www.carshaltonmcc.com
SCE, HH, T

0261 Crawley & District MCC

Mr Lawrence Osborne, Flat 87 Cantebury House, 6 Sydenham Road, Croydon, London, CR0 9BL. Tel: 07936 711134
whphch_1982@yahoo.co.uk.
MX

0716 Crowthorne Cycle Trials Club

Mr Graham Charles Tickner, 101 Cottimore Lane, Walton-on-Thames, Surrey KT12 2BU. Tel: 01932 885347
crowthornecycletrials@gmail.com
m ticknerfamily@yahoo.co.uk
www.crowthorne-ct.co.uk
BT, bt, AT, at, T, t

0262 Croydon MCC

Peter Moller, Longview, 2 Slade Lane, Rogate, Petersfield, GU31 5BW. Tel: 01730 818403/01980 050420
petermoller250@gmail.com
www.croydonmotorcycleclub.co
m T, BT, SCE, HH

0263 Dorking & DMS & LCC

Mrs Julian Denmark, 27 Dorking Road, Chilworth, Guildford, GU4 8 NW. Tel: 07831 637865
secretary.ddmc@gmail.com
S

0264 Double Five Kent MC Ltd

Mr Monte Bryant, 67 Vaughan Drive, Kemsley, Sittingbourne, Kent, ME10 2UB. Tel: 07501 858782 monte.bryant@outlook.com
www.doublefive.co.uk
T, t

0265 Eastbourne & DMC LDT

Mr John Crawl, 16 Mount Pleasant, Blackboys, East Sussex, TN22 5LH. Tel: 01825 890499
wimdons@hotmail.co.uk
www.edmcc.co.uk
T, t, LDT

0837 East Kent Schoolboy Scrambles Club Rachel

Gidley, 7 Legatt Road, Eltham, London, SE9 6AB. Tel: 07720 603349
eastkentssc@hotmail.com
MX, mx

0267 Erith & District MCC

Mr Colin Mote, 56 Warren Road, Chelsfield, Kent, BR6 6HY. Tel: 01689 816413 colinmote@gmail.com
T, t

0268 Folkestone MCC

David Fagg, 22 Hasborough Road, Folkestone, CT19 6BQ. Tel: 07983 610585 dave.fagg@gmail.com
www.fincctrials.co.uk
T, t

0269 Frittenden & District MCC Ltd.

Mrs Sandy Russell, 8 Gwyneth Grove, Bexhill-on-Sea, East Sussex, TN40 2SZ. Tel: 01424 730943/07906 510950
sandyrussell@live.co.uk
www.fdmcc.co.uk
GT, gt

0270 GEST (MX) Hastings MCC Ltd.

Madalyn Betsworth. Tel: 07922 749302,
gestsecretary@gmail.com
www.gestmx.co.uk
MX, mx

- 0561 GEST (Trials) Hastings MCC** Mr Paul Chapman, 31 William Road, St Leonards-on-sea, East Sussex TN38 8DE. Tel: 01424 426025 bones.chapman@yahoo.co.uk www.gest-club.co.uk
T, t
- 0679 Goodwood Marshals Club Ltd.** Kirk Elleker, 3 Downview Close, Mid Lavant, Chichester, West Sussex, PO18 0BZ. Tel: 01243 539714 k.elleker10@yahoo.co.uk www.goodwoodmarshalsclub.org.uk
S, HC
- 0271 GTSA Racing Ltd.** Lydia Penfold, 14 Spinks Court, Somerley Road, Forgewood, Crawley, RH10 3SY. Tel: 07746 134309 lspenfold@hotmail.co.uk
GT
- 0272 Gravesend Eagles MC & MCC Ltd.** Mr John Pattinson, 27 Hadley Close, Meopham, Gravesend, Kent, DA13 0NX. Tel: 01474 813239 john.pattinson80@gmail.com www.gravesendeaglesmc.co.uk
T
- 0273 Greenwich MC & MCC** Mrs Geraldine Claridge, 32b Elm Grove, Peckham, London, SE15 5DE. Tel: 020 7732 1129 johnandgerry@gerny.co.uk www.greenwichmotorcycleclub.co.uk
Social
- 0274 Haslemere MCC** Mr John Sapsard, 13 Windsor Road, Lindford, Bordon, Hants, GU35 0RY. Tel: 01420 473687 john.sapsard@btinternet.com www.haslemeremcc.co.uk
T, t
- 0713 Hookwood Trials Club** Mr Jim Connor, Hookwood Manor, Fullers Farm Road, West Horsley, Surrey, KT24 6ET. Tel: 01483 285727 jimconnor1045@yahoo.com
T, t, BT, AT
- 0275 Horsham & DMCC** Mrs Myra Hayden, 1 Inglenook, Andrews Road, Southwater, Horsham, W Sussex, RH13 9EU. Tel: 01403 732124/07775 743242 myra.hayden@outlook.com www.hdmcc.co.uk
T, t
- 0646 Invicta Track Racing Club** Mr Mitchel Godden, 6 Green Lane, Collier Street, Marden, Tonbridge, TN12 9RE. Tel: 01892 730292 msgoddon@hotmail.com
GT, gt, LT, lt, ST, QGT
- 0277 Kent & Sussex MCC** Mr Jon Sturdey, Sturdey Motorcycles Ltd, 94c Shipbourne Road, Tonbridge, Kent, TN10 3EG. Tel: 01732 354082 kentandsussexmcc@gmail.com
T, t
- 0645 Kent Youth Grass Track Riders Association** Ms Barbara Durand, 87 Westgate Close, Canterbury, Kent, CT2 8JH. Tel: 07717 111772/07954 150811 theoldgunsite@gmail.com
GT, gt
- 0280 Kent Youth Trials Club Ltd.** Michele Baldock, Fairview Farmhouse, Ruckinge, Ashford, Kent, TN26 2NT. Tel: 01233 730891/07879 697792 kytctrials@yahoo.com www.kytc.co.uk
T, t
- 0281 Kingston & DMCC Ltd** Mr. Ted Smith, 19 Fairmead, 9 Epsom Road, Leatherhead, Surrey, KT22 8ST, SM4 6DF. Tel: 01372 375708 e.smith79@btinternet.com www.kdmcc.com
T, t, SCE
- 0285 Maidstone Aces MCC** Mr Chris Downs, 38 Maidstone Road, Paddock Wood, Tonbridge, Kent TN12 6BT. Tel: 07413 883063 secretary@maidstoneaces.com
GT
- 0751 Mid Sussex MCC** Simone Laughton. Tel: 07912 516729 secretary@msmxc.co.uk
MX, mx

0286 Metropolitan Police Motor Club

Mr Stuart Brogan
 sjbrogan@hotmail.co.uk
 www.metpolicemotorclub.com
RR, BT, E, HH, RAL

0288 Normandy MCC Ltd

Mr Richard Thomas, 46
 Rowtown, Addlestone, Surrey,
 KT15 1HQ. Tel: 01932
 889311/07889 142827
 rhwandjc.thomas@ntlworld.com
 www.normandymcc.co.uk
T, t, SCE, sce, HH, hh

0289 OWLS Motor Club Ltd.

Peter Sharman, Silvester
 House, Gravesend Road,
 Shorne, Kent, DA12 3JH. Tel:
 01474 823833
 peter.sharman48@btinternet.com
T, t

0291 Reigate Redhill & North Downs MCC

Mr Richard Coles, 24 Braes Mead,
 South Nuffield, Surrey, RH1 4JR.
 Tel: 01737 822312
 diccles221@gmail.com
 www.rrnd.co.uk
T, t

0294 Sidcup & DMCC Ltd.

Mrs Marge Clarke, 12 Sarsen
 Heights, Walderslade, Chatham,
 Kent, ME5 9HW. Tel: 01634
 201268
 margeclarke45@gmail.com
 www.sidcupmotorcycleclub.co.uk
MX, T, t, LDT, SCE, HH

0295 Sittingbourne & DMCC Ltd

Mr Roy Piles, 5 The Bungalows,
 Brogdale Road, Faversham,
 Kent, ME13 8XY. Tel: 01795
 537162
 roy.piles@mypostoffice.co.uk www.
 sittingbourneanddistrictmotorcycleclu
 b.co.uk
T, t

**0786 Sittingbourne & Iwade Track Racing
 Association**

Mr Paul Standing, Caravan 1,
 Ranagreg, Bell Farm Lane,
 Minster,
 Kent ME12 4JB. Tel: 07802 795000
 paulvmcc2@hotmail.com
 www.sitrauk.org
GT, gt, QGT, ST

0299 Southern Sporting MCC

Mr Ian Slater, 16 Raleigh Way,
 Hanworth Park, Feltham, Middlesex,
 TW13 7NX. Tel: 08432891381
 enquiries@ssmcc.co.uk
 www.ssmcc.co.uk
T, RR

0577 Sporting Elite MCC

Mr Stephen Barley, 18 Manor Way,
 Mitcham, Surrey, CR4 1EE. Tel: 020 8764
 6664/07808 810140
 barleyallan@aol.com *MX, Social*

0301 Sunbeam MCC Ltd

Paul Bullock. Tel: 07973
 123360 secretary@sunbeam-
 mcc.co.uk www.sunbeam-
 mcc.co.uk
T, Social, Vintage

0302 Surrey Constabulary MCC

James Brown, Rake Hill Cottage, Primrose
 Lane, Liss, Hants, GU33 7PJ. Tel: 07411
 364803 www.scmcc.moonfruit.com
T, t, SCE, HH

0303 Surrey Schoolboy Trials Club

Caroline Boys-Guest, 24 Hitchings
 Way, Reigate, Surrey, RH2 8EW.
 Tel: 07946 333326
 ck.boysguest@sky.com
 www.surreysbtrials.org
T, t

0305 Talmag MCC

Mr Ian Allaway, 43 The Street,
 Wrecclesham, Farnham, Surrey,
 GU10 4QS. Tel: 01252 718606.
 ian@jamsport.co.uk
T, t

0306 Tenterden & DMC Ltd.

Mr. Dave Luck, 9 Sherwood Close,
 Herne Bay, Kent, CT6 7DX. Tel: 07912
 512994 david@ducron.co.uk
 www.tenterdenmcc.co.uk
T, t

0307 Thames MCC

Mr Bob Brown, 79 Long Lane, Ickenham,
 Middlesex, UB10 8QS. Tel: 01895
 638738 robertbrown222@hotmail.com
 www.thamesmcc.org
T, t

0309 Tongham Tigers Sports MCC

Mr Brian Foster, 20 Robin
 Lane, Sandhurst, Berkshire,
 GU47 9AU. Tel: 07732
 191967
 bfoster_20@yahoo.co.uk
 www.tonghamtigers.co.uk
k T, t

0311 Twickenham & DMC Ltd.

Mrs E Argent, 137/139 Hook Road,
 Surbiton, Surrey, KT6 5AR. Tel: 0208
 3974876 motoriteracing@btconnect.com
MX, T

0313 Wickham MCC

Mr Robert Bond, Summer
Meadow, Wilderness Avenue,
Sevenoaks, Kent, TN15 0EB. Tel:
0203 946 1123
paceo@rydon.co.uk
T, t

0315 Witley & DMCC

Mr Tristan Robinson, Wayback,
Greenway, Sherfield on Lodden, Hook,
Hampshire, RG27 0EE. Tel: 07817
2131821 www.witleymcc.org
T, t, LDT, AT, at, E, e, SCE, sce, HH, RAL

GROUPS**0316 East Kent Trials Combine**

T, t

0319 North Kent Trials Combine

Mr Aaron Seamer,
Timberscombe, Stendiff,
Cooling, Rochester, Kent, ME3
8DD. Tel: 01634 221587
aaron.seamer@tiscali.co.uk
www.nktctrial.com
T, t

0320 South Eastern Enduro Combine

Mr Carl Boraman, 3 Neville Close,
Binfield, Bracknell, Berkshire, RG42
4AZ. Tel: 07789 777777
www.seecenduro.co.uk E, SCE

0321 South Eastern Grass Track Combine Mr

Andy Wood, 30 Westways,
Edenbridge, Kent, TN8 6AA. Tel:
01732 865380
anmar_uk@yahoo.co.uk
GT

0322 South Eastern Moto Cross Combine

Mrs Marge Clarke, 12 Sarsen
Heights, Walderslade, Chatham,
Kent, ME5 9HW. Tel: 01634
201268 margeclarke45@gmail.com
www.mxsoutheast.co.uk
MX

0323 South East Trials Combine

Mr Rob Fleet, 10 Penschurst Road,
Bexleyheath, Kent, DA7 5ES. Tel: 01322
446556 robdfleet@gmail.com
www.setrials.co.uk
T, t

0324 Star Group

John Sapsard, 13 Windsor Road,
Lindford, Bordon, Hants. GU35 0RY. Tel:
01420 473687
john.sapsard@btinternet.com
T, t

0325 Thames Valley Trials Combine Mr

Richard Thomas, 46 Rowtown,
Addlestone, Surrey, KT15 1HQ.
Tel: 01932 889311/07889
142827
rhwandjc.thomas@ntlworld.com
www.thamesvalleytrials.co.uk
T, t

14 ACU – SOUTHERN

*Area Hampshire, Isle of Wight, Dorset, Channel
Islands, that part of Wiltshire south of a line
east/ west through Trowbridge, that part of
Berkshire situated south of the River Thames,
that part of Oxfordshire south of the River
Thames.*

Secretary

Mr C. H. Fletcher, 1 Fairclose,
Whitchurch, Hampshire RG28 7AN. Tel:
01256 242214 chris-
fletcher@tiscali.co.uk

President

Mr B. New, 6 Coleridge Gardens, Cowplain,
Waterlooville, Hampshire, PO8 8LJ. Tel:
02392 645114

Chairman

Mr R Hewson, 12 Greenfield Crescent,
Waterlooville, Hants, PO8 9EH. Tel:
02392 592919

franandrob46@hotmail.co.uk **Treasurer**

Mr Shane Babey, "Cuffnells", Salisbury
Road, Plaitford, Romsey, Hampshire, SO51
6EE. Tel: 07591 502977
shane_babey@yahoo.com **Rights of Way
Officer**

Mr M Down, 18 Barcelona Close, Andover,
Hampshire, SP10 1LQ. Tel: 01264 366425
martindown1@gmail.com

Grass Track Recorder

Mrs D. Read, 12 Heights Road, Upton,
Poole, Dorset BH16 5QL. Tel: 01202
778136 phoenix57@ntlworld.com

Motocross Recorder

Mrs M Slater, 7 Orchard Avenue, Bishopstoke,
Eastleigh, Hants, SO50 8HN. Tel: 02380 695325
marrolls@aol.com

Trials Recorder

Mr M Wiseman, 27 Foxhayes Lane, Mopley,
Southampton, Hants, SO45 1XX. Tel: 07533
741177 walthamchasetrials@outlook.com

Enduro Recorder

Mr Shane Babey, "Cuffnells", Salisbury
Road, Plaitford, Romsey, Hampshire, SO51
6EE. Tel: 07591 502977
shane_babey@yahoo.com

Permit Secretary

Miss C. Ballard, 26 Droxford Crescent, Tadley, Hampshire RG26 3BA. Tel/Fax: 0118 981 2595 ballardclaire@hotmail.com

Benevolent Fund Officer

Mr T. D. Graves, 13 Locksley Road, Eastleigh, Hampshire, SO50 5DX. Tel: 02380 643503/07586 807927

The Sporting Motorcyclist Editor

Mr J. Bramall, 16 Gifford Close, Fareham, Hants PO15 6PJ. Tel: 01329 823282

johnbramall246@btinternet.com

0326 Aldermaston Nomads MCC

Mr Ian Mace, 1 Yew Close, Kingsclere, Newbury, Berks, RG20 5ET. Tel: 07771 774978
ianmace@gmail.com
www.aldermaston-nomads.org
T, t

0327 Alton & District MC & CC

Mrs Kerry Henderson, 18 Lionsfield, Oakhanger, Bordon, Hampshire GU35 9LA. Tel: 01420 474470
jaynkez@aol.com
www.willbrown.co.uk/alt
T, t

0329 Basingstoke MCC

Mr Peter White, 58 Long Barn Lane, Reading, Berkshire RG2 7SX www.basingstokemcc.co.uk
MX, QMX, GT, QGT, T, t, RAL, Social

0330 Blackmore Vale MCC

Mr Dean Whitty, 17 Alcocks Crest, Warminster, Wilts, BA12 8ND. Tel: 07518 810197 whittydean@gmail.com
T, t

0331 Bridport & Weymouth MCC

Mr Ivan Rose, 14 Frome View, Maiden Newton, Dorchester, Dorset. DT2 0BU. Tel: 01300 320063
icrose014@gmail.com
www.bridportandweymouthmcc.co.uk
k, t

0587 Classic Vintage & Modern Motor Racing Club of Jersey

Mrs Mandie Glendewar, 132 Clos des Sables, Route Orange, St Brelade, Jersey, JE3 8JH. Tel: 01534 483154/07797 738187
mandie_stuart@hotmail.com
www.classicandvintagejersey.co.uk
k
S, HC

0328 Danebury Grasstrack Racing Club

Miss Rachel Mothersole, 10 Millway Close, Andover, Hampshire, SP10 3AX. Tel: 07854 836663
daneburygtrc@hotmail.co.uk
GT, gt, QGT

0336 Farnham & DMCC

Mr Alan Silvester, 'Redhearne', Old Kiln Lane, Churt, Farnham, Surrey GU10 2HX. Tel: 01428 714034
alanjenny@redhearne.plus.com
T

0338 Guernsey Kart & Motor Club

Mrs Heather Robilliard, "A'JAMAIS" 6 Hougues Magues Lane, Cappelles, St Sampsons, Guernsey GY2 4WA. Tel: 01481 247892
hr52@suremail.gg www.gkmc.co.uk
SP, HC, MX, mx

0339 Guernsey Motor Cycle & Car Club

Mrs Sandra Le Page, 'Falstria' Beaulieu Crescent, Route Militaire, St Sampson, Guernsey, GY2 4EA. Tel: 01481 241248
gmcccsecretary@cwgsy.net
www.gmccc.co.uk
HC, GT, gt, SR, sr, T, t

0341 Isle of Wight MCC Ltd

Mrs Rachael Brodie, 45 Castle Road, Newport, Isle of Wight, PO30 1DT. Tel: 01983 523264
waynebrodie77@gmail.com
www.iowmcc.co.uk
MB, mb, T, t, AT, at

0342 Jersey MC & LCC

Mrs Carol Le Viellez, 'The Chequered Flag', Rue de Charrieres, Trinity, Jersey JE3 5AS. Tel: 01534 852952
secretary@jerseymotorsport.com
www.jerseymotorsport.com
S, HC, MX, mx, GT, gt, SR, sr, T, t

0811 Kiwi MCC

Mr Alan Ranger, Rangers Garage Ltd, 1 Bulford Road, Durrington, Wilts, SP4 8DL. Tel: 01980 655555/07711 306306
admin@rangersgarage.co.uk
E, HH, T

0584 Langrish Motor Cycle Racing Club
Chris Warren, 39 Walburton Way,
Clanfield, Hampshire, PO8 0XP.
Tel/ Fax: 01730 894241/07809
443132

wgconsultants@hotmail.co.uk
MX, mx

0343 Lymington Motor Cycle & Light Car Club Ltd

Mr Geoffrey Price, 2 Havelock
Way, Christchurch, Dorset
BH23 4PA. Tel: 01425
270418
lmclcltd36@yahoo.co.uk
www.lymingtonmotorcycle.co.uk
RAL, SRAL, Social

0638 Moonfleet Grasstrack Club

Mrs Sally Croft, 32a Holloway Road,
Fordington, Dorchester, Dorset DT1
1LF. Tel: 01305 268367
adrian.croft@ymail.com *GT, gt*

0346 Mortimer MCC Ltd

Mr Mark Boshier, 154
Westwood Road, Tilehurst,
Reading, Berkshire RG3 6LL.
Tel: 01189 426231
aboshier@btinternet.com
www.mortimerclassicmcc.com
MX, T

0347 North Berks. MCC

Ms Claire Maynard-Robinson, The
Chapel, 14 Blewbury Road, East
Hagbourne, Oxon, OX11 9LF. Tel:
01235 816644
northberksmcc@gmail.com
www.northberksmcc.com
T, t, AT

0351 Off Road Motorcycling Club

Mr Colin Boniface, 44
Southampton Street, Farnborough,
Hants,
GU14 6BG. Tel: 07734 905750
admin@offroadmotorcycling.org.uk
www.offroadmotorcycling.org.uk
T, t, BT, bt, AT, at, QT, qt, E, SCE, HH

0348 Portsmouth Motor Cycle Racing Club Ltd

Shane Babey "Cuffnells", Salisbury
Road, Plaitford, Romsey, Hampshire,
SO51 6EE. Tel: 07591 502977
shane_babey@yahoo.com
www.pmcrc.org
HH

0462 RAF Odiham MCC

Mr Ian Davidson, 3 Waterloo Close,
Camberely, Surrey, GU15 1PY. Tel:
07952 173703 acu@omcc.co.uk
www.omcc.co.uk *RAL*

0352 Ringwood MC & LCC

Mr Tony Chalk, Orchard House, Boldre
Lane, Boldre, Lymington, Hants,
SO41 8PA. Tel: 01590 674833/077897
10676
tony.chalk@btinternet.com
www.ringwood-mc-lcc-co.uk
T, t

0718 Rogershill Off Road Events

Miss Emily Hall, Rogershill
Farm, Briants Puddle,
Dorchester, Dorset DT2 7HJ
(postcode for SatNav DT2 7HN)
Tel: 07551
007880
jhallandsons@yahoo.com
www.rogershillraceway.co.uk
E, HH

0353 Salisbury MC & LCC

Mr Martin Fildes, 81 Bulbridge Road,
Wilton, Wilts, SP2 0LE. Tel: 07511
617684/01722 744076. secretary@
salisburymotorcycleandlightcarclub.co.
uk
www.salisburymotorcycleandlightcarclub.
co.uk
T, LDT, Social

0354 Southampton & District MCC

Mrs Amanda Grattan, 20
Stalybridge Close, Park Gate,
Southampton, Hants SO31 7FZ. Tel:
07496 021058
secretarysdmcc@hotmail.com
www.sdmcc.net
T

0356 Southern Centre Grass Track Riders Association

Mr Phil Spencer, 22 Hounsdown Ave,
Totton, Southampton, Hampshire.
SO40 9EX. Tel: 02380 572419/07880
554291
phil@ptspencer.freeuk.com
GT, gt

0358 Southern England Trail Riders Association

Mr Paul Armstrong, 31 Robbins
Ridge, Amesbury, Wilts, SP4 7RF.
Tel: 07836 600900. office@cherry-
estates.co.uk *HH, SCE*

0360 South Hants. Scramble Club

Miss Lisa Harris, 24 Tongham Road,
Aldershot, Hampshire. GU12 4AA.
Tel: 07519 784792
shsc@hotmail.co.uk MX

0362 Tadley Sporting MCC

Mr Brice Haines, Two Oaks,
Summerlug, Mortimer, Reading,
Berkshire RG7 2JS. Tel: 01189
333145 anneandbrice@yahoo.com
T, Social

0345 Track n Trail Ltd

Mr Michael Grounds, Unit 13A Mill
Lane Precinct, Mill Lane, Wimborne,
Dorset, BH21 1JQ. Tel: 01202
600675/07581
143212 office@trackntrail.co.uk
www.trackntrail.co.uk
E, SCE, HH

0607 Vectis Isle Pioneers MCC

Mrs Christine Jacobs, 4 Spring
Walk, Newport, Isle of Wight
PO30. Tel: 01983 521730/07817
830557 vipmcc@hotmail.co.uk
www.vipmcc.org.uk
T, t

0364 Waltham Chase MCC

Mr Mike Wiseman, 27 Foxhayes Lane,
Mopley, Southampton, Hampshire
SO45 1XX. Tel: 02381 781423/07533
741177
walthamchasetrials@outlook.com
www.walthamchasetrials.co.uk
T, t

0366 Waterlooville MCC

Mrs Sue Cox. The Old Thatched
Cottage, 203 Lovedean lane,
Waterlooville,
Hants. PO8 9RT. Tel: 02392 593004
wmcc:secretary@hotmail.co.uk
www.waterloovillemotorcycleclub.co.
uk MB, GT, T, E, RAL, Social

0367 Waterside MCC

Miss Jo Clark, 'Little Warren',
Harrow Wood Farm, Poplar Lane,
Bransgore, Hampshire, BH25 8JE.
Tel: 07733 366481
watersidejmcc@yahoo.co.uk
www.watersidejmcc.org.uk
T, t

0369 Wimborne MCC

Mr Christopher Maidment, 8 St.
John's Hill, Wimborne, Dorset
BH21 1DA. Tel: 01202 885103
deanna.maidment@sky.co
m
www.wimbornemcc.co.uk
GT, gt

0370 Winchester MCC

Mr David Hamer. Tel: 07867 635745
winchestermcc@hotmail.co.uk
www.thewinchestermotorcycleclub.co.u
k MX

0371 XHG Tiger MCC Ltd

Mr Jonathan Hayhurst. Tel: 07973
271217 j@hayhurst.co.uk
www.xhgtiger.org.uk
T, t, HH, SCE

15 ACU – SOUTH MIDLAND

*Area Northamptonshire, that part of
Oxfordshire situated north of the River
Thames, Buckinghamshire, Bedfordshire,
Cambridgeshire,
Hertfordshire, that part of Greater London
situated north of the River Thames and west of
the River Lea, that part of Berkshire situated
north of the River Thames.*

Secretary

Mr Terry Golds, 21, Buckingham Drive, Luton,
Beds. LU2 9RA. Tel: 01582 455714 Mob: 07747
855264 terrygold@ntlworld.com

President

Mrs J Ayers, 32 Station Road, Irchester,
Wellingborough, Northants, NN29 7EN.
Tel: 01933 316745
judithayers@btinternet.com

President Emeritus

Mr Colin Moram, 'Garonne', Hay Lane,
Fulmer, Bucks, SL3 6HJ.
colinmoram66@gmail.com **Chairman**
Mr John Coles, 88 Wheatley Road, Garsington,
Oxon OX44 9DR. Tel: 01865 361735
jfcoces88@gmail.com

Treasurer

John Harding, 8 Muriel Close, Papworth
Everard, Cambridge, CB23 3UJ.
Tel: 01480 830079 Mobile: 077425 11993
johnaharding@msn.com

Grass Track Recorder

Mr D. Porter, 22 Belper Road, Luton, Beds LU4
8RG. Tel: 01582 651189 Mob: 07710 435127
david.porter31@btinternet.com

Motocross Recorder

Miss M Bird. Tel: 07773 064796

mellie.bird@ntlworld.com

Trials Recorder

Mrs Karen Southwood. Tel: 01525 3838538.
karensouthwood51@gmail.com

Competition/Permit Secretary

Mr Ian Reynolds, 186 Regal Way,
Harrow, Middx, HA3 0SQ. Tel: 0208 907
9856

reynolds.russell@virgin.net

Steward Co-ordinator

Mr Roy Watson, 26 Cornwall Court, Eaton
Socon, St Neots, Cambs, PE19 8PR Mob:
07789 222121 roy.watson3@ntlworld.com

Rights of Way Officer

Mr C. Hurworth, 23 Cambridge Crescent,
Totteridge, High Wycombe, Bucks HP13 7NE.
Tel: 01494 446198

Benevolent Fund Officer

Mr D. Porter, 22 Belper Road, Luton, Beds LU4
8RG. Tel: 01582 651189 Mob: 07710 435127
david.porter31@btinternet.com

0374 Barnet & DMCC

Mr D J Jordan, 1 Roseacre Villas
Bedmond Road, Pimlico, Hemel
Hempstead, Herts, HP3 8SG. Tel: 01923
264156 Mob: 07711
423314 davidjordan365@outlook.com
T, t

0375 Berkhamsted MCC

Lionel Cox. Tel: 07817
444989
offroadtrails@btconnect.co
m *T, t*

0376 Cambridge Centaur MCC

Mr Mark Clack, 5 Spurgeons
Avenue, Waterbeach,
Cambridge CB25 9NU. Tel:
01223 512809
centaur.mcc@ntlworld.com
Social

0378 Cambridge Matchless MCC

Mr Colin Nunn, 42 Old School Lane,
Milton, Cambridge CB24 6BS. Tel:
01223 860829
margaretnunn@btinternet.com
www.cambridgematchless.co.uk
T, t

0381 Dunstable & DMCC

Mrs M. Martin, 33 Pondfield Crescent,
St. Albans, Herts AL4 9PE.

0382 Farnham Royal MC & LCC

Mr Mick Vockins, 6 Pipers Close,
Burnham, Bucks. SL1 8AW. Tel:
01628 661791 m.cv1@hotmail.com
RR, T, Social

0610 Fenland Grass Track Club

Mr Ray Parcell, 12 Hall Close, Bourn,
Cambridgeshire, CB23 2SW. Tel:
01954 718610.
vandaparcell@gmail.com
www.fenlandgtc.org.uk
GT, gt

0384 Hayes & Southall MCC

Mr Colin Sweby, Sunyani, Send Marsh
Road, Ripley, Surrey GU23 6JQ. Tel:
01483 225423 csweby@outlook.com
GT, T, Motoball

0717 Heart of England Motorcycle Club

Mrs Mellisa Cossar. Tel: 01788 566402

0386 Hillingdon & Uxbridge MCC

Mr Barry Bannister. Tel: 077719 75131.
post@hux.org.uk www.hux.org.uk
T, t

0658 Kensworth Schoolboy Motocross Club

Mr Steve Wilkinson, 43 Loring Road,
Dunstable, Beds. LU6 1EA. Tel:
01582 696231.
stevewilkinson01@aol.com *MX, mx*

0387 Kenton & Kingsbury MCC Mr

Dean Devereux, 20 Hall
Avenue, Rushden,
Northants, NN10 9ET. Tel:
01933 318992
dean.devereux@ntlworld.com
T

0388 Luton & DMCC Ltd

Melanie Bird. Tel: 07983 869753
secretary@lutonanddistrictmcc.
om
www.lutonanddistrictmcc.com
MX, T

0391 Milton Buzzard MCC

Mr Dave Giltrow,
info@miltonbuzzard.com
www.miltonbuzzard.co.uk
k T, t

0393 Nene Valley MCC Ltd

Mr Roy Watson, 26 Cornwall
Court, Eaton Socon, St. Neots,
Cambs PE19 8PR. Tel: 01480
393481/07789
222121 roy.watson3@ntlworld.com
www.nenevalleytrials.co.uk
T, t

0394 Northampton MCC Ltd

Mrs Marjorie Hemmings, 31 Rea Close, East Hunsbury, Northampton NN4 0RE. Tel: 01604 768812
marjoriwhemmings@gmail.com
www.nmcc.co.uk
MX

0396 North East London MCC

Mr Roy Phypers, 51 Woodland Road, Hertford Heath, Herts SG13 7QW. Tel: 01992 582408
roy.phypers@ntlworld.com
www.northeastlondonmcc.org.uk
T, t

0397 Oxford Ixion MCC Ltd

Mr Gordon Faulkner, 153 Godstow Road, Wolvercote, Oxford, OX2 8PG. Tel: 07768 013776
faulkners2003@hotmail.com
T, t

0399 Peterborough Junior MX Club Laura

Curl, 38 Ragdale Close, Peterborough, PE1 4XA. Tel: 07504 686903,
pjmcsec@gmail.com
mx

0650 RAF Benson Motorcycle Club

Mr Jonathan Snell, P2MF Structures Bay, RAF Benson, Wallingford, Oxon OX10 6AA. Tel: 01950 617438
j.snell789@btinternet.com

0402 South Harrow & DMCC

Mr Bob Brown, Keppel Gate, 79 Long Lane, Ickenham, Middlesex, UB10 8QS. Tel: 01895 638738
robertbrown222@hotmail.com
T, t, MB

0403 South Reading MCC

webmaster@srmcc.co.uk
www.smcc.co.uk www.srmcc.co.uk
T, HH

0405 Stevenage & DMCC

Mr Mick Taylor, 17 North Road, Stevenage, Herts SG1 4BD. Tel: 01438 354130
taylor.mick40@yahoo.com
www.stevenageanddmcc.co.uk
S, RR, Social

0733 Stowe School MCC

Mr Patrick Gilson, 36 Buckingham Road, Winslow, Bucks. MK18 3DY. Tel: 07763 244725
pgilson@gmail.com

0407 West Middlesex Amateur MCC

Mr Malcolm White, 3 Nash Park, Bracknell, Berkshire, RG42 4EN. Tel: 01344 642866
westmiddlesexamateur@gmail.com
T, t

0409 Wycombe & District MCC Ltd

Mr John Eckhart. Tel: 01628 473509
wycombetrials46@hotmail.co.uk
www.wycombemcc.com
T, t

GROUPs

0410 Meteor Group

Mr R. Twigg, 2 Harwood Close, Welwyn Garden City, Herts AL8 7SN. Tel: 01707 880244
bobtwigg@ntlworld.com
T, t

16 ACU – SOUTH WESTERN

Area Devon, that part of Somerset situated south of the line made up from map reference ST29350, eastwards to ST360520, southwards to ST360470, eastwards to ST48041, southwards to ST480380, eastwards to ST880350 (the Somerset/Wiltshire County boundary).

President

Mrs G. Edwards, Courtfield, Ashill, Cullompton, Devon EX15 3NH. Tel: 01884 840078

Chairman

Mr A Pearce, 20 Courtlands Road, Tavistock, Devon, PL19 0EF. Tel: 07899 917005
adp01235@googlemail.com

Secretary

Miss K. Coffin, Clennon Brake, Blagdon Road, Paignton, Devon TQ3 3YB. Tel: 07835 451277
kailee@westofenglandmc.co.uk

Treasurer

Mr S Grinter, 29 Farm View, Taunton TA2 7QY. Tel: 07887 408429
taunton_mcc@yahoo.co.uk

Publication Editor

Mr A. Bramwell, 3 Stokehouse Street, Poundbury, Dorchester, DT1 3GP. Tel: 07729 759982
andy.bramwell@hotmail.co.uk

Permit Issuing Officer

Mr A Pearce, 20 Courtlands Road, Tavistock, Devon, PL19 0EF. Tel: 07899 917005
adp01235@googlemail.com

Benevolent Fund Officer

Mr C. Pattison, 6 Churchfields, Wincanton, Somerset BA9 9AJ. Tel: 01963 33001

- 0411 Bridgwater & District Motor Club Ltd** Mr Christopher Carter, 37 Bristol Road, Bridgwater, Somerset TA6 4AU. Tel: 07768 536930 ccarter7@sky.com
GT, gt
- 0412 Broadhembury Motor Club** Mrs Greta Edwards, Courtfield, Ashill, Cullompton, Devon EX15 3NH. Tel: 01884 840078
greta.premier@tiscali.co.uk
MX, T, t
- 0674 Dartmoor MCC**
Mr Gary Reece, 16 Lavinia Drive, Plympton, Plymouth, PL7 1ZG. Tel: 077533 60972
garyreece5@hotmail.com
- 0784 Devonport & District Motor Club**
Mr Simon Thornhill, 20 Madden Road, Plymouth, Devon, PL1 4NE. Tel: 01752 568874, siandglo@gmail.com
- 0415 Exmoor MC Ltd**
Mr Melvin Sully, Chetsford, Hopcott Road, Minehead, TA24 5SU. Tel: 01643 821896/01643 707252 Fax: 01643 821140
masully55@yahoo.co.uk
T, t, LDT, E, HH
- 0549 Landrake Moto Club**
Mr Philip Congdon, New Barton, West Lane, Landrake, Saltash, Cornwall PL12 5EP. Tel: 01752 851504/07970 099970
www.landrakemotoparc.com
MX
- 0417 Lyn & DMC**
Mrs Heidi Baker, Ridgeview, Scoresdown, Lynton, North Devon EX35 6LJ. Tel: 01598 752640
heidi.signs@btinternet.com
T, t
- 0418 Minehead Motor Club Ltd**
Mr R. Williams, 5 King Edward Road, Minehead, Somerset.
LDT
- 0419 Moretonhampstead & DMC**
Mr Roger Barnes, 22 Chestnut Drive, Kingsteighton, Newton Abbott, Devon TQ12 3SZ. Tel: 07436 077394
roger.barnesrjb@gmail.com, www.moretontrials.co.uk
T, t
- 0516 National Hill Climb Association Ltd** Mr Peter Isaac, 205a Berrow Road, Burnham on Sea, Somerset TA8 2JG. Tel: 01278 786377
pgisaac@tiscali.co.uk
www.nhca.co.uk
HC, hc
- 0421 North Devon Motor Club** Mick Whitehouse, Woodlands, Lydacott, Barnstaple, EX31 3QG. Tel: 01271 860950/07747 000068
mickw0@btinternet.com
www.ndmc.org.uk
LDT
- 0422 Otter Vale Motorcycle Club**
Mr Colin Somers, 4 Moorland Road, Bournemouth, Dorset BH1 3ST.
Tel: 01202 396628/01202 294621
T, t
- 0649 Somerset Advanced Motorcyclists** Mr Peter Herridge, 5 St James's Park, Yeovil, Somerset BA20 2EX. Tel: 07866 723128/01935 477498 Fax: 08712 472083
peterherridge@netscape.net www.somersetadvancedmotorcyclists.org.uk
k RAL
- 0423 Somerton & DMC & LCC**
Emily Boulton, 5 Moor Lane, Wincanton, Somerset BA9 9EJ. Tel: 01963 34833
emilyboulton87@gmail.com
GT, gt, T, t
- 0672 South Hams MCC**
Mark Newitt, 38 Ernesettle Green, Plymouth, Devon PL5 2SU. Tel: 07814 544265 fullmarks@gmail.com
MX, mx
- 0424 South West Classic Trials Association**
Bob Hill, Church Farm, School Lane, Draycott, Cheddar, BS27 3SD. Tel: 01934 743341 bobhill@live.co.uk
T
- 0676 South West Devon MCC**
Louise Jones. Tel: 07530 627728
loulou8179@hotmail.co.uk
www.swormx.co.uk
- 0088 Tamar Valley MCC**
Mel Martin, 7 Broadway Road, Kingsteignton, Newton Abbot, TQ12 3EH mdmartin@gmx.co.uk

0426 Taunton MCC Ltd

Neil Radford, 15 Upcot Crescent,
Taunton, Somerset, TA1 5JP. Tel: 07809
485799
neilradford60@gmail.com
T, t, LDT, HH

0675 Teignbridge MotoX Club

Richard Miller. Tel: 07554 423742
richmiller14@hotmail.co.uk
www.swormx.co.uk

0427 Tiverton Motor Club

Angie Hill, Wills Barn, Upham, Cheriton
Fitzpaine, Crediton, Devon, EX17 4HW.
Tel: 07967 432052
T, t

0428 Torridge & DMC Ltd

Mrs Helen Soby, Pitt Farm,
Bableigh, Landkey, Barnstaple,
Devon, EX32 0NT. Tel: 07733
300769
helensoby@hotmail.co.uk
www.torridge-
districtmcc.co.uk *T*

0684 Torbay Motor Club

Mr Rodger Harvey, Torbay Motor
Club, 154 Duchy Drive, Preston,
Paignton, Devon, TQ3 1EW. Tel:
01803 522752,
rodgerharvey@blueyonder.co.uk
www.torbaymotorclub.co.uk

0586 West Country Sidecar Association

Mr Andy Cheeseman, 30 Mincinglake
Road, Stoke Hill, Exeter, Devon EX4
7DZ. Tel: 01626 366084/01392
216624
T

0823 West Devon Motorcycle Club

Di Thompson, Sunnycote, Mary Tavy,
Tavistock, Devon, PL19 9QB. Tel: 01822
810336 dithompson15@gmail.com
MX, T, E

0429 West of England Motor Club

Miss Kailee Coffin, Clennon
Brake, Baldon Road, Paignton
TQ3 3YB. Tel: 07835 451277
kailee@westofenglandmc.co.uk
www.westofenglandmc.co.uk
MX, T, LDT, BT, bt, E, HH

0451 Wyvern Moto Club

Mr Adrian Croft, 32a Holloway Road,
Fordington, Dorchester, Dorset DT1
1LF. Tel: 01305 268367/07817
019141
sally.adrian@bushinternet.com
GT, gt

0431 Yeo Vale MCC Ltd

Mr Marcel Perrett, 7 Court Acres, Stoford,
Yeovil, Somerset BA22 9UJ. Tel: 01935
420614 yeovalesec@yahoo.co.uk
www.yeovalemcc.co.uk
T, t

17 ACU – WESSEX

Area *The part of Somerset situated north of a
line from map reference ST293520, eastwards
to*

*ST360520, southwards to ST360470, eastwards
to ST480470, southwards to ST480380,
eastwards*

*to ST770380 (The Somerset/Wiltshire county
boundaries) that part of Wiltshire situated
north of a line east/west through Trowbridge,
part of Gloucestershire situated south of a line
east/west through Dursley.*

Secretary

Mr S. Talbot, Manet, 5 Chestnut Road,
Sutton Benger, Chippenham SN15 4RP. Tel:
01249 720342
talbot.family1@btopenworld.com
www.wessex-centre-acu.org.uk

Chairman

Mr K. Wooster, 59 Oxford Road, Stratton,
Swindon, Wilts SN3 4JB. Tel: 01793
825638/07736 010064

keith@wooster.me.uk **Police Liaison
Officer**

Mrs T. Talbot, Manet, 5 Chestnut Road,
Sutton Benger, Chippenham SN15 4RP. Tel:
01249 720342

talbot.family1@btopenworld.com **Grass
Track Recorder**

Rod Melksham, 91 Headford Avenue, Bristol,
Somerset BS5 8PE. Tel: 01179 095479

Permit Issuing Officer

Andy Scrivens andrew2.scrivens@gmail.com

Time Trial Recorder

Mr T. Colman, 23 Chestnut Road, Long Ashton,
Bristol BS41 9HR. Tel: 01275 392102

Trials Recorder

Mr P. Dury, 10 Ullswater Close, Yate,
Bristol BS37 5SS.

Wessex Centre Website Administrator

Mr Craig Talbot, 5 Chestnut Road, Sutton
Benger, Wilts, SN15 4RP. Tel: 01249
720342 ctalbot1@hotmail.co.uk

Benevolent Fund Officer

Mr M. Bracey, 3 Burden Close, Bradley Stoke,
Bristol BS32 8BL. Tel: 01179 236867

0432 Bath & West of England Motor Club Mr

Brian Allen, 1 Marsh Road, Rode,
Frome, Somerset BA11 6PE. Tel:
01373 830084
T

0433 Bristol Grass Racing Combine

Ms. Mary Derrick, 91
Headford Ave, St George,
Bristol BS5 8PE
maryderrick@tiscali.co.uk
GT

**0435 British Sporting Sidecar Association
(Wessex)**

Mr Stuart Sinclair, 35 Stanbury
Avenue, Fishponds, Bristol BS16 5AL.
Tel: 01179 571586
zsincclair10@gmail.com
T

0436 Frome & District MCC

Natalie Froud, 61 Robins Lane, Frome
BA11 3ET
natalie.froud@blueyonder.co.uk MX, T, t

0437 Kingswood MCC Ltd

Mr Richard Taylor, 60 Vayre Close,
Chipping Sodbury, South
Gloucester BS37 6NU. Tel: 01454
325485/07770
834637
richtaylor55@hotmail.com
www.kingswoodmcc.co.uk
T, t, HH

0438 Mendip Vale MC & LCC

Mr Andy Leahy, 8 Chipping Cross,
Clevedon, North Somerset, BS21 5JE.
Tel: 01275 878220
T

0439 North Somerset MSC

Paul Manning, 32 Parkwood Close,
Whitchurch, Bristol, BS14 0EA. Tel:
01275 833941
paulmanning@btinternet.com
T

0440 Swindon & District MCC

Mr Gary Wooster, Manor View, Thornhill
Road, South Marston, Swindon,
Wiltshire SN3 4RY. Tel: 01793
823069/01793 823802
gary.wooster@sky.com
www.sdmcc.org.uk
E, T, LDT

0444 Wells & District

Mr Jerry Cross. Tel: 07768 505958
crosscars@hotmail.co.uk
www.wellsdmtc.co.uk
T, t

0445 West Wilts MCC Ltd

Mrs Kay Gerken, 20 Gibbs Leaze,
Hilperton, Trowbridge, Wiltshire BA14
7QN. Tel: 01225 752784
kay@wwmc.co.uk www.wwmc.co.uk
T, HH

0447 Wilts. Border MC & LCC

Mrs Theresa Talbot, 'Mannett', 5
Chestnut Road, Sutton Benger,
Chippenham, Wiltshire SN15 4RP. Tel:
01249 720342
talbot.family1@btopenworld.com
T, t

18 ACU – WESTERN

*Area Those parts of Hereford and Worcester
and Gloucestershire situated south of a line
from Brimfield through Worcester, Evesham
and Moreton-in-Marsh to the junction of the
Oxfordshire and Warwickshire boundaries
and north of a line east/west through
Dursley.*

President

Mr A J Falconer, 2 White House Cottage,
Lower Farm, Tibberton, Glos GL19 3AQ. Tel:
01452 790577 anthony@falconer1.plus.com

Secretary

Miss J. Jones, Woodlands, Kempley
Green, Dymock Gloucester, GL18
2BW. Tel: 01531 890691/07775
524805
jennie.jones13@btinternet.com

Chairman

Mr A. Noel, 9 Finchcroft Lane, Prestbury,
Cheltenham, Gloucester GL52 5BD. Tel:
01242 244553 tony@thwen017.plus.com

Treasurer

Mr T. Welch. Tel: 01989 750298/078133 27956
tomlin.welch@btinternet.com

Permit Secretary/Police Liaison Officer Mr
R. Savery, 75 Bramley Road, Tewkesbury,
Gloucester GL20 8AQ. Tel: 01684 294932
savery75@btinternet.com

Rights of Way Officer

Mr A. J. Falconer, 2 White House Cottage,
Lower Farm, Tibberton, Gloucester GL19
3AQ. Tel: 01452 790577
anthony@falconer1.plus.com **Trials Recorder**
Mr Laurence Luff. Tel: 01453
297177 laurence@bvm-
moto.co.uk

Grass Track Recorder

Mr T Vivian, The Cottage, Blakes Lane,
Guarford, Malvern, Worcs. WR13 6NZ.
Tel: 01684 311582
vivians@themail.co.uk

Benevolent Fund Officer

Mr T Vivian, The Cottage, Blakes Lane, Guarlford, Malvern, Worcs WR13 6NZ. Tel: 01684 311582
vivians@themail.co.uk

Website Editor

Mr B Falconer
editor@acuwesterncentre.org.uk

0449 Cheltenham Home Guard MCC

Mr Anthony Falconer, 2 White House Cottages, Lower Farm, Tibberton, Gloucester GL19 3AQ. Tel: 01452 790577
anthony@falconer1.plus.com
T, LDT

0452 Dursley MC & LCC

Mr Steven Allen, 19 Rowley, Cam, Dursley, Gloucester GL11 5NT. Tel: 01453 890308
T

0453 Gloucester & Cotswold MC

Mr Dave Burry. Tel: 01531 890691
dave.burry@gmx.co.uk
T, t

0454 Golden Valley MCC

Miss Julie Short. Tel: 07961 012161
julieshort@tiscali.co.uk
T, LDT

0455 Ledbury MC & LCC

Mrs Sally Palmer, 151 Hoarwithy Road, Hereford HR2 6HE. Tel: 01432 342642/07968 649327
sallypalmer226@aol.com
GT, QGT, T

0456 Malvern & DMC & LCC

Mr T Vivian, The Cottage, Blakes Lane, Guarlford, Malvern, Worcs WR13 6NZ. Tel: 01684 311582
vivians@themail.co.uk
info@malvernmotorcycleclub.co.uk
www.malvernmotorcycleclub.co.uk
GT, T, t

0458 Stroud Valley MC

Mr Laurence Luff, laurence@bvm-moto.co.uk
http://stroudvalleymc.wordpress.com
T

0459 West Gloucester & Dean Forest MCC

secretary@wgdfmcc.org.uk
www.wgdfmcc.org.uk
T, LDT, E, SCE, HH

0460 Wye Valley AC

Mr Dan Sanders. Tel: 01981 259890
dan.sanders15@btinternet.com
T, t

0619 Zona One MCC

Mrs Kathleen Workman, The Cider House, The Green, Sheepscombe, Stroud, Gloucester GL6 7RG. Tel/Fax: 01452 813703
kathworkman@btinternet.com
T, t

Roll of Honour

Ron Carter 2009–2015
Brian Valder 2016–2017

19 ACU – WEST SOUTH WALES

Area West Glamorgan, those parts of South Glamorgan and of the Brecknock district of Powys, situated west of a line from Porthcawl through Aberdare to Builth Wells, that part of Dyfed situated south of a line from Aberystwyth to Builth Wells.

Secretary

Mr Bryan Puckett, 32 Heol Derwen, Cimla, Neath SA11 3YS. Tel: 07866 354809
bryanpuckett.acuws@gmail.com
www.welshtrials.com

President

Mr Mike Davies, Heddfan, 51 Pencrug, Llandeilo, Carm. Tel: 01558 824732
Chairman
Mr James Lamin. Tel: 01656 650618
jameslamin@btinternet.com

Treasurer/National Council Delegate Mr Graham Heywood. Tel: 01792 893457
grahamheywood@live.com

Benevolent Fund Officer

Mr Bryan Puckett, 32 Heol Derwen, Cimla, Neath, SA11 3YS. Tel: 07866 354809
bryanpuckett.acuws@gmail.com

0776 Blood Bikes Wales

Mr Peter Jones, 5 Bro Dawel, Llannon, Llanelli, Carmarthenshire, SA14 6BJ. Tel: 07855 550718
jonesrtl250@btinternet.com
T, t

0463 Dulais Valley MC

Miss Zoe James. Tel: 07875 717228
zoejames@hotmail.co.uk
www.dulaisvalleymcc.com
T

0531 Dyfed Dirt Bike Club

Meirion Scourfield, Orchard Cottage,
Noyadd Wilym, Llechryd, Cardigan SA43
2NH. Tel: 01239 682465. Mob: 07766
475801 dyfeddirtbike@hotmail.co.uk
www.ddbc.org.uk
E, HH, T

0816 Maesteg Motorcycle Club

Mark Hillier-Rees. Tel: 07872
468701
maestegmotorcycleclub@yahoo.
com
www.maestegmotorcycleclub.com
T, HH, E

0465 Neath MC

Mr Kevin Nedin. Tel: 07788
581155 kev@neathmotorclub.com
www.neathmotorclub.com
T

0744 Pembroke Vintage & Classic MCC

Mr Phil Harries, Forest Barn, Salem,
Llandeilo, Carmarthen, SA19 7NS.
Tel: 07968 168486
dpharries1@aol.com

0657 Trials Training Wales

Mr Bryan Puckett. Tel: 01639
767851 Mob: 07866 354809
www.trialstrainingwales.com

0469 Vale of Towy MCC

Mr Alan Williams. Tel: 07578 250750
lontirydail@gmail.com
T

20 ACU – YORKSHIRE

*Area That part of the Teesdale District of
Durham situated south of the River Tees, that
part of*

*North Yorkshire situated west of the railway
line from Yarm to Northallerton to the
boundary of York (excluding York) and the
west of the main York-Barlby-Howden Road
to the Humberside boundary; West Yorkshire
and South Yorkshire. Secretary*

Mrs S. Smith, 39 Lodge Gate, Denholme,
Bradford BD13 4BB. Tel: 01274 834184
sue.ykcentre@blueyonder.co.
uk

www.yorkshirecentreacu.com

uk President

Mr Martin Jackson, Highfield House,
Pickard Lane, Silsden, BD20 0JX.
sighlex@btinternet.com

Chairman

Mr M Yeadon, 169 High Street, Boston Spa,
LS23 6BH. Tel: 01937 842338

**Treasurer/Permit Officer/Police Liaison
Officer**

Mr G. E. Wilson, 160 Green Lane,
Cookridge, Leeds LS16 7JQ.

Benevolent Fund Officer

Mrs M Carter JP, 10 Byeway, Guiseley, Leeds
LS20 8JP. Tel: 01943 878666

Trials Recorder

Mr M. Timms, 131 Standon Crescent,
Winconbank S9 1PN. Tel: 01142 497027

Training Officer

Mrs P. Stephenson, 2 Dymond Road,
Liversedge, West Yorkshire WF15 7EA. Tel:
01924 403075

0795 Airedale and Pennine Motor Car Club

Helen Toft, 12 Egerton Grove,
Allerton, Bradford, BD15 8LB
helentoft78@gmail.com www.apmcc.co.uk

0557 Barnsley Trials Club Adult & Youth Ltd

Mr Alan Laybourn, 16 Coleridge
Avenue, Monk Bretton, Barnsley,
S71 2DG
a_laybourn@hotmail.com
www.barnsleytrialsclub.co.uk
t

0472 Batley Classic & Modern Trials Club

Mr Paul Hobson, 27 Grove Lane,
Gomersal, BD19 4JT. Tel: 01274
825046
paul.hobson2@btinternet.com

0473 Bradford & DMC Ltd

Miss Francesca Tattersall, 4 Aynham
Close, Grassington, BS23 5LW. Tel:
07809 294742
francescatattersall@gmail.com
secretary@bradfordtrials.com
www.bradfordtrials.co.uk
T, t

0203 BUMPY Ltd

Ms. Carolyne Kennzitt, Howden
Clough Ind Est, Leeds Road,
Birstall, West Yorkshire WF17
0JB. Tel: 01924 470432 Fax:
01924
420763 carol.kenzitt@btconnect.com
carolyn@bumpy.org.uk www.bumpy.org.
uk T, LDT

0478 Hillsborough MCC

Mr Andy Longden, 40 Crimicar Drive,
Fulwood, Sheffield, S10 4EG. Tel:
07803 898804
andylongden@hotmail.com
www.hillsboroughmcc.co.uk
T, t

0479 Horsforth & DMC Ltd

Mr Graham Wilson, 160
Green Lane, Cookridge, Leeds,
LS16 7JQ. Tel: 01132 176509
077727
24078 hdmcltd@tiscali.co.uk
www.horsforthtrials.co.uk
T, t

0480 Huddersfield Falcon MCC

Mr Michael Washington, 11 Park
Drive, Shelley, Huddersfield,
HD8 4NJ. Tel: 01484
612802/07730
572683 mikewashington@sky.com
www.falconmcc.co.uk
T, t, bt

0481 Ilkley & DMC Ltd

Mr Nick Pullan, 12 Throstle Nest
Close, Otley, LS21 2RR. Tel: 07720
260401
npullan@npullan.wanadoo.co.uk
www.ilkleymotorclub.org.uk
T, t

0482 North Riding Enduro Club

Mr Andrew Cooke, 21 St John's
Walk, Harrogate, HG1 3AJ. Tel:
01423 503090
alfcooke200@talktalk.net
www.nrec_events.co.uk
E, HH

0484 Richmond Motor Club Ltd

Mrs Sally Dent, Howraine Farm
West Burton, Leyburn, DL8
4JT.
secretary@richmondmotorclub.c
om
www.richmondmotorclub.com
BT

0485 Ripon MC Ltd

Mrs Judith Blythe, 1 Bay Horse
Cottage, Melmerby, Ripon, North
Yorkshire HG4 5HA. Tel: 01765
640319/01765 640339
T, t

0487 Spen Valley MCC

Mr Stephen Smithies, 23 The
Gardens, Heath Road, Halifax, West
Yorkshire HX1 2PL. Tel: 01422
344139
stevesmithies@outlook.com
www.spenvalleymcc.com
T, t

0491 West Leeds MC Ltd

Mr Mark Chippendale, Hillthorpe
Road, Pudsey, LS28 8NB. Tel: 07976
271967
mark.j.chippendale@gmail.com
www.westleeds.co.uk
T, t

0492 Wetherby & DMC Ltd

Mrs Margaret Myers, The
Bungalow, Low Lane, Darley,
Harrogate
HG3 2QN. Tel: 01423 781539
margaretmyers@btinternet.com
T, t

0493 Yeadon – Guiseley & DMC Ltd

Mrs W. Yeadon, 169 High Street,
Boston Spa, Wetherby, LS23 6BH. Tel:
01937 541042.
yeadonguiseley@gmail.com
www.yeadon-guiseleytrials.co.uk
t

0496 Yorkshire Classic MCC Ltd

Mr Barry Pickard, 27 Grafton Road,
Keighley, BD21 1LG. Tel: 01535 680203
barrypickard@blueyonder.co.uk
T

0495 Yorkshire Enduro Club

Mr N Marriott, Acorn Cottage, 2 Red
Beck Cottages, Horsforth, Leeds, LS18
3EQ. Tel: 0113 250 9639
slyness@aol.com
www.enduroneec.org.uk
E

21 SCOTTISH AUTO CYCLE UNION

Office Manager

Mr Charles Mackenzie

Admin Officer

Miss Stella Clusker, 28 West Main Street,
Uphall, West Lothian EH52 5DW. Tel: 01506
858354 office@sacu.co.uk www.sacu.co.uk

Chairman

Maj A Mack MBE, 6 The Pleasance,
Aberlady, East Lothian, EH32 0RG. Tel:
07584 750941

Treasurer

Mr A McNaughton, 12 Kirkintilloch Road,
Bishopbriggs, G64 2AX. Tel: 0141 772
5924

Secretary

Mr Donald Young. Tel: 0781 7336622

Acting President

Mr Dave Paton. Tel: 0131 448 0218

Child Protection Officer

TBC

Road Race Recorder

Diana Dyce, 10 Garleton Drive,
Haddington EH41 3BL. Tel: 01620
825488 diana.dyce@gmail.com

Trials Recorder

Bill Ross, b.ross@hydromax.com

Enduro Recorder

Mr Charles Mackenzie. Tel: 0131 443 4275 charlie@scottishenduros.co.uk
ACU/SACU Benevolent Fund Officer
 Charles Mackenzie c/o 28 West Main Street, Uphall, West Lothian, EH52 5DW. Tel: 01506 858354 office@sacu.co.uk

Bob MacGregor Motorcycle Club

Mrs Karen Lafferty, Lagan Main Street, Killin, KK21 8UT
 bobmacgregormemorialtrial@hotmail.com

Bon Accord MCC

Mrs Diane Stuart, 3 Woodview Place, Stonehaven AB39 2TD. Tel: 01569 763025

Dalmellington MCC

Heather Anderson, 4 Gateside Cottages, Sanquhar, Dumfriesshire DG4 6JP. Tel: 01659 50137 hqueenie4@sky.com

DirtBike Evolution

Natalie Currie. Tel: 07596 367669 dirtbikeevolution@btinternet.com

Drumclog MotoParc

Janice Johnston. Tel: 078333 26660 1960janj@gmail.com

Dunfermline & District MCC

Kirsten Pennycock, 1 Lochtyside Cottages, Thornton, Fife, KY1 4DE. Tel: 07882 671887

East Lothian Motorcycle Club

Mrs Margaret Mack, 6 The Pleasance, Aberlady, East Lothian, EH32 0RG. Tel: 079440 27930 stuartnumber@live.com

East Lothian Road & Trail Club

Ms. Caroline Thomson. Tel: 07900 361876 carolinethomsonlxii@gmail.com

Ecosse-XC

James Dods. Tel: 07876 616977 jdods@hotmail.co.uk

Edinburgh & District MC Ltd

Adrienne Whitham secretaryedmc@gmail.com

Edinburgh St. George MC

Ms. C. Dalling, Newland Cottage, Newlandrigg, Gorebridge, Midlothian EH23 4NS. Tel: 01875 820349 creenadalling@gmail.com

Elgin Endurance Club

Contact SACU Office office@sacu.co.uk www.elginenduranceclub.com

Galloway MCC

Mr Wullie Brown. Tel: 07740 645103 wulliebroon@tiscali.co.uk

Hawick & Borders MCC

Mr James Steel, Douglas Cottage, Ancrum, Jedburgh, TD8 6XH. Tel: 01835 830422 jimmiesteel@hotmail.com

Highland Enduro Club

Mr Craig Mackay, craigwmackay@hotmail.com

Inverness & District MCC

Mr John Moffat, 43 Oakdene Court, Culloden, Inverness, IV2 7XL. Tel: 07790 457479 idmcc@outlook.com www.idmcc.co.uk

Kingdom Off Road Motorcycle Club

Mr David Paton. Tel: 07921 857283 davidpaton70@hotmail.co.uk

Kinlochleven MCC

Lorna Dougan. Tel: 07969 338 219, lornadougan@gmail.com

Kirkcaldy & District MC Ltd

Mr Jake Drummond, 7 Main Street, Coaltown of Wemyss, Fife, KY1 4NT. Tel: 07473 174449 unionmills@virginmedia.com

Knockhill Motorsports Club Ltd

Ms Gemma Hobbs, Knockhill Racing Circuit, Dunfermline, Fife KY12 9TF. Tel: 01383 723337 gemma@knockhill.co.uk www.club.knockhill.com

Lanarkshire MCC Ltd

Mr Malcolm Marshall, marshallmm10@gmail.com www.lmcc.co.uk

Lochaber & District MC

Mr C Allison, The Croft, Stronaba, Spean Bridge, Fort William, PH34 4DX. Tel: 0746 9939 284 ldmcc@outlook.com

Loch Lomond MCC

Mr Ian Middleton, 34 Hazel Avenue, Bearsden, Glasgow G61 2HF. Tel: 0141 585 0039 i.middleton@ntlworld.com

Melville MC (Scot) Ltd

Diana Dyce, diana.dyce@gmail.com

Mid Argyll Motocross Club

Mr Stewart Campbell, Barr Nan Croabh, Kilmichael Glassary, Lochgilphead, Argyll PA31 8QD. Tel: 01546 606852 Campbell.5@btinternet.com

Moto 316

Stuart Flockhart. Tel: 07841 473009
stuart@flockhartmx.com

Perth & District MC

Mrs Jean Paterson, 1 Strathearn
Terrace, Crieff, Perthshire PH7 3DT.
Tel: 01764 654774
jeanpaterson.pdmc@gmail.com
www.perthanddistrictmotorclub.co.uk

Quad Racing Scotland

Mrs Ann Wood, Haildean Mill, Melrose
TD6 9DW ann@scottsvieview.co.uk

Rhins MCC

Mrs Ann Slavin, Inch Cottage, Castle
Kennedy, Stranraer DG9 8RU. Tel:
01776 705684 annslavin7@aol.com

Scottish Borders Enduro Club

Andy Thomson, Mob: 07774 470002,
pamela@quarrybankgarage.co.uk

Scottish Classic Racing MCC

Mrs Agnes Cadger, Cronk-Ny-
Mona, Caddell Farm,
Saltcoats KA21 6NE. Tel:
01294 833320
agnescadger@tiscali.co.uk

Scottish Sidecar Racing Club

Mr Murray McKay, 24 Cameron
Crescent, Kippen, Stirling FK8 3EH. Tel:
07713 689038
murray.mckay@hotmail.co.uk

Scottish Vintage Racing Club

Mr Andrew Johnstone, 32 Regent
Place, Edinburgh EH7 5BG. Tel: 0131
6612290
andrewjohnstone.13@gmail.com

Stevenson & District MCC

Mr G Crawford, 32 Moorburn Road,
Largs, KA30 9HX. Tel: 01475 689586
graeme.crawford@sportscotland.org.uk

VMCC Central Scottish Section (CSS)

Mr Arthur Merchant, 56 Carlogie
Road, Carnoustie, Angus DD7 6EY. Tel:
01241 852369

VMCC Stirling Castle Section (SCS)

Dr Stuart Wilson, 10 Braeval,
Aberfoyle, FK8 3UY. Tel: 07731
501413
stuartwilson3@gmail.com
www.stirlingcastlevmcc.co.uk

**ASSOCIATE MEMBER CLUBS OF
SCOTTISH AUTO CYCLE UNION**

I-Moto X

Miss Gemma McColl,
gemma@i-touches-
imotox.com

Rural & Urban Training Scheme

Mr Iain Bell, Former Central
Workshops, Scottish Mining Museum,
Newtongrange, Midlothian EH22 4QN.
Tel: 0131 6635736 or 07577 293858
or Iain Bell iainb@ruts.co.uk

Scottish Motorcycle Marshals Association

Mr Bob Davies. Tel: 07852 461696
smileybob@sky.com
www.imarshal.co.uk

Timekeepers & timing equipment

AUTHORITY

The ACU appoints all grades of timekeeper. Persons operating timing equipment to an accuracy of greater than 1 second must be licensed.

DUTIES

Each timekeeper is responsible for the authenticity of the times taken and the results issued, substantiated by having the correct licence for the grade of event and by using the appropriate correct identifiable equipment for the type and grade of the event.

Timekeepers are categorised as follows:

FIM TIMEKEEPERS. Who may take charge of the timing of any event as licensed by the FIM.

They are particularly appointed to take charge of the timing at events counting towards a World Championship or FIM title and at World Record attempts.

GROUP 1 TIMEKEEPERS. Chief timekeeper for National or International meetings.

DUTIES AND RESPONSIBILITIES OF A GROUP 1 TIMEKEEPER

In order to achieve the grade of Group 1 timekeeper, the applicant must have served at and taken charge of at least ten events over two consecutive seasons under the supervision of senior timekeepers. At least two of those events will be subject to the appraisal of an approved mentor, at one venue known to the applicant and one nominated venue.

Individually, all Grade 1 timekeepers may be subject to appraisal and interview by at least one senior timekeeper nominated by the ACU.

Appointments to International grade remain the sole responsibility of the ACU.

In exceptional circumstances the timescales quoted above may be altered after reference to the respective organisers, Chief timekeepers and/or the ACU.

The ACU reserves the right to amend and change the grades of all timekeepers. The applicant will be appraised in accordance with the following criteria:

PLANNING

The timekeeper will demonstrate an ability to plan the equipment requirement for the event. He/she will ensure that the needs of the organisers are met as follows:

- The timing equipment selected for the event is appropriate and matches the requirements of the organisers.
- The timing equipment selected has the correct and valid certificate of accuracy.
- The beams, cabling and associated equipment are compatible with the timers.
- The results equipment is appropriate for the service required, and if electronically linked to the timing equipment, the two are compatible.
- The backup equipment is appropriate for the event.
- The timer and associated equipment is checked for readiness for use.

PLANNING THE PERSONNEL

- The licence grades and competencies of the personnel are appropriate for the event.
- The number of personnel is adequate for the event.
- All personnel are informed of their duties in adequate time.
- Transport arrangements, accommodation and arrival times are clear and appropriate.

The timekeeper will be able to identify risks in the planning and deal with any contingencies.

ORGANISATION AND MANAGEMENT

- The range of duties needed for the event is identified
- All timing service personnel sign the ACU disclaimer.
- Duties are allocated according to the competencies of individuals.
- Duties and requirements are explained and understood by all team members.
- Appropriate lines of communication between the timing team and the organisers are identified, agreed and established.
- Prior to and throughout the event risks are identified and dealt with efficiently and effectively.

- All team members are treated in a courteous manner.
- Identify risks in the above and deal with any contingencies.

COMMUNICATION WITH OFFICIALS, COMPETITORS, COORDINATORS AND OTHER RELEVANT PERSONS

- The roles, responsibilities and identities of the officials and other event personnel are understood by the timing team.
- All persons are dealt with in a courteous and polite manner.
- All requests for information or services required from the team are assigned to the appropriate personnel to answer or provide.
- Such requests are dealt with in a clear and concise manner without undue delay.
- Identify risks in the above and deal with any contingencies.

IDENTIFICATION AND DEVELOPMENT OF TIMING PERSONNEL NEEDS

- The competencies and abilities of the timekeepers are identified.
- Appropriate training programmes are identified to match individual requirements.

GROUP 2 TIMEKEEPERS. Take charge of events up to Club level.

GROUP 3 TIMEKEEPERS. Assistant to the Chief timekeeper at events.

GROUP 4 TIMEKEEPERS. Trainee, they are encouraged to assist more senior timekeepers.

RACE RECORDERS. Assist the timekeeper by recording the number of laps and finishing order including retirements of competitors at a race event.

The differing type of events licensed by the ACU means that the organising club must identify an event's timing needs, with the Chief Timekeeper.

TIMEKEEPER'S EXPENSES

Expenses are subject to agreement between the organising Club and the Chief Timekeeper prior to the event.

TIMEKEEPING SUB PANEL

Mr M. Corfe – Chairman
 Mr R. Humphrey Mr G. Lond Mr
 A. Smith Mr S. Taylor
 Mr J. A. Ward

TIMEKEEPING EQUIPMENT TESTERS

Certification of equipment may be carried out by the following. A fee will be charged, for details please contact those listed direct:

T. Saunders, 48 Broadlands Drive, Malvern, Worcester WR14 1PW. Tel: 01684 894884/01684 561966.

FIM TIMEKEEPERS

For a list of current FIM Timekeepers please contact the ACU head office on 01788 566405.

Technical officials

TECHNICAL OFFICIAL GRADING

1 INTERNATIONAL TECHNICAL STEWARD

2 SENIOR TECHNICAL OFFICIAL

3 TECHNICAL OFFICIAL

Also: **Technical Assistant(s)** acts in a supportive capacity to the Technical Team. May be appointed by the Senior Technical Official

for the duration of an event, at any level of competition. Working under strict supervision.

TECHNICAL OFFICIAL

Authorised by the Permit Issuing Authority to form part of a Technical Control Team, applicants should have knowledge of motorcycle engineering practice, be familiar with the Technical Rules in the current ACU Handbook and the National Sporting Code and have attended a suitable training seminar. They may officiate at any discipline. They may take charge of a Closed to Club or Restricted meeting at disciplines for which they are trained, other than Road Racing related events. They must attend a training course every 3 years, which may be held on a regional basis. Minimum age 18 years.

UpGRADING TO SENIOR TECHNICAL OFFICIAL

The applicant must be able to demonstrate a need to upgrade (i.e. will be taking charge of a meeting within the following 12 months). The applicant should have assisted at a minimum of ten meetings in two years and attended a National Technical Official's Seminar as a Technical Official at ACU House, Rugby.

Questions on relevant ACU and FIM Rules will be asked. Reference to handbooks will be permitted. An application for upgrading must be supported by the applicant's service record and recommendations as to suitability from two Senior Technical Officials. Due account will be taken of any discipline specialisation.

The Technical Panel will consider fast track upgrade to Senior Technical Official status for candidates who are Chartered Engineers or have equal experience.

SENIOR TECHNICAL OFFICIAL

Authorised by the Permit Issuing Authority to

take charge of the Technical Control Team at events of National status and below, may also assist at higher status and take charge at lower status events. They are able to officiate at all disciplines or at disciplines as licensed. Persons holding this licence must attend a training course/seminar at ACU House, Rugby every 3 years.

This is the minimum qualification required to take charge at a road race related event.

UpGRADING TO INTERNATIONAL TECHNICAL STEWARD (FIM)

The applicant must have attended Technical Steward Seminars, passed the FIM Examination and have attained a three year qualification.

Must be an authorised ACU Measurer and Sound Inspector, and have demonstrated an ability to organise and control the Technical Control Team as an effective Manager, be able to report fully to an International Jury or Clerk of the Course and have an above average knowledge of General and Technical Regulations and of motorcycle engineering practice.

Must have been recommended by the Clerk of the Course at ten National meetings while acting as Senior Technical Official and by the International Technical Steward at five International meetings while acting as Deputy to the Chief Technical Official.

INTERNATIONAL TECHNICAL STEWARD (FIM)

May take charge of the Technical Control Team at all International events and may also take charge or be a Team Member at any status event. They are by definition capable of officiating at all disciplines and at all levels.

AppLICATIONS FOR RENEWAL OR UpGRADING

Shall be made to the Secretary of the ACU Technical Panel by 1st October each year. Applications must be accompanied by a recent passport photograph and the applicants service record. Downgrading or withholding of a Technical Official's licence may occur due to adverse reports, lack of Technical Duties in any

one season or non attendances at a National Technical Officials Seminar within the last 3 years. All regrading will be at the absolute discretion of the Technical Panel.

SOUND LEVEL TESTING

Sound Inspectors are licensed by the ACU.

SOUND INSPECTORS

Will be considered “judges of fact” with regard to sound level test results and will report to the Clerk of the Course accordingly. Clerks of the Course should take all necessary action on being notified of excessive noise by a Sound Inspector.

Sound level control

For 2020 two sound test methods will be employed.

- 1 The existing static RPM test
- 2 The FIM 2 Metre Max test.

Both tests are internationally approved.

STATIC TEST METHOD

The sound level meter microphone to be placed 500mm from the exhaust pipe end, at an angle of 45 degrees measured from the exhaust centre line as near as possible to the height of the exhaust end, at least 20cm above the ground. During a sound level test, machines not equipped with a gear box neutral must be placed on a stand.

The driver shall keep his engine running out of gear and shall increase the engine speed until it reaches the specified RPM. Measurements must be taken when the specified RPM level is reached. The RPM depends upon the mean piston speed corresponding to the stroke of the engine (see the stroke/RPM table).

2 METRE MAX METHOD

The set up of the sound meter and the motorcycle.

The sound levels will be measured with the sound meter/microphone fixed on a tripod, in the horizontal position, at the rear of the motorcycle.

The sound meter will be positioned at a distance of 2 metres behind the motorcycle, with an angle of 45 degrees away from the centerline, on the exhaust side and at a height of 1.35m above the ground. The 2m distance is measured from the point where the centre of the rear tyre touches the ground. The throttle is opened to maximum for no more than 1 second or before the rev limiter is reached.

It is preferred to make the tests on a soft ground, not reverberating, i.e grass or fine gravel.

The test should only be carried out after engines have been "warmed up" to operating temperature.

The ambient sound level must remain below 95-100 dBA.

There is no tolerance for temperature.

Whichever test method is in use temporary silencers, bypass pipes or the inclusion of temporary parts to achieve the silencing requirements are prohibited.

FIM & ACU MAXIMUM SOUND LEVELS

See current Standing Regulations

ROAD RACING AND TT SEE ROAD RACE STANDING REGULATIONS

No change to Sound tests, the existing Static RPM test will be used.

MOTOCROSS

Two tests will be in operation.

- 1 The Static test method - For Twinshock and Evo classes only.
- 2 The FIM 2 Metre Max Test - For machines post 2011.

SOLO

- For machines 2013 and onwards - maximum sound limit 112dB/A (+2 dB/A before each race, +3 dB/A after the race) tested using the 2 Metre Max method. Type 1 and Type 2 meters.
- For 2010-2012 machines - maximum sound limit 115 dB/A (+2 dB/A before each race, +3 dB/A after the race) tested using the 2 Metre Max method. A further review to be made at the end of 2020.

SIDECARS

Maximum sound limit for 2 stroke engines at 112 dB/A (+2 dB/A before the race, +3 dB/A after the race). For 4 stroke engines at 115 dB/A (+2 dB/A before the race, +3 dB/A after the race) tested using the 2 Meter Max method.

A further review to be made at the end of 2020.

qUADS

Maximum sound limit 112 dB/A (+2 dB/A type 1 & type 2 meters before each race) (+3 dB/A type 1 & type 2 meters after each race) tested using the 2 Metre Max method.

A further review to be made at the end of 2020.

PROCEDURE

All machines shall be sound tested using the 2 Metre Max method, the exceptions being Twinshock and Evo classes. The static test will prevail with a test limit of 96 dBA for 2 strokes and 94 dBA for 4 strokes, using the fixed RPM according to the list below, with the exception of the 500cc class.

Up to 85cc	8,000rp
m	
Over 85cc up to 125cc	7,000rp
m	
Over 125cc up to 145cc	6,500rp
m	
Over 145cc up to 250cc	5,000rp
m	
Over 250cc up to 500cc	4,500rp
m	
Over 500cc	4,000rp

There is no 2 stroke/4 stroke rev differential below 500cc. Due to the influence of temperatures on sound tests, all figures are correct at 20°C. For tests taken at temperatures below 10°C there will be a + 1 dBA tolerance. For tests below 0°C, a + 2 dBA tolerance. There will be a + 2 dBA tolerance allowed for post race sound tests.

MACHINES POST 2011

The FIM 2 Metre Max Test Method will be enforced as previously detailed. The maximum sound limit accepted: 115 dBA-+ 1 dBA post race. A sound level of 81 dBA at 100 metres during racing should be attained.

TRIALS & ENDURO

TRIALS

Only the 2 Metre Max test method will be used as previously detailed. The maximum sound limit accepted will be 100dBA before the Start (+2 dBA during or after the event).

ENDURO

Only the 2 Metre Max test method will be used as previously detailed. The maximum sound limit accepted will be 112 dBA before the Start (+2 dBA during or after the event).

GRASS TRACK, LONG TRACK & BEACH RACE

The FIM 2 Metre Max test will be utilised as previously detailed and directed below.

CLASSES

500cc Solo and Sidecar classes

Machines to be fitted with the 2010 FIM homologated silencer. Ref TRS 2010.

Any machine using an alternative silencer will be subject to Sound Control using the FIM 2 Metre Max test method.

250cc and 350cc Solo classes

Can use the 2005 or later FIM homologated silencer.

Any machine using an alternative silencer will be subject to Sound Control using the 2 Meter Max method.

Pre 75 and Upright Solos classes

As for 250cc and 350cc classes as detailed above.

1000cc Sidecar class

Silencer construction is free.

Machines will be subject to sound control using a "Ride By" method with a maximum sound level of 85 dBA.

If a rider disputes the results of the "Ride By" test the machine will be tested using the "2 Metre Max" method, see the Grass Track Rules 4.14.

2 METRE MAX TEST

The maximum sound limit accepted will be 115 dBA (+2 dB/A before the race, +3 dB/A after the race).

A SOUND LIMIT of 81 dBA at 100 metres.

SpEEDWAY

Maximum sound level using the 2M Max Test, at 11,000rpm. 112dBA other than machines using FIM 2015 Homologated Silencers.

GENERAL

STATIC RPM TEST

The ambient sound level within a 5 metre radius from the machine being tested should be at least 10 dBA below the maximum level permitted for the discipline.

FIM 2 METRE MAX TEST

The ambient sound level within a radius of 10 metres of the machine being tested should not exceed 100 dBA.

SOUND METERS

Sound level meter minimum standard for enforcement are IEC 651 IEC 60651 or IEC 61672 Type 2.

SOUND CONTROL – RpM FIGURES – APPLICATION

13metres/sec – TWO STROKES i.e.

Road Racing where applicable.

11 metres/sec – FOUR STROKES i.e. Road Racing where applicable and ALL Trials and Enduro machines (two and four stroke).

Stroke in mm	Mean Piston Speed 13m/sec	Mean Piston Speed 11m/sec	Stroke in mm	Mean Piston Speed 13m/sec	Mean Piston Speed 11m/sec
30	13000	11000	66	5909	5000
31	12580	10645	67	5820	4925
32	12187	10313	68	5735	4853
33	11818	10000	69	5652	4783
34	11470	9706	70	5571	4714
35	11142	9429	71	5492	4648
36	10833	9167	72	5416	4583
37	10540	8919	73	5342	4521
38	10263	8684	74	5270	4459
39	10000	8462	75	5200	4400
40	9750	8250	76	5132	4342
41	9512	8049	77	5065	4286
42	9285	7857	78	5000	4231
43	9069	7674	79	4937	4177
44	8863	7500	80	4875	4125
45	8666	7333	81	4815	4074
46	8478	7174	82	4756	4024
47	8297	7021	83	4699	3976
48	8125	6875	84	4643	3929
49	7959	6735	85	4588	3882
50	7800	6600	86	4535	3837
51	7647	6471	87	4483	3793
52	7500	6346	88	4432	3750
53	7358	6226	89	4382	3708
54	7222	6111	90	4333	3667
55	7090	6000	91	4286	3626
56	6964	5893	92	4239	3587
57	6842	5789	93	4194	3548
58	6724	5690	94	4149	3510
59	6610	5593	95	4105	3474
60	6500	5500	96	4063	3438
61	6393	5410	97	4021	3402
62	6290	5323	98	3980	3367
63	6190	5238	99	3939	3333
64	6093	5156	100	3900	3300
65	6000	5077			

Fuel regulations – National ACU

puRPOSE OF REGULATION

The purpose of these Articles is to ensure that the fuel used in competition is unleaded 'pump petrol' as this term is generally understood.

These detailed requirements are intended to achieve this purpose whilst allowing the use of consistent petrols for racing purposes. Any petrol which appears to have been formulated in order to subvert the purpose of this regulation will be deemed to be outside it. Lead replacement petrol (LRP) is not considered to be unleaded petrol.

FUEL, FUEL/OIL MIXTURES

UNLEADED PETROL as defined by European Committee for Standardisation (CEN), EN 228 (2004) or BS EN 228 (British Standards BS7070) must be used for Road Racing (exceptions in Road Racing rules), Motocross, Trials, Enduro and some classes in Drag Racing, Sprint, and Track Racing. (See individual discipline rules). Unleaded petrol must comply with the ACU specification with the following characteristics:

For: Road Racing, Trials, Enduro

Property	Units	Min.	Max.	Test Method
RON		95.0	102.0	ISO 5164
MON		85.0	90.0	ISO 5163
Oxygen	% m/m		2.7	ASTM D 5622 ASTM D 4815
Nitrogen	% m/m		0.2	ASTM D 4629
Benzene	% v/v		1.0	EN238

For: Motocross and Track Racing

Property	Units	Min.	Max.	Test Method
RON		95.0	102.0	ISO 5164 or ASTM D2699
MON		85.0	90.0	ISO 5163 or ASTM D2700
Oxygen (includes 10% Ethanol allowance)	% m/m		3.7	ISO 22854 or EN13132 Or elemental analysis
Nitrogen	% m/m		0.2	ASTM D 4629 or ASTM 5762
Benzene	% v/v		1.0	ISO22854 or ASTM D6839 or ASTM D5580

And other characteristics according to the current ACU specification. Available from the Technical Secretary, ACU, Rugby. Any infringement of the fuel specifications will automatically result in the exclusion of the competitor from the entire meeting. The result of the competitors' fuel sample analysis (A or B Sample) more favorable to the competitor will be taken into account.

AIR

Only ambient air may be mixed with the fuel as an oxidant. Unless otherwise specified in Standing Regulations, fuel additives are not permitted.

BIO-FUELS

E85 Bio-ethanol pump fuel may be used where specifically allowed by the sporting discipline Committee.

E85 Bio-ethanol fuel is defined by CWA 15293:2005 (automotive fuels, ethanol E85, requirements and test methods) standards and is a road legal, publicly available fuel.

SAMpLING – ROAD RACE AND SUPERMOTO

Fuel samples may be taken, to ensure compliance with the ACU Fuel Regulations at any time or place during the course of an event.

- The Chief Technical Officer with the agreement of the Clerk of the Course may take or supervise the taking of up to 1.5 litres of fuel from any competition machine.
- Containers used must be clean and of a type certified suitable for holding petrol samples.
- Each sample taken must be divided into two and placed in separate 1 litre containers.
(1 litre approximately in one and 0.5 litre approximately in the other). The containers must be sealed immediately and identified by reference to the machine from which the sample was taken. This information must be entered on a certificate which must certify the date, place and time of taking the sample and the seal numbers of both the 1 litre (the 'A' sample) and 0.5 litre (the 'B' sample) containers.
- Sample 'A' must remain in the control of the Chief Technical Officer for delivery to an ACU approved 'Fuel Test Laboratory'. Sample 'B' must be given to the rider or his authorised representative who must sign the fuel sample certificate, acknowledging receipt.
- Samples taken for routine control must be tested for compliance with at least three of the characteristics listed – A fuel test result will be said to be 'in compliance with' or 'not' in compliance with the characteristics tested for.
- When fuel is tested for any other reason all characteristics listed must be proved.

SAMpLING – OFF ROAD DISCIPLINES

- 1) The ACU appointed Official has the sole responsibility for the management and supervision during the taking of fuel samples.
- 2) The preferred fuel test method in a first step is Gas chromatography or GC Fingerprint method. Gas chromatography (GC) is an analytical technique for separating compounds based primarily on their volatility and polarity. Gas chromatography provides both qualitative and quantitative

information for individual compounds present in a sample. Gas chromatography is widely used for the analysis of fuels. The GC Fingerprint is a comparison between the given reference and the fuel drawn from the competitor's motorcycle. With the fingerprint method any changes in the composition and concentration of the fuel against the reference is detected. The separation is done with a non polar column suitable for fuel analysis. The detection of the components is done with a flame ionisation detector.

- 3) If other test methods are required, fuel samples are transported to the appointed laboratory by an official courier, using the appropriate containers.
- 4) Riders selected for fuel controls are directed with their motorcycles to the inspection area.
- 5) Only new sample bottles are used for the fuel samples.
- 6) The fuel to be tested is transferred directly from the selected fuel tank into three vials (3 small sample containers), marked A, B and C and identified by reference to the motorcycle from which the sample was taken. The bottles are closed, sealed and labelled by the ACU appointed Official.
- 7) The Fuel Sample Declaration form (see 14) is filled out immediately, containing all information as shown on the sample sheet, including the rider's name and race number, date and place of fuel sampling. A responsible team member signs this declaration, after verifying that all the information is correct.
- 8) Samples A and B are given to the appointed laboratory staff, present at the event for analysis or be sent to the respective laboratory by the organiser if no trackside laboratory is available. Sample B will be kept by the laboratory staff as a reserve sample, to be used for a second analysis if required. All samples are accompanied by a copy of the Fuel Sample Declaration form. Costs for the analyses of sample A and B are paid by ACU.
- 9) Sample C is handed over to the ACU, accompanied by a copy of the Fuel Sample Declaration form, for safeguarding in case

- of protests and/or a request for a counter- expertise by the ACU appointed laboratory. Costs for the analyses of sample C are paid by the team concerned.
- 10) As soon as possible after completing the testing, the Fuel Analyst/ACU appointed laboratory will report the results of the fuel sample analyses directly to the ACU appointed Official, with a copy to the rider and the Discipline Committee.
 - 11) In the case of non-conformity of the fuel, the ACU appointed Official must notify the results to the Discipline Committee and the rider/team representative concerned. Failure of the sample to conform to the ACU fuel specifications results in the disqualification of the competitor from the entire meeting. The result of the competitor's fuel sample analysis ("A" or "B" sample) more favourable to the competitor is taken into account. Note: The non-conformity of one property (except the Appearance) is sufficient for declaring the non-conformity of the fuel or the mixture.
 - 12) Within 48 hours of the receipt of the notification of the results from the analysis of sample A and/or B, the team must notify the Discipline Committee and the ACU appointed Official if a counter-expertise of sample C is requested.
 - 13) The Discipline Committee takes a decision, immediately following the notification of the results of the final expertise. Any appeal against the decision of the Discipline Committee is heard by the ACU Judicial Panel.
- Have his/her licence suspended for a minimum period of six months of the 'season' March to October inclusive.
 - Be disqualified from the results.
 - Lose any championship points that may have been earned at the meeting.

FUEL TEST COSTS AND pENALTIES

When following routine testing fuel found to be not in compliance with the ACU/FIM Fuel Regulations the competitor involved will be liable for the relevant testing costs. When fuel is tested as a result of a protest the protest fee must be accompanied by a 'Nominal Testing Charge' of £600 and the losing party will be liable for all the testing costs. In the event of the protest being upheld the 'Nominal Testing Charge' will be returned. Any competitor who fails to provide a fuel sample when requested to, or whose fuel is found to be not in compliance with these regulations will:

ACU approved protective helmets and visors

The only indication that a helmet is suitable for immediate use in motorcycle sport is the ACU gold sticker firmly affixed, as displayed below.



GOLD APPROVAL The minimum standard for Road Racing, Sprints, Drag Racing, Hill Climb and any speed events held wholly or part on bound metallised surfaces.

YOUTH SPORT: The choice of helmet type 'full face' (integral) or 'open face' with or without detachable chin guard, is at the discretion of the licence holder AND the parent or legal guardian of the licence holder. Great care must always be exercised in choosing a full face helmet for a young person, too large a size must not be selected in order to ease head entry or to allow for head growth. Packing must not be used to improve the fit of a helmet too large in original size.

TRIALS: Trials riders must wear a suitable road legal helmet.

It is considered that any person selling a helmet for competition use as "ACU Approved" without an approval sticker firmly affixed IS making a false trade description.

EXEMPTION

A rider or passenger from another Country holding a licence endorsed by his/her FMN and carrying proof of insurance issued by his/ her FMN, may wear a helmet without an ACU Approval sticker but complying with FIM Art. 01.67 (displaying a recognised International Helmet Standard).

HELMET MODIFICATIONS

Please note that any modification to a helmet structure immediately invalidates ACU approval. Any helmet modified by the cutting, drilling or puncturing of the shell in any way subsequent to its leaving the manufacturer, will be rejected at technical inspection and the ACU approval sticker will be removed.

HELMET PAINTING

Painting of helmets of laminated composite construction (glass fibre, Kevlar etc.) is permitted. However, parts bonded on, such as the visor aperture surround or the energy absorbing lining must **not** be removed even by professional customisers. The removal of the visor pivots, vents and controls should only be done if attached by screws etc. "sprung in parts" should be carefully masked around before painting, as bonded items. Moulded plastic helmets of polycarbonate, ABS etc must **not** be painted.

Vinyl wraps as customisation of helmets is permitted in a similar manner to painting. Competitors should make sure the adhesive used is compatible with the helmet material.

HELMET SECURITY

Many helmets have a type of buckle (Double 'D' Ring or Sliding Bar) requiring strap tension to maintain security. Riders should be aware that strap slip can occur through this type of buckle even on new helmets, be sure to maintain some strap tension at all times.

Even during the relatively short period of a race, strap slip can be sufficient to increase the risk of helmet loss in the event of an accident. It can be minimised by securing the flapping strap end by some means such as a rubber band.

HELMET PROJECTIONS

(Fins, stabilisers, cameras etc.) Attachments to the shell surface exceeding 20mm height are not permitted in Road Racing.

VISORS/GOGGLES

For Road Racing, visors to the highest British Standards Institution grade of impact and abrasion resistance are recommended.

TECHNICAL INSPECTION OF HELMETS

Helmets are examined at technical inspection in order to assess wear and tear, general deterioration and to ensure that an ACU Approval sticker is displayed.

The Senior Technical Officer of an event has the power to impound for the day, any helmet he considers is not in a fit condition to be used. He is authorised to remove the ACU approval sticker, which remains the property of the Auto Cycle Union. The helmet may be submitted for a second opinion to the Technical Secretary, but in any case may not be used without being re-checked.

Competitors with long hair – Long hair must be contained within the helmet or clothing.

MOULDED pLASTIC HELMETS

Many helmets with moulded plastic shells of thermoplastic material meet with ACU requirements and bear the Union's mark of approval. However, it must be stressed that helmets manufactured from this material may be seriously damaged by substances such as petrol, paint, adhesives, cleaning agents and decorative stickers.

TEN FITTING TESTS FOR HELMETS

1. Obtain correct size by measuring the circumference of the head immediately above the eyes in cm.
2. Check there is no side to side movement.
3. Tighten strap securely.
4. With head forward attempt to pull up back of helmet to ensure helmet cannot be removed in this way.
5. Check ability to see clearly over shoulder.
6. Make sure nothing impedes your breathing in the helmet and never cover nose or mouth.
7. Never wind scarf around neck so that air is stopped from entering the helmet. Never wear a scarf under the retention strap.
8. Ensure that visor can be opened with one gloved hand.

9. Satisfy yourself that the back of your helmet is designed to protect your neck.
10. Always buy the best you can afford.

Make sure that the helmet has an ACU Approval Sticker affixed.

Never buy from mail-order unless you are satisfied with the above tests.

Do not hesitate to return the helmet unused if it does not fit you.

HELMET STAMPING

Manufacturers and importers of helmets may seek approval for their products and a licence to affix relevant Gold or Silver approval stickers to their helmets by providing helmets for the Independent testing in addition to other type approval documentation as part of the approval process. Please contact the Technical Department for further information.

Exceptionally, helmets may be individually approved, (often after painting etc.) They can be mailed for approval and the affixing of a relevant sticker. They should be sent to:

ACU, ACU House, Wood Street, Rugby,
Warwickshire CV21 2YX. Tel: 01788
566400 A fee of £15.00 should also be
enclosed

which covers return post and packing charges.

Competition Licence/Trial Registration

A Competition Licence (or Registration in the case of Trials) is required by every rider and passenger participating in any competition held under the National Sporting Code of the ACU.

It is the responsibility of the competitor, or in the case of minors the parent or legal guardian, to ensure that their licence is valid and issued for the correct class. The issuing of a licence does not guarantee an entry into, or acceptance into, any competition. All licences are valid from 1 January to 31 December of the year of issue. Licence fees are non-refundable.

Duplicate ACU licences can be obtained on request at a cost of £5.00. Duplicate FIM/FIME licences can be obtained through the ACU at the appropriate fee.

One event licences

A One Event licence grants all the benefits of an annual licence for the duration of one named event only.

The Supplementary Regulations for the event will state whether this type of licence can be used.

One Event Licences are valid only for adult and youth riders in the undermentioned events:

- i) Motocross, Supermoto and Enduro events up to and including National Status.
- ii) Grass Track, Sprint, Drag and Hillclimb events below National Status.

Note: One Event Licences are not issued for Road Race events.

For competitors who have not previously held an ACU competition licence or for those competitors who have not held an ACU competition licence for a period of three years, a one event licence may be submitted with an application for an ACU competition licence to receive a £10.00 credit on the purchase of an

ACU competition licence within six months of the purchase of the one event licence in any calendar year period. The credit cannot be carried over from one year to the next.

It should be noted that only one One Event Licence can be used to offset the cost of an annual ACU competition licence. It is the overall responsibility of the Clerk of the Course to ensure that all One Event Licence counterfoils are returned to ACU Head Office within 14 days of the event being completed. Although it is recognised this task may be delegated, the responsibility for ensuring this happens remains with the Clerk of the Course.

One event trials licences

To encourage non-ACU Trials Registered Riders to attend ACU Trials events, One Event Trials Registrations are now available from ACU

Head Office. Riders taking out one event Trials licences will hopefully join an ACU Club, take out a full Trials Registration and become an ACU Trials Registered Rider.

The cost of the One Event Trials Registration is £3.00. The One Event Trials Registrations are available in books of ten, ie. £30.00 for a book. It should be noted

by Organisers that the One Event Trials Registrations won't be available for purchase individually – only in books of ten. Organising Clubs are to pay for the books at the point of purchase, ie. there is no credit facility. Once the books are sold, the Club keep the money to recoup the expenditure they outlaid at the point of purchase.

To summarise – The books themselves consist of ten one event Trials Registration forms. There are no counterfoil or copies of the Registration forms – just ten Registrations. The Club buys the book in advance for £30.00, sells the Registrations at £3.00 each and keeps the money to reimburse their initial outlay. There is nothing to send back to ACU Head Office, no money and no counterfoils of the Registrations sold.

Associate membership

Associate Membership is available to any individual who does not hold a current

Competition Licence/Registration. The annual fee of £10.00 allows the individual to enjoy a range of benefits and discounts that have been secured by the ACU for its members.

Benefits include significant discounts on a range of motorcycle related products as well as travel and accommodation. To view an up to date list of benefits please visit the ACU website.

ACU Benevolent Fund

ADMINISTRATIVE COMMITTEE

For contact details please refer to the Committees and Panels section.

R. Hanks (Chairman)

Mrs M. Carter JP (Treasurer) **Mr C.**

Pattison Mrs J. Macphee **Mrs W. Evans**
MBE

Mrs L Francis

Mr E Nelson

Trustees: Mrs M. Carter JP, Mrs W. Evans MBE,

Mrs L Francis, R. Hanks, Mrs J. Macphee,

Mr C Pattison.

It is first of all most essential to establish that the ACU Benevolent Fund is not a form of insurance. It is a registered charity that endeavours to give assistance to past and present members of the ACU including their family and dependants who are suffering financial hardship howsoever caused. No one has an automatic right to expect assistance.

Every competitor should be aware that due to the present limitations on accident insurance cover in respect of injuries it is now even more important to consider making alternative arrangements to provide their own personal cover in the event of an injury.

Areas the Ben Fund may be able to assist with is in the initial period when help is needed following an accident or injury prior to any state benefits being made available, also consideration will be given to help with travel costs when someone is hospitalised some distance from home.

Any request for help should be made via your own Benevolent Fund Officer as listed over the page or direct to the Ben Fund Secretary

at the Rugby Office. A standard form will be supplied asking for certain details which should be completed as fully as possible at the time and returned to either your local Ben Fund Officer or the Rugby Office. All requests for assistance received and any information given is completely confidential and will never be divulged to any other person or body.

The Trustees of the Fund will always give very sympathetic consideration to all requests for help. Our funds are however restricted and

rely almost entirely on the generous financial help of our clubs, centres and other supporters, without this we would not be in a position to carry out our work of giving help and support where needed. If the Benevolent Fund has been able to help you in the past why not contact your local club or centre and offer your assistance in helping to raise funds for the future.

The Trustees recognise and appreciate the generous support of the Auto Cycle Union.

During 2019 the Benevolent Fund has seen voluntary donations remain steady for which we are thankful. Requests for help remain high and in relation to the donations were at times only just breaking even. It has been possible to build up a small reserve over the past few years and this reserve is now being used to continue the work of helping those in need. However, reserves do not last forever, we therefore have to request that in order to continue to give help where needed we must find ways of increasing our donations. The ACU Benevolent Fund is not a HIGH PROFILE CHARITY, as our help is restricted to past and present members of the

ACU and their families, it is therefore only right that the majority of our income is self generated as it has always been in the past.

To our many Centres, Clubs and general supporters that have been the backbone of our income in the past we give you our most sincere thanks, what we now have to ask is that in order to maintain our level of support to those in need, we need the help of those who have perhaps left it to others in the past. The families of those we help over the years are possibly members of your Centre or your Club please help us to continue helping them.

In the year ending 31st December 2019 the grants will exceed £90,000.

To all our many supporters our sincere thanks for providing us with the means to continue our work.

BENEVOLENT FUND OFFICERS

Cheshire & North Wales Mrs L Francis.

Tel: 0151 336 4940 Mob: 07753 742911
lyn.francis18@gmail.com

Cornwall Chris Tyrrel, Kangan Farm, Criggan, Bugle, St Austell, PL26 8QX. Tel: 01726 890404 christ6996@hotmail.com

Eastern Debbie Blyth. Tel: 07963 118917 blyths21@hotmail.com

East Midlands Mrs A. Boyle, 126 Uttoxeter Road, Hill Ridware, Rugeley, Staffordshire WS15 3QX. Tel: 01543 492212 Mob: 07866 605082
annie126@outlook.com

East South Wales Mr D. Smith, Crosswinds, 13 Julians Close, Gelligar, Caerphilly, CF82 8DT Tel 01443 556407

East Yorks Mrs E. Race, 20 Broadlands Drive, East Ayton, Scarborough, North Yorkshire YO13 9ET. Tel: 01723 863987 erace@hotmail.co.uk

Isle of Man Mrs W. Evans MBE, 3 Mount View Terrace, Onchan, Isle of Man IM3 1AB. Tel: 01624 621296/07624 433540
acubenfundiom@manx.net

Midland Mr & Mrs G. Daniel, 25 Doidge Rd, Erdington, Birmingham B23 7SQ. Tel: 0121 350 2601 (Eve) 0121 373 1035 (Day)
gerrydan@blueyonder.co.uk

Mid Wales Mr M. Bates, Nant-yr-Wyn, Llanbister Road, Landrindod Wells, Powys LD1 5UP. Tel: 01547 550393

Northern Mr K. Quinn, 7 Arkholme Close, Carnforth LA5 9XF. Tel: 01524 732089

North Eastern Mr J. A. Guthrie, 9 Hillside Gardens, Sunderland, Tyne & Wear SR2 9AR. Tel: 0191 522 6260
guthaz@ntlworld.com

North Western Mr Adrian Brown, 20 Albany Drive, Walton Le Dale, Preston, Lancashire, PR5 4TY. Tel: 07863 557183
adrian@deklanbrown.com

South Eastern Centre Mrs Hazel Collins, 14 Brookside, Calcot, near Reading, RG31 7PJ. Tel: 01189 421534
rhaze@talktalk.net

Southern Mr T. Graves 13 Locksley Road, Eastleigh, Hampshire, SO50 5DX. Tel: 02380 643503/075868 07927

South Midland Mr D. Porter, 22 Belper Road, Luton, Beds, LU4 8RG. Tel: 07710 435127
david.porter31@btinternet.com

South Western Mr C. Pattison, 6 Churchfields, Wincanton, Somerset BA9 9AJ. Tel: 01963 33001

Wessex Mr M. Bracey, 3 Burden Close, Bradley Stoke, Bristol BS32 8BL. Tel: 01179 236867/07889 363526
martinjan@talktalk.net

Western Mr Tom Vivian, Blakes Lane, Guarford, Malvern, WR13 6NZ. Tel: 01684 311585 vivians@themail.co.uk

West South Wales Mr Bryan Puckett, 32 Heol Derwen, Cimla, Neath, SA11 3YS. Tel: 01639 767851
bryan.puckett@btinternet.com

Yorkshire Mrs M. Carter JP, 10 Byeway, Guiseley, Leeds LS20 8JP. Tel: 01943 878666
mcarterhuntersgap@btinternet.com

Scottish ACU Mr Charles Mackenzie, 28 West Main street, Uphall, West Lothian, EH52 5DW. Tel: 01506 858354
office@sacu.co.uk

price List

Payable to the Auto Cycle Union Ltd.

PERMIT FEES (INC VAT) (ISSUED BY HEAD OFFICE)

INTERNATIONAL

(excluding FIM Inscription Fee)

Speed Events, all Stadium Events and Hare & Hounds Events	£300.00
Trials and Enduro	£75.00

FIME CONTINENTAL & NATIONAL

Speed Events, all Stadium Events

ALL OTHER PERMITS BELOW FIME CONTINENTAL AND NATIONAL ISSUED BY HEAD OFFICE

Speed Events, all Stadium Events and Hare & Hounds Events	£50.00
Trials, Enduros, Road Rallies	Contact ACU
Test Days	£50.00

SOCIAL GATHERING PERMIT

	£35.00
0	

RECORD ATTEMPTS (HELD IN UK)

Per Meeting/Day	£35.00
0	

COACHING & PRACTICE

PERMITS Contact ACU office for details

BIKE TRIALS

	£15.00
0	

YOUTH PERMITS

International	£50.00
0	
FIME Continental, National and National Restricted	£25.00

PROTEST FEES

International	Competition
0	£150.00
Competition	National/Restricted/Closed
£100.00	Engine Measurement & Fuel Testing charges
<i>can be found in discipline regulations and Fuel Regulations within this Handbook.</i>	

AppeAL FEES

To the Final Tribunal of Appeal	£5000.00
Competitors first appeal to FTA	£500.00
Licensed Officials first appeal to FTA	£500.00
0	
To the Auto-Cycle Union	£300.00
To the ACU Local Centre	£150.00
All other Youth Permits issued by Head Office	£10.00

International Events	
Off Road (Trials, Enduro, Motocross, Track Racing etc)	£1
50.00 Road Racing	£2
00.00	

FINES

Levied by ACU Court	Unli
Levied by National Club, Centre or Stewards	Maximum
£500.00 Levied by Clerk of the Course	Maximum £500.00 Non
production of licence	£10.00

Basic Permit Insurance Package	
1 day	£500.00 (only permit element inc VAT)
2 days	£700.00 (only permit element inc VAT)
Practice Day Permit held under Basic Insurance	£440.00 (only permit element inc VAT)

CLUB AFFILIATION FEES (pER ANNUM)

Less than 50 registered members	£10.0
0 Between 50-99 registered members	£20.0
0 Between 100-199 registered members	£40.00
200+ registered members	£50.0
0	

ADMISSION TICKETS

per 1000 incl postage per roll £11.00 + VAT

MARKER TAPE

Blue logo per roll 500m	£12 + VAT + Postage
White logo per roll 500m	£10 + VAT + Postage

WARNING NOTICES

All items plus VAT & Postage	Paper Correx
Type A (<i>Motor Sport Can Be Dangerous</i>)	£2.00 £5.00
Type B (<i>Prohibited Area</i>)	£2.00 £5.00
Type C (<i>Warning Notice</i>)	£2.00 £3.50

LASU

The ACU's Local Authority Support Unit (LASU) was launched in January 2005 with funding from Motorsport Development UK (MDUK). Its remit is to offer assistance to Local Authorities, Police Forces and other interested parties who are experiencing problems as a result of illegal off road motorcycling.

The main issues facing Local Authorities are the social disruption and safety concerns caused by the inappropriate and often illegal use of motorcycles in public areas. These problems have been exacerbated by the effects of increased popularity for the activity coupled with a lack of provision throughout the country. Local Authorities, Police Forces and communities are faced with two options to deal with the problem:

1. Police the issue away with enforcement
2. Organise well planned provision, with targeted enforcement

The first option, policing the issue, is often

seen as the best solution but has, in the past, simply moved the problem elsewhere, only to see it return to a community over time.

LASU believes that providing a legal and safe place to ride with targeted enforcement is the best solution. By contacting LASU, Local Authorities and Police Forces have access to professional assistance to identify the type of problem, its size, nature and location as well as receiving help to create a workable solution.

For off road problems, LASU can provide assistance with the following issues:

- Feasibility Studies
- Land Access and Planning
- Course and Venue Design
- Insurance
- Environmental Issues
- Noise Monitoring and Testing
- Training of Officials, Marshals and Coaches
- Codes of Best Practice
- Creating Community Projects
- Practice Tracks

The mechanism LASU can deliver is extremely cost effective when compared to costs incurred by Local Authorities and Police Forces in enforcement. In addition, it provides young people with a chance to enjoy their motorcycling

environment, safe from prosecution and bike seizure.

For more information on Off Road Provision, please contact LASU Secretary: Debbie Walmsley. Tel: 01788 566419 dw@acu.org.uk

2019 REGISTERED OFF ROAD PROJECTS

- Bromley Beacon Academy, Kent, contact Daniel Matellis. Tel: 07904 590608
- Bridge Centre Project, East Lothian. Tel: 01620 829817
- MX Challenge Project, Dover. Tel: 01304 202244

2019 MINI BIKE PROJECTS

- Bikewise Mini Bike Club, Durham, Gary Ward via Debbie Walmsley. Tel: 01788 566419 dw@acu.org.uk
- Gloucestershire Youth Mini Bike Project, contact Mark Jones. Tel: 01452 833227

mark.jones@gloucestershire.pnn.police.uk

Training Department

The ACU Training Department is responsible for the training of anyone wishing to become an ACU Certified Coach.

The Training Secretary maintains an up to date Register of all ACU Certified Sporting Coaches in all disciplines of motorcycle sport. She also manages the renewal process for coaches and the yearly seminars that all coaches must attend at least once every three years, in order to keep their Certification current.

COACH TRAINING

The ACU Coach Certification Programme is open to anyone who wishes to coach sporting motorcycle skills.

The ACU Coach Certification Programme delivers training and assessment that is mapped to National Coaching Standards, providing new and existing coaches with the fundamental skills needed in order to pass on their skills and knowledge to other riders.

The ACU has three categories of Coach:

ACU Club Coach – for anyone who wishes to coach at club level, on a voluntary basis. Applicants must be competent riders, fully conversant with all appropriate riding skills for the discipline in which they wish to coach. Applicants may be asked to undertake and pass a test of riding competency before coach training commences. Training for this certification is FREE of charge for a member of an affiliated ACU Club (subject to approval from the Club/ Centre) with an annual Coach Certificate fee of £25.

ACU Project Coach – for people who coach for Local Authority or Community/ Charitable Motorcycle Projects. Applicants must be competent riders, fully conversant with all appropriate riding skills for the discipline in which they wish to coach. Applicants may be asked to undertake and pass a test of riding competency before coach training commences. A subsidised charge is made for the training of this type of coach and the annual Certificate fee is £35.

ACU Commercial Coach – for anyone with background in motorcycle sport who wish to provide coaching for a fee. Applicants

must be able to provide proof of a satisfactory standard of riding ability. A full list of acceptable minimum standards is included in the application paperwork.

Commercial coaches can also coach at Club and Project level. The training of Commercial Coaches is charged at a commercial rate and the annual Certificate fee is £84 including VAT.

All coaches must undergo a DBS check (previously called a Criminal Records Bureau check).

There are 3 levels of ACU coach. Any Coach wishing to progress to Level 2 or 3 should contact the Training Secretary for further information.

Shaun Brown, who has a vast wealth of experience as a Road Race competitor and Coach, has been appointed as the ACU Sports Development Officer and Shaun can be contacted via Debbie Walmsley, the Training Secretary as follows: tel: 01788 566419 email: dw@acu.org.uk.

LARA

LARA is the motoring organisations' Land Access and Recreation Association and acts as a national forum for the principal groups in countryside motor sport and recreation. LARA does not organise events or act as any sort of governing body, but it does assist its members in a wide range of land access issues: policy, practice and problems. If you want to know more about motor sport and recreation – how to take part, land access issues, planning problems, etc. – then either LARA or one of its member groups probably has the answers you seek.

You can contact LARA at admin@laragb.org on any ACU-related matter involving land use, including planning permission issues, conservation designations, and public rights of way. LARA may not have the answer to all questions, but can usually point you in the direction of somebody who knows.

THE DRIVERS' & RIDERS' COUNTRYSIDE CODE OF CONDUCT

1. Use only Vehicular Rights of Way – not all green roads have vehicular rights. LARA groups can help with information.
2. Keep to the defined track, and deviate only to pass immovable obstructions. Report obstructions, including low branches and very soft ground, to the highway authority. If the correct route is not obvious on the ground, ask local users, or check the details held at highway authority and local record offices.
3. Travel at a quiet and unobtrusive pace, alone or in small groups. Remember that others seek to get away from bustle.
4. Ensure that you and your vehicle are fully road legal, and obey traffic and LARA signs. Green roads are subject to the same laws as surfaced roads. There is no public right to drive away from a road on common land, moorland, sand dunes, or beach.
5. Pay attention to 'the Four W's'
 - Weather** – Do not travel on green roads when they risk being damaged beyond a point of natural recovery when the weather improves.

Weight – Do not use the roads which may be seriously damaged by the wheel pressure of your vehicle. LARA does not support use of heavy vehicles on green roads.

Width – Do not use roads which are too narrow for your vehicle. Avoid damage to trees, hedges and boundaries.

Winches – Only use when unavoidable. Always avoid damage to trees, walls, and surface while recovering.

6. Respect the life of the countryside. Be courteous to all other users, and take great care when passing horses. Be prepared to stop your engine if needed. Always fasten gates and take care near livestock.
7. Remember that wildlife faces many threats and green roads can be valuable habitats. Take special care in spring and early summer.

THE ACU COMPETITIONS NOISE CHARTER

- a) Do ensure that your vehicle complies with the noise limits applicable to the event.
- b) Do not continue competing with a defective or damaged exhaust system. Remember that you will be excluded from an event if you continue in spite of an excessively noisy exhaust.
- c) Do not rev the engine needlessly in service areas, paddock, and start areas, etc.
- d) Do respect official instructions in respect of quiet zones.

ENVIRONMENTAL POLLUTION

- a) Do ensure that your vehicle is free from leaks of oil and other fluids which may not only present a hazard to yourself and others but also contaminate the countryside.
- b) Do not carelessly spill fluids nor discard used, broken components. Always properly dispose of all waste materials.
- c) Do not drop litter, take it home.

RESPECT

- a) Always respect officials and their instructions, they are for a purpose and your benefit.
- b) Do not be abusive towards officials this is

bad manners and carries extreme penalties which might shorten your sporting career.

- c) Always respect other users and the public in general, however abusive or obstructive.

Let the officials deal with such problems, and do not make them worse.

ACU REGIONAL SPORTING OFFICERS

Eddie Jones 18 Chapel Street, Astwood Bank, Redditch B96 6DA. Tel: 01527 893392/07947 319432

Anthony Kenny 250 Point Clear Road, St. Osyth, Clacton on Sea, Essex CO16 8JL. Tel: 01255 820295

Bryan Puckett 32 Hoel Derwen, Cimla, Neath, West Glamorgan SA11 3YS. Tel: 01639 767851

Barry Robinson 9 Melville Grove, Ilkley, Yorks LS29 8NX. Tel/Fax: 01943 609722

David Smith 20 Chedworth Drive, Witney, Oxon OX8 5FS. Tel: 01993 708418 (7-9pm only).

Cass Edward 157 Queens Walk, Woodston, Peterborough, PE2 9AJ. Tel: 07933 777209

The ACU Regional Sporting Officers provide a local source of advice and information on all the above and represent both car and motorcycle interests. If you would like to assist the ACU

in its fight to protect the rights of motorsport, by becoming a Regional Officer would you please forward your brief details to the ACU Office. Make no mistake, the full might of the environmental lobby is now being ranged against motorsport. Despite having organised responsible events for nigh-on 100 years our clubs are losing venues hand-over-fist through no fault of their own.

ACU needs more regional officers to help co-ordinate the fight back

Land Use Advisory Service

Planning, conservation, rights of way, open access and noise are all potential problems which can affect and frequently have affected clubs staging off-road motorcycle sport at local or even national level. As a result, the Land Use Advice Service (LUAS) has been set up to help find satisfactory resolutions.

LUAS will help clubs with problems specific to sites and events. Email or telephone advice will be available when a problem arises, and each issue will be documented as a 'case file' at ACU Headquarters. This is very important as experience shows us that having the 'full story'

- all the correspondence and the site's history

- is crucial to a successful outcome, and once a particular problem is wrapped up, LUAS will look at it to see if there is a learning experience that should be written up as advice for the benefit of other ACU clubs. This is not more paperwork for its own sake: the level of official control and intervention in all aspects of land use goes up and up, and motorcycle sport now, more than ever, has to work within the system.

The ACU has engaged Alan Kind, who also works on planning issues for LARA, as its specialist officer to provide both general and case-specific advice. Clubs with problems can certainly speak directly with Alan, but LUAS has to manage all its communications carefully, so initial contacts should be via Debbie, please. Alan is updating a set of Guidance Notes covering topics which regularly come up, such as 14/28 day rule (concerning the need for planning permission) and how to set about getting local authority authorisation for trials on

public rights of way. Please visit LARA's website laragb.org.

LUAS is here to help the ACU's clubs, but it is not a one-way process – you cannot always ask for, and get, a packaged solution to your problems. Headquarters needs the clubs to work with LUAS so that, in the future, few if any problems arise and motorcycle sport is regarded as a good and welcome neighbour in the countryside.

If you have a problem, or just want to know more about any particular topic, then your first point of contact is Debbie Walmsley at ACU Headquarters (Tel: 01788 566419 or email: dw@acu.org.uk).

The Motor Vehicles (Off Road Events) Regulations 1995

DANGEROUS, CARELESS AND INCONSIDERATE RIDING – APPLIES NOT ONLY TO THE PUBLIC HIGHWAY.

From 1 July 1992, the offences of dangerous, careless and inconsiderate driving of a mechanically propelled vehicle on the road (sections 1, 2 & 3 of the 1998 Road Traffic Act as amended by the RTA 1991) have also applied to a Public Place. This change was driven by the absence of effective legislation to control illegal driving by underage drivers in public places which are not necessarily a public road.

This extension of road traffic law to public places had far reaching consequences for those who take part in or organise events involving motor vehicles in fields, parks or other areas where the general public is admitted either free of charge or on payment of entry fee. Consequently provision was made in the legislation in order that the legislation does not apply to those taking part in 'authorised' motoring events when driving in a public place other than a road, provided they are driving in accordance with the appropriate authorisation for the event. Consequently, in most instances it is anticipated that ACU licensed riders participating in ACU authorised events will have nothing to fear.

It is not illegal to organise or take part in an unauthorised motoring event in a public place, but drivers and riders should be aware that they are liable for prosecution if in doing so they drive dangerously or carelessly. It should be assumed that what may be regarded as fair competitive riding on a race circuit may be regarded as dangerous or careless in an unauthorised place.

Consequently, any rider who may be attracted to ride in any other events should ensure that the events are authorised in accordance with the Motor Vehicles (Off Road Events) Regulations 1995. The responsibility for ensuring that an event is authorised lies equally with riders and organisers.

The precise definition of 'event' or 'public place' cannot be given. Authorising Bodies have

to consider whether the event requires drivers/ riders to drive/ride dangerously.

NAVIGATIONAL SCATTER EVENTS

The Motor Vehicles (Competition and Trials) Regulations 1969 is specific legislation governing motoring events held on the public highway.

The Road Traffic Act makes it illegal to race or trial of speed on the public highway, unless it is of a sort permitted by the 1969 legislation and authorised in accordance with it. It is legislation which makes it illegal to run a treasure hunt

of more than 12 vehicles, unless a specific authorisation permit is obtained. The authorisation procedures are quite involved and can be expensive to administer. However, a Navigational Scatter Event is considered to be automatically authorised so long as it conforms to these various conditions:

- Regulations/information sheet should clearly state the type of event, along with an estimate of the mileage likely to be covered.
- The places to be visited must be detailed to the competitors by way of points on a map, or on a list. However, there **MUST BE NO REQUIREMENT** for the control points to be visited in any specific order.
- Competitors should be given random choice of points to visit, and not be required to visit more than 75% of them.
- The control points should be safely positioned so that there is no danger to either riders or the general public. Paying special attention to traffic speed at, pull-off points, advanced signing, parking, number of riders that may be at any one control point at any time, access to private land, vicinity of house, noise levels, church service times, other events which may be taking place in villages on route at the same time (funerals, carnivals, garden fetes etc.).
- Competitors must be free to visit control points in any order.
- Riders should be obliged to get off their bikes to reach the actual control point.
- No form of timing should be employed

on the public highway sections, although a finish time may be specified providing it gives reasonable and adequate time to visit the required number of control points.

pOLICE

Although there is no requirement to notify the police, it is wise to do so by simply sending the police authority/ies through which your event runs, a copy of a publicity sheet, or event diary, highlighting the date and location of checkpoints, and mark it "for information only".

INSURANCE

Where any part of an event takes place in circumstances where the Road Traffic Act applies, i.e. in a public place, competitors must be covered by their own Motor Insurance Policy. Most organisers understand that if someone is injured or damage is done to property as a result of acting negligently an action for compensation may be brought against them. The ACU will provide a permit and insurance cover to clubs in order that officials and members may be safeguarded against legal liability as much as possible. If organisers don't currently carry cover, then please obtain details of the ACU's Clubs Insurance Scheme and make use of it.

ACU Environmental Code

1. INTRODUCTION

The realisation that society is rapidly destroying natural resources and polluting the environment to meet its own needs has now spread from pressure group thinking to the mainstream. In particular, increasing attention is now being paid to the concept of sustainable development that meets the needs of the present generation, without compromising the ability of future generations, to meet their own needs.

All activities have an impact on the environment, through the resources they use, the processes they undertake, and the waste created. Pressures to change our way of operating are now being brought to bear on all types of sport and recreation.

The governing body of motorcycle sport at both National and International level has two objectives to achieve in developing an Environmental Code.

- i) To ensure that it manages our activities in a way that is sustainable within the environment.
- ii) To put itself in a position where it can demonstrate to Local and National Governments that it is a responsible member of the community, with both the ability and willingness to contribute to the protection of critical aspects of our environment.

2. GENERAL PRINCIPLES

- 21 Motorcycle activities fall clearly into three main categories: competitive sport, recreation, and transport.
- 22 Motorcycle sport is a major constituent of the International and National sporting calendars, attracting an ever-increasing audience and producing significant economic benefits. It is a sport that, like most other sports, and human activities in general, creates an impact on the environment.
- 23 Motorcycle riding, as a means of transport or recreation, continues to increase and, therefore, should also be looked at from an environmental point of view.
- 24 The ACU considers it to be of major

importance to develop a coherent environmental policy, taking into account the legislative and regulatory requirements of the United Kingdom, and the European Community.

- 25 The ACU environmental policy, as defined in this Code, is based on mutual respect for the needs of the environment and for the reasonable practices of motorcycling in general.
- 26 The ACU seeks to co-operate closely with all appropriate organisations in order to ensure that motorcycle activities are, at all times, environmentally acceptable.
- 27 The ACU shall adapt its Rules and Standing Regulations in order to give proper recognition to environmental matters and to the principles of the Code.
- 28 According to the above General Principles, this Code seeks to improve the relationship between motorcycling and the community at large. These main principles refer, in particular, to:
 - a) noise, fuel, protection of the ground, and cleaning issues;
 - b) behaviour of all persons, either directly or indirectly, involved in motorcycling.
- 29 The ACU will seek to establish, at all times, the appropriate environmental standards during the organisation of motorcycle events, at all levels, and will promote environmental consciousness.
- 210 In order to ensure that this Code is respected, the ACU has added environmental responsibilities to the duties of the Clerk of the Course.

3. ENVIRONMENTAL

RESPONSIBILITIES At each event the Clerk of the Course is responsible for all environmental issues associated with that event. The Clerk of the Course can delegate the duties (but not the responsibilities) to another suitably licensed official appropriate to the status of the Event. (i.e. An official with a National Track Racing Clerk of the Course Licence can undertake the Environmental Duties at a National Motocross Event).

The Clerk of the Course will:

- Ensure that the ACU Environmental Code is respected.
- Have access to all information relating to the event and must be able to, prior to, during, and after, the event, take appropriate action or make recommendations on all aspects of the event which may have environmental consequences.
- Report to the Stewards of the Meeting on environmental aspects of the event, and make recommendations to the Stewards or the Sustainable Events Management Panel on issues which may have future environmental consequences.

For International Championship Events, these responsibilities must be undertaken by an official in possession of a current FIM Environmental Officials Licence as specified in the FIM Sporting Code.

4 SOUND

4.1 MOTORCYCLES – INDIVIDUAL

- Avoid all unnecessary running of engines.
- Respect any agreed sound level restrictions.
- The sound levels, in all disciplines, must comply with the particular discipline's Standing Regulations.
- The ACU maximum sound levels for all disciplines will be enforced, controlled by licensed officials with approved equipment. For details, which vary slightly between disciplines, refer to the sporting and Technical rules.

4.2 MOTORCYCLES – COLLECTIVE

- Adequate consideration must be given to the siting of the course, and in particular the start areas, in relation to local residential properties.

4.3 COMMUNICATION

- Separate address systems for riders' paddock and the public area are preferable.
- Position of loud-speakers: to ensure that sound pollution is prevented outside the venue.
- Maintain the sound level as low as possible and ensure that sound levels do not exceed 85 dB/A in areas accessible to the public.
- A public address system can cause more annoyance outside the track than the actual sound of motorcycles. Make arrangements

with the people in charge of the system to reduce the sound volume to an absolute minimum between races/practice sessions.

5. FUEL

- It is a requirement that commercially available unleaded fuel, without additives, except oil for two stroke engines, is used.
- For Track Racing, the use of methanol is permitted.
- The use of alternative fuels which are more environmentally friendly, when sanctioned by the appropriate sporting regulations, are permitted.
- Fuel tests are carried out in accordance with the procedure laid down in the Technical Rules.
- Samples of the test are sent by the organisers of the event to a laboratory selected by the ACU.

6. PROTECTION OF THE GROUND

- Measures must be taken to prevent discharges of fuel, oil, cleaning fluids, degreasants, cooling and brake fluids, etc. into the ground. For all off-road disciplines, competitors are required to use an environmental mat at all points where machines are serviced.
Specification of Environment Mat
Dimensions 160cm × 100cm (Track Racing Solo – 160cm × 75cm)
Absorption Capacity Minimum One Litre
 The Environment Mat must be composed of an absorbent upper part and an impermeable lower part.
Thickness Minimum 5mm
- Environment mats must also be placed under mobile generators and oil/fuel storage facilities to avoid pollution of the ground.
- Containers/facilities to recover catering waste, used rags and oil filters, waste oil and coolant must be provided by the organisers.
- Leave no long-term evidence of any activity.

7. CLEANING OF MOTORCYCLES

- Cleaning of motorcycles can only be carried out at places designated by the organisers.
- No detergents are permitted.
- Cleaning facilities must be constructed and managed to avoid pollution of the ground.

8. ACTION TO BE TAKEN BY COMPETITORS

- Each competitor is responsible for the waste generated by his team during the event.
- Where organisers provide the necessary containers for waste they must be used as directed.
- Waste must be retained by the team until the approved facilities provided by the organisers can be used.
- Used tyres must be retained by the rider unless storage and disposal facilities are provided by the organiser.
- Where refuelling or servicing of a motorcycle is being undertaken at an off-road event, competitors must provide and use an environment mat to protect the ground. These mats must be removed by the competitor after use.
- Where organisers or competitors provide generators powered by petrol or diesel engines, they must be placed on an environment mat, and that mat must be removed by the user afterwards.
- Any infringement by the competitor of the ACU Environment Code can result in disciplinary action being taken.

9. ACTION TO BE TAKEN BY ORGANISERS

9.1 EVENT ENVIRONMENT MANAGEMENT PLAN

This plan must include at least the following points:

- a) An assessment of the environment impact of the event on the paddock, start area and the entire course and its surroundings, having regard to the number of competitors and the expected number of spectators.
- b) Provision of adequate and appropriate direction signs to the event which must be removed within 24 hours of the event. Do not allow parking on vulnerable areas (verges, green lanes, etc.), or where soil damage may occur (eg after heavy rain). Where large numbers of spectators are envisaged consultation with the Police is recommended.
- c) Measures taken to prevent the pollution of streams where used as a drinking source for either animals or humans.
- d) Provision of a machine cleaning area in

accordance with the appropriate discipline regulations for events where the cleaning of motorcycles is permitted.

- e) Provision of Containers for used oil, brake fluids and cooling fluid or any other liquid. These may be a requirement of the sporting discipline. Where required they must be clearly marked "waste oil only" and have an opening sufficiently large to avoid spillage and a captive funnel.
- e) Ensure that all fuel and waste oil, and all generators are placed on an environment mat. Provide containers for oil filters and cleaning rags.
- f) Provision of sufficient containers for competitors and spectator's general litter. Consideration to be given to providing competitors with a rubbish bag on arrival and instructions on what to do with it.
- g) Provision of Sanitary facilities. Further guidance on numbers is provided on page 84.
- h) Judicious positioning of any loudspeakers.
- i) Where a central refuelling point is provided, ensure that motorcycles are only refuelled when parked on an environment mat. Provide Fire Extinguisher and have it clearly signed. Display No Smoking signs

9.2 INFORMATION TO THE SPECTATORS

- Inform the public about responsible behaviour on the site
- Request spectators to use the rubbish containers provided.

9.3 AFTER THE EVENT

- Signposts, billboards and posters must be removed immediately after the event.
- Clear away tapes and markers around the event site.
- The event site must be returned to its original condition as soon as possible.
- Arrange for prompt removal of all waste and rubbish.
- Ensure that the disposal of medical or other hazardous waste is managed by specialist companies.
- Remove mud from public highways and remove direction signs etc

9.4 PUBLICITY AND ADVERTISING

- Place billboards and posters only after

having obtained permission from the owner of the property, and the local highway authority if appropriate.

- Take Government regulations into account when positioning billboards.
- Do not distribute leaflets/pamphlets under windscreen-wipers of cars, on motorcycles, nor to spectators (do not allow others to do so during an event).

10. RECOMMENDATIONS FOR ROAD USERS

10.1 RIDER CONDUCT

- Individual motorcyclists should develop riding habits to ensure full integration with other types of users.
- Ride safely and avoid aggressive and competitive riding.
- Save petrol and reduce pollution by avoiding unnecessary idling of engines.
- Ride politely and limit noise pollution by using your horn only in an emergency.
- Noise annoys. Use a legal exhaust system and keep audio systems at a low level.
- Use only routes which are legally available to motorcyclists.
- Ride responsibly at all times.
- Respect nature by not travelling on routes that risk being damaged beyond a point of natural recovery.
- Protect wildlife and its natural habitat by riding intelligently.
- Take responsibility for ensuring that your used oil, tyres, batteries and other recyclable items are properly disposed of.
- Encourage fuel efficiency and space economy by riding motorcycles instead of driving automobiles.

AppENDIX A Recommended standards for the provision of sanitary facilities at ACU events

1. pROVISION FOR RIDERS/ pARTICIPANTS

As specified in the rules for each discipline.

2. pROVISION FOR SpECTATORS, ETC. FEMALE

- 1 WC per 100 or fewer females who it is anticipated will attend.

MALE

- 1 WC per 100 or fewer males who it is anticipated will attend.
- 2 WC per 100–500 males who it is anticipated will attend.
- 1 additional WC for every additional 500 males who it is anticipated will attend.
- 1.5 metres of urinal facility for every 500 males.

3. DURATION

For events lasting for less than four hours, this standard can be reduced by 25%.

4. MAINTENANCE

These facilities must be maintained in a clean condition and kept fully supplied for the duration of the event.

5. WASH BASINS

Should be provided in the ratio of 1 per 5 sanitary facilities

6. DISABLED pEOpLE

One of the facilities, in each separated spectator area, should provide for wheelchair users.

Equal opportunities/sports equity policy statement

- The Auto-Cycle Union (ACU) aims to ensure that all people irrespective of their age, gender, disability, race, ethnic origin, creed, colour, social status or sexual orientation, have a genuine and equal opportunity to participate in motorcycle sport and leisure at all levels and in all roles. That is as a beginner, participant or competitor, and as a coach, manager, administrator, official or spectator.
- It is the aim of the ACU to ensure that all present and potential members/employees of the ACU receive equal and fair treatment.
- It is the aim of the ACU to provide all its services in a way which is fair to everyone.
- It is the aim of the ACU in its relationship with its members/employees and in its provision of services not to disadvantage any individual by imposing any conditions or requirements which cannot be fully justified.
- In pursuance of this policy the ACU may take special measures/positive action for any group which is currently under-represented in its membership, representative bodies or workforce, taking account of the Race Relations Act (1976) and the Sex Discrimination Acts (1975, 1986).
- In pursuance of this policy the ACU reserves the right to discipline any members/employees of the ACU who practice any forms of discrimination on the grounds of a persons age, gender, disability, ethnic origin, creed, colour, social status or sexual orientation.
- The ACU will monitor and evaluate this policy on an ongoing basis and will inform the members/employees of its impact.

DISABILITY pOLICY STATEMENT

- The Auto-Cycle Union has a policy of encouraging and supporting the motorcycling ambitions of anyone with a disability making motorcycle sport an activity that is genuinely open to anyone who wishes to take part.
- The ACU has a framework of requirements and assessments to ensure that everyone can enjoy the sport, in whatever capacity and to whatever level they are capable.

Insurance

The following policies have been arranged to protect Auto Cycle Union Ltd (ACU), ACU Events Ltd, ACU Events (Isle of Man) Ltd and Auto Cycle Union (ACU) and/or their affiliated clubs or any local Association or Organisation approved by the ACU and their Officials in addition to "signed-on" Competitors who are members of the ACU but only when an ACU permit or certificate of exemption has been issued for the event. An event can comprise Practice or Competition. The policies arranged by the ACU are:

- Public Liability for injury or damage to other people or property (see exclusions and limitations on the following page)
- Personal Accident to Officials
- Personal Accident to Competitors or participants (Premier Cover only)
- Road Traffic Act Liability

The benefits noted in this section only apply to events permitted by ACU Ltd or ACU Events Ltd.

The policies are arranged through Lockton, 1st Floor, 3 Piccadilly Place, Manchester M1 3BN. Tel: 0161 828 3343 Fax: 0161 828 3335

christine.hare@uk.lockton.com and copies of them may be seen by arrangement with the General Secretary at ACU House, Wood Street, Rugby, Warwickshire, CV21 2YX.

A table of Benefits for Competitors and Officials appears later in this Section.

PUBLIC LIABILITY COVER

Any person allegedly injuring another or damaging another person's property may have an action for compensation brought against them. This is as true of motor sport activity as of any other and it is for this reason that the ACU has arranged Public Liability insurance to protect its Affiliated Clubs, Local Centres, Officials, Sponsors and others who are involved in organising or running ACU permitted events. For these potential legal liabilities to be covered under the ACU policy, the Organisers must obtain an appropriate Permit or exemption from the ACU.

The indemnity limit for any one accident is £40 million under Premier cover and £10

million under Basic cover. The cost of defending Organisers and their Officials against allegations that might become the subject of indemnity under this insurance (including prosecution by the Health and Safety Executive) is also met by the Insurers subject to them taking over the conduct and control of any such defence.

The cover applies to associated activities necessary to an event such as setting up and dismantling a course.

Training days are covered subject to prior notification, approval of procedures and issue of a Training Permit, by the Training Department after payment of the appropriate fee. A per capita charge may be made for insurance cover provided.

Non motorcycling social events run by clubs affiliated to the ACU are included in the cover, i.e. club nights and the like (excluding fireworks).

The Policy extends to protect all persons appointed to act as an Official of any permitted event in respect of their third party liabilities arising from their official duties, subject to the terms, conditions and exclusions of the Policy.

LANDOWNERS

The ACU and its members need to retain the goodwill of Landowners so that land continues to be made available for events. For this reason the ACU policy indemnifies Landowners in respect of their potential legal liability to third parties following an accident in connection with a permitted event for which they have made available the use of their land. The indemnity protects them against being drawn in to a claim if there is an accident during the event and also indemnifies the Landowner if an allegation is made that cause of injury or damage was due to some defect in the Landowner's premises. The amount of Indemnity provided depends on the cover selected by the Organisers of the event.

Many Landowners expect that if an event results in damage to their property (for example a wall is knocked down) that the ACU or Organiser will indemnify the Landowner. The policy covers this type of incident subject to a £250 excess.

SpONSORS

The policy extends to include indemnity to sponsors, should they get involved in a claim where they have become subject to litigation only due to the fact they were an event sponsor. If the sponsor has been negligent in their actions and caused injury to a third party or damage to any third party property then the ACU would pass the claim to the sponsor and their insurers.

CONTRACTUAL LIABILITY

Contractual liability is the term used in insurance to indicate an obligation imposed in a contract which goes beyond the position that would exist otherwise under the law.

Insurers customarily exclude such obligations because they do not wish to be bound by prior commitments made by their policyholders unless they have been given notice of the commitment and agreed to it.

It is not uncommon for Landowners making their land available for an event to make it a condition that damage will be made good. Thus the liability of the Organiser to the Landowner may not arise from common law because the Organiser has been negligent, or failed to exercise proper care, but purely as the result of the contract between the Landowner and the Organiser.

The ACU policy is extended within its normal limits to cover this situation, however for this to apply details of any correspondence, contract or agreement between the Organiser and the Landowner shall be advised to the ACU at the earliest opportunity and by the very latest the date at which the permit is applied for in order to check if the obligations go beyond policy limits.

WHAT IS NOT COVERED

It is important to understand what is not covered by the policy. The main points are:

Competitor to Competitor Liability – Claims by one Competitor against another Competitor are not insured whilst competing in the permitted event. Competitor means rider, passenger, entrant or sponsor.

Liability arising out of the use of Motor Vehicles loaned or hired to Competitor.

Damage or loss of property – Either belonging to the Organiser, hired or held in the

custody or control of the Organisation running the event. Note this exclusion also applies to motorcycles held in a Parc Ferme.

Borrowed/Hired Motor Vehicles or Borrowed/Hire of Equipment – It is possible that an Organiser may borrow/hire a vehicle (such as a tractor or JCB) or borrow/hire of equipment (such as fencing, or crowd barriers) to assist with the task of setting up or dismantling a course. The Organiser must ensure that the proposed use of the borrowed or hired vehicle is covered either by the owner’s existing Insurer or by making alternative arrangements separately. Loss of or damage to property in the custody or control of the Organisers is excluded.

It is a condition of the policies that ACU Codes, Regulations and Supplementary Regulations are observed and complied with. Failure to comply could prejudice the operation of the cover.

Unusual Activities – If these involve any high hazard aspects such as freestyle jumping competition, firework displays or sports such as ballooning or bungee jumping, they should be referred to Lockton for approval.

Aviation – The policies do not provide cover in respect of ownership, possession or use of aircraft. If any ancillary attraction involves aircraft, details should be submitted to Lockton well in advance of the event.

Excess – The first £250 of each and every property damage claim.

public LIABILITY – ACTION pRIOR TO THE EVENT AND IN THE EVENT OF ACCIDENT

1. Prior to the event; so that Clubs may be certain that cover is operative for any event they undertake the following steps should be taken:
 - 1.1 Apply to the ACU for an appropriate permit or exemption certificate.
 - 1.2 Officials should be briefed prior to the event on risk assessment and procedure in the event of an accident.
 - 1.3 Consider if specific advice is needed from Lockton about the event e.g. – increased indemnity limit above £40 million.
 - Attractions other than normal competition e.g. flight displays, ballooning, bungee jumping, free style displays, bouncy castles.

- Contractual liabilities incurred to property owners or landlords.
 - Use of vehicles on public roads i.e. RTA cover.
 - Aviation activity on site.
- If there are any special exposures that fall outside normal competition as shown in this handbook and therefore are not covered by the standard ACU liability insurance, full details of the event should be made available to Lockton in good time for them to be able to respond on the implications for cover and cost.
2. In The Case of a Serious Accident or Incident involving a Competitor, Official, Spectator or Property contact:
Road Race Events: Dr Paul King (07767 635420) Rowena Perks (07805 898584)
Off Road Events: Gary Thompson MBE BEM (07976 548375)
A serious incident, whilst not a full list, would include:
- Death of a rider, official or spectator
 - A spectator is hit by a bike or other vehicle
 - A rider, official or spectator is airlifted to hospital from the event
 - Any spinal injury
 - A serious head injury
 - Any other catastrophic injury
- 21 Efforts must be made immediately to collect the names and address of witnesses, which together with an account of the accident by the Marshals/Observers and the provision of any photographs taken should be passed to the Clerk of the Course who will make the information available to the ACU Steward or send the information direct to ACU Head Office as soon as possible. All information regarding a Serious Incident should be sent to ACU Head Office within three days of the incident taking place.
- 22 A full report must also be provided within three days to Lockton (24 hours in the case of a fatality). Contact details are as follows: Alex Braddish (07827 985033) email: Alex.Braddish@uk.lockton.com
Christine Hare email: christine.hare@uk.lockton.com
David Hamer (07825 781759) email: david.hamer@uk.lockton.com
- 23 Organisers should retain a full record of the event i.e. copy programme, Supplementary Regulations, final instructions, passes, scrutineer's report and list of senior officials for a minimum period of four years, or until each competitor in the event has reached 21 years of age, whichever is the longer period.
- 24 A return must be made to Lockton of the details of injured parties, on the Incident/ Accident report form provided, with brief details of the injury to each. If a fatal or serious accident occurs the original entry form must be retained for a period of four years to comply with the law. Any fatal or potentially fatal accident must be notified to Lockton and to ACU House, preferably by telephone or email, within 24 hours.
- 25 Public Liability personal injury claims valued up to £25,000 damages arising from accidents from 31st July 2013 onwards will be notified by claimant's solicitors via the Insurer electronic portal via a Claims Notification Form (CNF) which may be copied to the ACU and if so receipt should be acknowledged by the ACU to the claimant's solicitor within 24 hours of receipt. Insurers will also formally acknowledge these claims and will then look to promptly gather documents and undertake an investigation with the ACU to determine legal liability. Where it is agreed that a claim is one for a full admission of liability, Insurers will look to conclude liability enquiries within 40 working days for Public Liability claims to ensure such claims remain within the portal to benefit from the reduced fixed recoverable costs payable to the claimant's solicitors. Every cooperation should be given to Insurers and their investigators during the investigation period to ensure the MOJ portal timelines are complied with. Claims that are denied (in part or in full) will exit the portal process and where it has been agreed following investigations that a claim is one to deny in part or in full, the Insurer has up to 90 calendar days to communicate their decision to the claimant's solicitors as per existing Civil Procedure Rules.
- 26 Organisers, competitors or officials who are involved in an accident will be defended by Solicitors chosen by ACU's insurers.

- The costs of a club, competitor or official appointing their own Solicitor are not covered under the Master Policy.
- 27 Claim forms will be sent direct to competitors who request them from Lockton.

MEDICAL MALPRACTICE INSURANCE

The Master policy is automatically extended to provide medical malpractice cover for volunteer paramedics registered with the (HPC) Health Professions Council. Cover also applies to qualified nurses registered with the (RCN) Royal College of Nursing, medical assistants and event officials at ACU permitted events. The limit of indemnity is £10m in the aggregate for each period of 12 months. Cover is subject to an excess of £250 each and every claim.

INSURANCE POLICY SUMMARY – KEY FACTS FOR COMPETITORS (PREMIER PERMITTED EVENTS ONLY)

This policy summary provides important

information about the Public Liability and Personal Accident Insurance. This applies each time you are eligible to compete in any ACU permitted event or event for which a certificate of exemption has been issued or run in accordance with the International Sporting Code of the FIM. These are not the full terms and conditions. The full terms and conditions can be found in the insurance policy a copy of which can be viewed on application to the ACU’s Company Secretary at ACU House, Wood Street, Rugby. The insurance is governed by English Law.

Making a Claim: To make a claim please contact Lockton Alex Braddish on 0121 232 4597. In the case of an out of hours emergency please see above for the contact details for major incidents.

Complaints: If you are not satisfied with the service you receive from us you should contact in the first instance David Hamer Lockton Companies LLP, St Botolph Building, 138 Houndsditch, London EC3A 7AG Mobile 07825 781759 email: david.hamer@uk.lockton.com.

Features and Benefits	Significant exclusions and limitations
<p>Public Liability You are covered for legal liability you may incur for injury caused to third parties and damage to their property.</p>	<p>Injury caused to any other Competitor during a race. Road Traffic Act liability unless specifically provided for the event. The organising club will be responsible for the first £250 of each claim in respect of third party property damage</p>
<p>Limit of indemnity Premier cover £40,000,000 each and every claim Basic cover £10,000,000 each and every claim</p>	
<p>Personal Accident (Premier Cover only) Death £10,000 (£7,500 for 6–15 year olds) Permanent total disablement £20,000 Quadriplegia £40,000 Hospital Benefit £2,000 Loss of Limb(s) £20,000 Loss of Sight of eye(s) £20,000</p>	<p>Personal accident cover for competitors does not apply to events run with only Basic insurance. Temporary total disablement, illness of any kind. Suicide or attempted suicide. Your own criminal act. Being under the influence of alcohol or drugs. Terrorism. Hospital Benefit becomes payable after 14 days hospitalisation as a result of an accident, which must occur within 12 months of the date of accident.</p>
<p>Operative Time Cover for both sections only applies whilst you are signed on at events held under permit or certificate of exemption including setting up and dismantling at the event.</p>	<p>Territorial Limits Cover is only provided for events taking place under a Permit within Great Britain, Isle of Man and the Channel Islands.</p>

If we are unable to satisfactorily resolve your problem you may be eligible for the Financial Ombudsman Service.

PERSONAL ACCIDENT TO RIDERS AND PASSENGERS WHO ARE MEMBERS OF THE ACU

(A) Below International Motorcycle Union of Ireland (MCUI) Permitted Events

The ACU's Personal Accident to Riders and Passengers Master Policy may be extended in respect of authorised participation. All Competitors should contact the ACU prior to entry/departure to obtain their Start Permission.

Note: Competitors without appropriate insurance or authorisation may not be allowed to compete.

(B) Minors

IT IS MOST IMPORTANT that any injury to a minor (under 18 years of age) reported on an accident report form should clearly indicate the age of the injured person.

(C) Events with Foreign Competitors

It should be noted that only ACU registered members or licence holders are covered by the ACU's Premier Personal Accident Policy. No cover applies to events run under Basic insurance. Holders of licences issued by other FMNs are required to make their own arrangements.

Please note that the scale of benefits is that specified by the ACU to apply to ACU licence holders competing in Events within ACU territory. (Article 110.2 of the FIM Sporting Code).

ROAD TRAFFIC ACT LIABILITY

Third Party Road Risks cover has been arranged to cover any Competitor, Marshal or Official signed on for a Permitted Event arising from the use of any motor vehicle in connection with the event in areas of the event where the Road Traffic Act is deemed to be applicable.

The insurance is event specific and will override any other cover that may be in place. However, it is still recommended that all persons using their vehicle at an event make their own insurance providers aware of this use of the vehicle to ensure there are no gaps in cover provided.

PERSONAL ACCIDENT INSURANCE FOR OFFICIALS

The ACU has effected a Personal Accident Insurance policies (Premier and Basic) all of which provide benefits on the scale below to officials acting at ACU permitted meetings who suffer injury. The cover applies to associated activities necessary to an event such as, setting up and dismantling a course and travelling to and from the event. The ACU will consider sympathetically the provision of counselling where appropriate.

TABLE OF BENEFITS

The benefits under the Personal Accident policies are either payable for death, loss of Limb(s) and/or Eye(s) OR Permanent Total Disablement OR Temporary Total Disablement (this applies to Officials only). Officials who are unemployed receive weekly benefit only whilst hospitalised or housebound. Compensation is payable in accordance with the following table of benefits in respect of an accident resulting in

1. Death.
2. Loss of or loss of use of two limbs or the sight of two eyes or the loss of use of one limb and one eye, the loss of or loss of use of a limb or the sight of an eye.
3. Permanent Total Disablement.
4. Temporary Total Disablement.
5. Fracture.
6. Dislocation.
7. Physiotherapy.
8. Hospitalisation.

Note: Repatriation costs are not covered.

INSURANCE FOR EVENTS HELD OUTSIDE GREAT BRITAIN

For all FIM Inscribed events and FIME championship events, competitors will be provided their Start Permission and Insurance from the FIM. For all other events held abroad (including Ireland) where the event is held under an FMN permit/authorisation, competitors must apply for a Start Permission and Insurance from ACU Head Office.

CHECKLIST OF ESSENTIAL DOCUMENTS TO TAKE WITH YOU WHEN COMPETING ABROAD

- ACU/FIME/FIM Competition licence of

Benefit	1	2	3	4	5	6	7	8
Officials age over 16	£65,000	£65,000	£65,000	up to £200 per week (Max. 104 weeks)	£2,500	£1,000	£500	£2,000 following hospitalisation of 2 weeks or more, within 12 months of the date of accident
Officials age 14 to 16 In full time education	£7,500	£20,000	£20,000	£75 per week for home tuition	£2,500	£1,000	£500	£2,000 following hospitalisation of 2 weeks or more within 12 months of the date of accident

appropriate grade. (See ACU Competition Licence Application Form).

- Necessary competition insurance – according to the ACU/FIM scales.
- A current European Health Insurance Card for each member of the team in order to receive reciprocal health benefits in most countries.

We strongly recommend that full travel insurance is arranged for your trip, in addition to FIM Insurance cover which only provides protection during the event itself.

OTHER RECOMMENDED DOCUMENTATION

- Passport with Visa if appropriate.
- Driver’s licence.
- International Driving Permit (IDP) – where necessary (from AA or RAC).
- Bail Bond – where necessary (from AA or RAC).
- Vehicle insurance documentation for all vehicles. Check with your insurance broker, as requirements vary from company to company.
- Vehicle registration documents – V5 or VE103 or letter of authority if you do not own the vehicle.
- Travel Insurance – including medical and repatriation cover where not otherwise arranged.
- Competitors, who travel with assistants, or as part of a team, should not overlook their needs including travel insurance.
- International identification plate (GB) for vehicles.

FOREIGN RIDERS

Foreign riders are Competitors affiliated to

MCUI do not have their FMN within 12 months of the date of accident an ACU Trials Registration. Where a Foreign rider takes part in an ACU permitted event the following guidelines apply:

1. Road Race, Drag, Sprint, Hill Climb, Supermoto, Motocross, Trials, Enduro and Grass Track: Competitors with a valid competition licence and a “Start Permission” from their home FMN or evidence of FIM insurance cover pay the per capita rate per day for liability. Note: Competitors’ PA benefits and Repatriation expenses are not covered.
2. Road Race, Drag, Sprint and Hill Climb, Supermoto, Motocross, Trials, Enduro and Grass Track: Competitors without a valid competition licence issued from their home FMN and evidence of FIM level insurance cover are not allowed to compete.
3. Other events: Competitors in possession of a “Start Permission” from their home FMN or evidence of approved FIM insurance cover, pay the per capita rate per day for Public Liability.

ACTIONS TO BE TAKEN BY SENIOR OFFICIALS FOLLOWING AN INCIDENT INVOLVING SERIOUS INJURY TO A COMPETITOR, OFFICIAL OR A SPECTATOR

A full investigation is required in the event of the following:

Fatalities, loss of sight or limb/s, paralysis, serious head injuries, potential fatality any spinal injury, a spectator being hit by a bike or other vehicle and any incident where a rider, official or spectator is airlifted from the event. (It is the responsibility of the Steward/Clerk of the Course to use experience/ common sense and to also telephone one of the numbers below)

Telephone:

- In the event of a major incident telephone
- 1) Road Racing – Dr Paul King (07767 635420), Rowena Perks (07805 898584)
 - 2) Off Road Events – Gary Thompson MBE BEM (07976 548375)
 - 3) Advise ACU as soon as possible

Immediate information gathering for insurer by the Steward/Clerk of the Course/ Organiser/Venue Operator

- Photograph Scene
- Impound vehicles
- Obtain witnesses' names, addresses and telephone numbers
- Seek and obtain video and photographic evidence from any source. Be cautious if asking spectators

Information to be forwarded to Governing Body/Insurer

- Steward's Report
- Marshal/Observer Reports
- Any other witnesses' reports
- Medical Log/Report
- Scrutineer's Report
- Racing/Radio Log
- Signing on sheet
- Risk Assessment

Forward to Insurer:

- Documents provided by Steward/Organiser as listed
- Event Regulations
- Event Final and Supplementary Instructions
- Event Programme
 - Track Plan
- Copy of Permit

MEDICAL SERVICES – TERMINOLOGY

Medical Officer (MO) Doctor: A medical practitioner (Doctor), who holds:

- full registration and a licence to practice from the General Medical Council (GMC)
- medical malpractice cover appropriate for pre-hospital immediate care (NHS Crown Indemnity is not applicable).
- if subject to GMC Approved Practice Setting regulations (APS, ie before first revalidation), must have agreement from their Education Supervisor

Paramedic (PM) State Registered Paramedic who holds:

- registration from the Health Professions Council (HPC)
- medical malpractice cover (NHS Crown indemnity is not applicable)

If a Paramedic or Junior Doctor with full GMC registration is present at an event as an individual volunteer (being paid expenses) and

not present in a commercial capacity, then they are indemnified for Medical Malpractice under the ACU’s insurance policy. This concession does not apply to GPs or Consultants.

First Aid Personnel A person holding a current certificate of First Aid competency.

Ambulance An ambulance, by law, must be registered with the DVLA (Driver and Vehicle licensing Authority) and be CQC-registered in order to transport a casualty to hospital. An

ambulance must have an appropriately qualified driver to transport a casualty under blue lights. It must comply with the FIM the minimum equipment regulations for a type C vehicle; that is:

- **Medical:** A stretcher (preferably standardised), oxygen supply, apparatus to immobilise limbs and vertebral column. First aid medicaments and materials.
- **Technical:** Radio communication. Visible and audible signals.
- **Staffing:** An Ambulance must be staffed by 2 First Aid Personnel who can be the two minimum First Aid Personnel required at an event.

An Ambulance may act as a Medical Centre **but** if so it must be a vehicle additional to the minimum Ambulance requirement.

GENERAL

For each motorcycle sporting discipline, the individual ‘minimum medical requirements’ are listed in the Handbook within their own sections under the heading ‘Medical Services’. This is because, understandably, the minimum medical requirements vary between the types of motorcycle sport.

The points listed below, where relevant to a discipline, will apply to ALL competitive motorcycle sports and the wording will be the same for all:

1. If only one Ambulance is listed as the minimum requirement at an event Organisers are reminded that if it has to leave the event all practising and racing must stop until its return or replacement. It is incumbent therefore on Organisers of events to remember their commitment and duty of care to competitors in ensuring that sufficient medical services for the type of event, dictated by a risk assessment of the expected number of injuries, are in place prior to the start of practising and racing and remain in place until the event has completely finished.
2. When medical cover is required at an event, the Doctors and Paramedics should have available resuscitation drugs conforming to Resuscitation Council Guidelines and a supply of parenteral and oral analgesics. Organisers should ensure that such systems, equipment and supplies are available at the venue by discussion with their medical provider. Any further drugs and equipment that may be deemed to be appropriate by way of specialist expertise are the responsibility of the individual Doctor or Paramedic.
3. Auxiliary vehicles, such as 4x4 with a stretcher, cannot replace an Ambulance but such vehicles might, at certain event sites, be used in addition to and as the final form of transportation to the Ambulance for the event.
4. If there is a requirement for first aid personnel to be present then they can be the two crew members of an Ambulance, assuming that one is present as a minimum requirement, but they must be available for all the practices and races. Such first aid

personnel are an additional requirement to any Doctors or Paramedics required to be present at the meeting.

5. If there is a requirement for full first aid equipment, including a stretcher, then this can be the same equipment as that defined in the minimum equipment requirements for an Ambulance.
6. If the minimal medical cover required is for only one Doctor or only one Paramedic to be present then, if the only one available has to leave, for whatever reason, the practices or races must stop until their return or replacement.
7. If a Doctor is required at an event then they must be on site. It is not sufficient to have the name and address of a distant Doctor, who would or might be available if required.
8. The nearest Trauma Centre and/or Trauma Unit should be identified and notified in writing of the time, date and place for the meeting.
9. If a Doctor is involved in the treatment of competitors or spectators at an event, they should not normally be involved with drug or alcohol testing of competitors.
10. If a medical centre is available at a circuit or the site of an event then it should be fully operational and staffed appropriately. If deemed acceptable, an Ambulance or similar unit may act as a medical centre but if so, it must be additional to the minimum Ambulance requirements.
11. If no MO or PM is required at an event then at least one of the two Ambulance crew must be qualified as an IHCD Emergency Technician (EMT) or the Voluntary Aid Society (VAS) equivalent, rather than just a first aid person.
12. If a competitor is involved in an incident involving potential injury, but is not, at the time, taken to Hospital for further treatment, then a relative, or a member of their crew, should be given a copy of the medical assessment or Ambulance report form completed by the event medical personnel following the incident.

A list of Medical Services Providers can be found under the Documents tab in the Clubs and Centres login by visiting <https://secure.acu.org.uk>

Requirements for safety precautions at all events held under an ACU permit

It should be generally realised that the organisers of speed events have a legal responsibility to the general public and therefore it is the duty of these organisers to ensure that all reasonable precautions are taken to protect the public.

Whilst organising clubs are insured under the Promoters Third Party Policy in respect of their legal liability, it is a condition of the policy that the promoters of an event must comply strictly with the National Sporting Code and any additional requirements as may be specified by the Permanent Course Licence or Temporary Course Certificate.

Clubs failing to do so stand in grave danger of any claims being repudiated to the club by the insurers under the terms of the policy covering legal liability.

The safety precautions to be adopted are provided with the Permanent Course Licence or Temporary Course Certificate for the particular course but the following general requirements must be observed.

The attention of organisers is drawn to the provision of the NSC which stipulates that no alteration of the requirements contained in the Permanent Course Licence or Temporary Course Certificate shall be made without the prior approval, in writing, of the ACU.

It is recognised that circumstances may arise in which it is necessary to make certain alterations to the course on the day of the meeting but any such alterations must be approved by the Stewards of the Meeting and details given in their report to the authority granting the permit.

WARNING & pROHIBITION NOTICES

The following requirements regarding the display of notices are applicable to all speed events.

WARNING NOTICE (A) (29 × 20 INCHES.)

Warning notices as detailed opposite must be displayed on each side of every entrance to the course, including the entrance to car parks and paddock.

These notices, mounted on stakes, must be prominently displayed and with the top of the notice at least 4ft. from the ground and where they can be easily read by the public before any admission charge is paid, or where no admission charge is made before entry is gained into the circuit.

Where it is not possible to define the limits of the site and to control admission of the public (e.g. War Department and heath land) warning notices must be profusely displayed around the course and also in the car parks. These notices must be mounted on stakes, and the top of the notices must be at least 4ft. from the ground.

**NOTICE
WARNING TO THE
PUBLIC MOTOR SPORT
CAN BE
DANGEROUS**

Despite the organisers taking all reasonable precautions, unavoidable accidents can happen. Please comply with all instructions of marshals and notices and remain in permitted areas only.

THEY ARE CONCERNED WITH

WARNING NOTICE (A2) (29 × 17 INCHES.)

Warning notices as detailed opposite must be displayed on each side of every entrance to the course, including the entrance to car parks and paddock.

These notices, mounted on stakes, must be prominently displayed and with the top of the notice at least 4ft. from the ground and where they can be easily read by the public before any admission charge is paid, or where no admission charge is made before entry is gained into the circuit.

Where it is not possible to define the limits of the site and to control admission of the public (e.g. War Department and health land) warning notices must be profusely displayed around the course and also in the car parks. These notices must be mounted on stakes, and the top of the notices must be at least 4ft. from the ground.

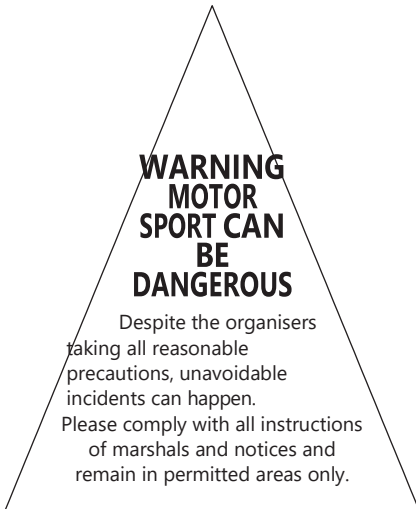

PROHIBITED AREA NOTICE (B) (29 × 20 INCHES.)

Areas where the public are not permitted must be clearly defined by the display of an adequate number of "Prohibited Area" notices mounted on stakes. These notices must also be displayed in the prohibited area between the "double roping" and facing the public. Warning Notice

(A) should also be erected in these areas but they must be used in addition and not in place of Prohibited Area Notice (B). Notices should be displayed within the prohibited area, facing the public and mounted on stakes or fixed to the inner fencing.



WARNING NOTICE (C) (20 × 15 INCHES.)

Those parts of the course to which the public may be admitted and where it is neither practical nor necessary to erect a rope barrier, e.g. those parts of the course which are straight and are only used by the public to reach other parts of the course, may be indicated by the erection of the special type of Warning Notice (C). These notices mounted on stakes with the top of the notices at least 4ft above ground level should be displayed at least 30ft from the course. It is recommended that the limit of these areas should also be defined by a boundary tape affixed to the stakes supporting the notices.



DECLARATION – ADMISSION TICKETS, PASSES, ARMLETS, ETC.

Subject to the provision of the Sunday Observance Act 1780, no person may be allowed to any part of the circuit without a suitable pass or ticket. All tickets and passes must bear the following wording shown below in full and if the wording appears on the reverse side then the words "For Conditions of Admission See Over" must be clearly printed on the face thereof.

Where a ticket is cancelled by being torn in half, the full wording and, where applicable, the "For conditions of admission see over" must appear on each half.

Where a charge is made for admission into special or "reserved" enclosures a ticket bearing the approved declaration must be issued in exchange for payment to enter these enclosures.

All vehicle passes must bear the same wording and comply with the above requirements.

WARNING
MOTOR SPORT CAN
BE
DANGEROUS

Despite the organisers taking all reasonable precautions, unavoidable accidents can happen. Please comply with all instructions of marshals and notices and remain in permitted areas only.

OFFICIAL PROGRAMME

The declaration as outlined above should be printed in full on the outside front cover of all Official Programmes. Where this is not possible it must be printed in full in the programme and the words "For conditions of admission see inside" printed on the outside cover.

SIGNING ON

All riders, passengers, officials and assistants, press and team crew must sign a declaration on the relevant signing on form (available from the ACU).

AGE LIMITS FOR OFFICIALS & ASSISTANTS

All event Executive and Administrative Officials shall be 18 years of age or over.

Marshals: All Assistant Officials whose function is to be carried out at the immediate track-side must be at least 16 years of age with the exception of marshals who are in membership of a recognised corps of cadets/scouts/other discipline groups who must be at least 14 years of age.

Trials Observers: Trials Observers must be at least 12 years of age.

Parental Agreement and responsible Persons: All Assistant Officials who are under 18 years of age must have obtained parental agreement to carry out the duty and the signing- on signature must be countersigned by someone who is responsible for the official at the event. **General:** When using the services of minors (persons under 18 years of age) for any official duties at any event special attention must be given to any risks which may be associated with the duty, and to the previous experience of the official.

MANDATORY SIGNING FOR PUBLIC SAFETY AT MOTORCYCLE ENDUROS

This signing should be the responsibility of the Safety Officer. It should be erected and removed as a separate task from the route marking itself.

The aims are to advise other users of the countryside that the event is taking place, to reduce the prospect of conflicts and complaints, to add to the event's safety precautions.

Unless spectators are to be catered for, the signs should not 'advertise' the event. However each should be carefully positioned to be clearly visible to those members of the public (or competitors and marshals) for whom its message is intended. The notional plan opposite shows where the signs should be located but every venue requires the exercise of local knowledge and experience.

Note: use of signs F or G does not enable a footpath, bridleway or byway to be incorporated in a timed special stage.

These signs may be obtained from: Mr V. Madeley, Greenfields, Ceri, Newtown, Powys SY16 4LH. Tel: 01686 670596

A **NOTICE**
WARNING TO THE
PUBLIC MOTOR SPORT
CAN BE DANGEROUS

Despite the organisers taking all reasonable precautions, unavoidable accidents can happen. Please comply with all instructions of marshals and notices and remain in permitted areas only.

THEY ARE CONCERNED
WITH YOUR SAFETY

B **CAUTION**

This right of way and other parts of the forest will be in use during the weekend for an authorised MOTORCYCLE COMPETITION
 Tel: ACU 01788 566400

C **WARNING**

You are approaching a Motorcycle Enduro. You are present in vicinity of the course by your own choice & should exercise the utmost caution
 Tel: ACU 01788

D **CAUTION**

Motorcycle Competition in progress
 Tel: ACU 01788 566400

E **THANK YOU**

Tel: ACU 01788 566400

F **CARE**



Tel: ACU 01788

G **CARE**



Tel: ACU 01788

H **!**

ROAD AHEAD

Sign	Colour	Size	Description
A	Black on White	29" x 20"	ACU Warning Notice (A)
B	Black on White	A4	'Caution – This right of way etc'
C	Black on White	A4	'Caution – This part of the forest etc'
D3	Black on Yellow	A3	'Caution – Motorcycle Competition in Progress'
D4	Black on Yellow	A4	'Caution – Motorcycle Competition in Progress'
E	Black on Yellow	A4	'Thank You'
F	Black on Yellow	A4	'Footprint'
G	Black on Yellow	A4	'Footprint and Horseshoe'
H	Red/Black on White	A3	'! Road Ahead'

National plan of signing for public safety at motorcycle Enduros

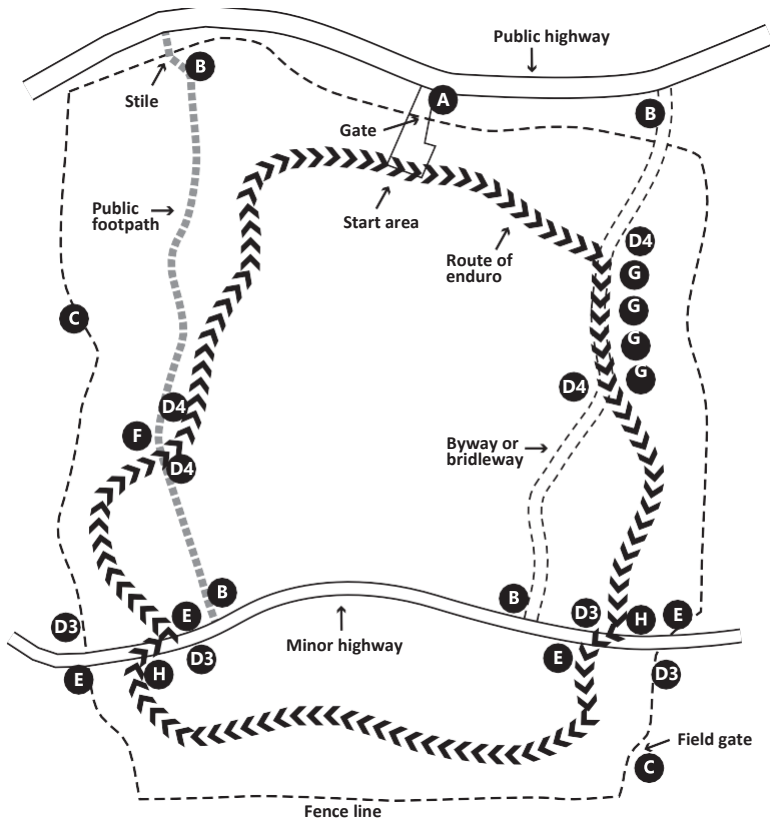

This signing should be the responsibility of the Safety Officer. The aims are to

- advise other users of the countryside that the event is taking place.
- reduce the prospect of conflicts and complaints.
- add to the event's safety precautions.

Unless spectators are to be catered for, the signs should not advertise the event.

Each should be carefully positioned to be clearly visible to those members of the public or competitors or marshals, for whom its message is intended.

Every venue requires the exercise of local knowledge and experience.

Signs should be erected and removed as a separate task from the route marking itself.

Note: Use of signs F and G does not enable a footpath, bridleway or byway to be incorporated in a timed special stage.

TRAVELLING MARSHALS

These are a vital part of the safety and smooth running of Enduros and their importance should not be underestimated however they have a responsibility to the Organisers and Riders and as such this should be outlined to any Travelling Marshals before they commence with their duties.

Areas to be highlighted to Travelling Marshals should be:

- Do not ride against the direction of the course whilst off road
- Be prepared to act if you come across an injured rider – contact medical staff/ Organisers, ensure the rider is safe from other riders (place bike as a barrier/divert route).
- Make sure any riders with broken down machines are safe and shown/taken out of the forestry.
- Repair/replace any route marking tape as required.
- Ensure any gates you are charged with are closed after the event.

Organisers should ensure Travelling Marshals:

- are signed on
- are adequately briefed
- have contact details of the Organisers for emergencies
- advise the Organisers when they have finished their duties
- are wearing suitable protective clothing including helmets on motorcycles and quads.

section
STANDING
REGULATIONS

Motocross

Standing Regulations

SECTION 1

MEETINGS

Definitions	106
Categories of Meetings	106
International	106
European Open	106
National	106
Open	107
Restricted	107
Supercross	107
Beachcross	107
Minibike	107
Eligibility of Foreign Riders in National, Open and Restricted Meetings	107
Practice Meetings and Test Days	107
Conditions for Motocross Meetings	107

SECTION 2 ELIGIBILITY

2.1 Licences	108
2.2 Capacity and Licence Restrictions	109
2.3 Youth	110
2.4 Adult	111
2.5 Physical Eligibility/Proficiency Assessment	111

SECTION 3 CLASS VARIATIONS

3.1 E4 Class	111
3.2 Automatic Class	111
3.3 65cc Junior Class	112
3.4 85cc Small Wheel and 85cc Big Wheel Classes	112
3.5 Youth 125cc	112
3.6 125/250F	112
3.7 MX2	112
3.8 MX1	112
3.9 Open (Adult)	112
3.10 Formula Classes	112
3.11 50cc/100cc Quad Class	112
3.12 150cc/250cc Quad Class	112

SECTION 4 LICENCES AND REGISTRATIONS (OFFICIALS)

4.1 Licensed Officials	113
4.1.1 Clerk of the Course/Race Director	113
4.1.2 Steward/Referee	113
4.1.3 Chief Technical Officer	113
4.1.4 Measurer	114
4.1.5 Timekeepers	114
4.2 Unlicensed Officials	114
4.2.1 Incident Officer	114
4.2.2 Secretary of the Meeting	114
4.2.3 Club Stewards	114
4.2.4 Marshal	114
4.2.5 Medical Officer	115

SECTION 5 SPECIFICATION OF MOTORCYCLE

5.1	Brakes	115
5.2	Tyres	115
5.3	Mudguards	115
5.4	Clutch and Brake Levers	115
5.5	Footrests and Handlebars	115
5.6	Lamps	115
5.7	Throttle	115
5.8	Exhaust Pipes	116
5.9	Running of Engines	116
5.10	Fuel	116
5.11	Ignition Cut-Out	116
5.12	Chain Guards	116
5.13	Construction	116
5.14	Wheels	116
5.15	Engines	117
5.16	Electric Motorcycles	117
5.17	Miscellaneous	119

SECTION 6 NUMBER PLATES

6.10	Number Plate Diagram	120
------	----------------------	-----

SECTION 7 TECHNICAL CONTROL**SECTION 8 SAFETY**

8.1	Medical Services	122
8.2	Clothing	124
8.2.1	Motocross, Supercross and Beachcross	124
8.2.2	Minibike	124
8.3	Track Safety	124
8.4	Fire Extinguishers	124
8.5	Riding in the Paddock	125
8.6	Track Access	125
8.7	Flag Signals	125

SECTION 9 RACE MANAGEMENT

9.1	Entries	125
9.2	Practice	126
9.3	Start Positions	126
9.4	Electronic Timekeeping	126
9.5	Races	126
9.6	Method of Starting	126
9.7	Starter's Orders	126
9.8	False Starts	127
9.9	Stopping a Race	127
9.10	Finish of Race	127
9.11	Race Results	128
9.12	Change of Machine	128
9.13	Change of Sidecar Passenger	128
9.14	Outside Assistance	128
9.15	Foul, Unfair or Dangerous Riding	128

9.16	Course Conduct	129
9.17	Awards	129

SECTION 10 GENERAL

10.1	Instructions to Riders	129
10.2	Conduct	129
10.3	Parental Responsibility	129
10.4	Declaration	129
10.5	Compliance with Regulations	129
10.6	Dogs at Off Road Motorcycle Events	129

SECTION 11 BEACHCROSS

11.1	Specification of Motorcycle	130
11.2	LPG Fuel/Diesel	130
11.3	Circuit	130
11.4	Starter's Orders	130
11.5	Finish of a Race	130
11.6	Duration of a Race	130
11.7	Interruption of a Race	130
11.8	Disqualifications	130

SECTION 12 CROSS COUNTRY QUADS STANDING REGULATIONS

12.1	Meetings	130
12.2	Eligibility	131
12.3	Class Variations	132
12.4	Licences and Registrations (Officials)	132
12.5	Specification of a Motorcycle	132
12.6	Number Plates	132
12.7	Technical Control	132
12.8	Safety	133
12.9	Race Management	133
12.10	General	135

SECTION 13 GRADING

13.1	ACU Motocross Riders Expert Grading Scheme (Adult)	135
------	--	-----

SECTION 14 MOTOCROSS MOTORCYCLE	136
--	------------

The National Sporting Code of the ACU and the Standing Regulations together with the Supplementary Regulations and any Final Instructions shall apply to all Motocross Events held under an ACU Permit.

SECTION 1 MEETINGS

1.1 DEFINITIONS

- **FIM** – Fédération Internationale de Motorcyclisme – The international governing body of motorcycle sport
- **FIME** – Fédération Internationale de Motorcyclisme Europe – European governing body for motorcycle sport
- **FMN** – Federation Motorcycliste Nationale – FIM affiliated National federations
- **ACU** – Auto Cycle Union – The FMN of the FIM for the British Isles excluding Northern Ireland
- **SACU** – Scottish Auto Cycle Union
- **MCUI** – Motor Cycle Union of Ireland – The FMN of the FIM for Ireland
- **IMN** – International Meeting Number issued by the FIM

1.2 CATEGORIES OF MEETINGS

- Restricted Meetings
- Open Meetings
- National Meetings
- European Open Meetings
- International Meetings

1.2.1 INTERNATIONAL

1. The Permit shall be issued by ACU Headquarters for a meeting inscribed on the International Calendar of the FIM and having an FIM International Meeting Number (IMN).
2. An International meeting is open to Entrants and Riders of more than one nation who must hold an International Licence or a National licence issued by the ACU, the SACU or their FMN valid for the particular meeting concerned.
3. All riders not holding a licence issued by the ACU or SACU must carry proof of Insurance and a written Start Permission document issued by their FMN.

Note: This includes all riders holding a licence issued by the MCUI.

1.2.2 EUROPEAN OPEN

1. The permit shall be issued by ACU Headquarters for a meeting inscribed on the Calendar of the Fédération Internationale de Motorcyclisme Europe (FIME) and having a European Meeting Number (EMN).
2. A European Open meeting is open to Entrants and Riders of more than one European nation who must hold the appropriate Competition Licence valid for the particular meeting concerned.
3. All riders not holding a Licence issued by the ACU or SACU must carry proof of Insurance and a written Start Permission document issued by their FMN.

Note: This includes all riders holding a licence issued by the MCUI.

1.2.3 NATIONAL

1. The Permit shall be issued by ACU Headquarters.
2. A National meeting is open to Entrants and Riders who are the holders of an ACU Motocross or International Motocross Licence issued by the ACU, SACU or any FMN valid for the particular meeting concerned.
3. All riders not holding a Licence issued by the ACU or SACU must carry proof of Insurance and a written Start Permission document issued by their FMN.

Note: This includes all riders holding a licence issued by the MCUI.

1.2.4 OpEN

1. The Permits for events run under basic insurance are issued by ACU Headquarters.
2. The Permits for events run under Premier insurance are issued by the Centre to which the club is affiliated.
3. An Open meeting is open to Entrants and Riders who are the holders of a Licence issued by the ACU, SACU or any FMN valid for the meeting concerned.
4. All riders not holding a Licence issued by the ACU or SACU must carry proof of Insurance and a written Start Permission document issued by their FMN.

Note: This includes all riders holding a licence issued by the MCUI.

1.2.5 RESTRICTED

1. The Permits for events run under basic insurance are issued by ACU Headquarters.
2. The Permits for events run under Premier insurance are issued by the Centre to which the club is affiliated.
3. A Restricted meeting is open to Entrants and Riders who are the holders of a current Licence issued by the ACU, SACU or any FMN valid for the meeting concerned.
4. The Supplementary Regulations issued for the event must specify all restrictions and requirements of eligibility.

Note: This includes all riders holding a licence issued by the MCUI.

1.3 SUPERCROSS

1. Arena/Supercross is defined as a motorcycle event conducted in a stadium type facility, open or fully closed, using Motocross motorcycles.
2. The permits for Supercross events are issued by ACU Headquarters.
3. Supercross events may be run under any of the above categories.

1.4 BEACHCROSS

1. The permits for Beachcross are issued by ACU Headquarters.
2. Beachcross events may be run under any of the above categories.

1.5 MINIBIKE

1. The permits for Minibike events are issued by ACU Headquarters.
2. Minibike events may be run under any of the above categories.

1.6 ELIGIBILITY OF FOREIGN RIDERS IN NATIONAL, OpEN AND RESTRICTED MEETINGS

1. The Supplementary Regulations issued for the event must specify the licence qualification and eligibility requirements of foreign riders.
2. All riders must have a current Licence and Start Permission from their own Federation valid for the event.

1.7 PRACTICE MEETINGS AND TEST DAYS

1. Permits for Practice Meetings and Test Days may be issued on application to ACU Headquarters. (Please request a copy of the Practice Permit Guidelines from the ACU Head Office when applying for this type of permit)
2. No such event may be held unless the appropriate Permit and Insurance has been issued.

1.8 CONDITIONS FOR MOTOCROSS MEETINGS

1. The organiser must be affiliated or approved by the ACU.
2. The venue must hold a current Track Certificate issued by the ACU.

3. The permit issuing authority must approve the Supplementary Regulations for the event and issue an ACU Permit prior to publication and circulation. Applications should be made a least six weeks prior to the meeting date.
4. The race office must remain operative with all equipment in place until the end of the period provided for the lodging of a protest or appeal, and all officials and marshals must remain at the circuit and available to the Clerk of the Course and the Stewards during that period.

SECTION 2 ELIGIBILITY

2.1 LICENCES

1. For National competitions, entrants, riders and passengers must hold a current competition licence for International or National events issued by the Auto Cycle Union, Scottish Auto Cycle Union or any FMN.
2. For all competitions of below National status, a current competition licence is required.
3. Day Licences. A One Event Competition Licence grants the same benefits of an annual licence for the duration of one event only and is available for Motocross, Supercross, Beachcross or Minibike events up to and including National status.
4. Riders in possession of a Motocross Dual (youth open/adult MX) licence may compete in either Youth or Adult motocross events. Riders must choose the class at the time of entry as it is not permitted to compete on both Youth and adults races at one meeting. (This is not applicable to Supercross).
5. Details of eligibility will be found in the Supplementary Regulations of the event.
6. Youth only: All new applications must be accompanied by a photocopy of the rider's birth certificate.

Youth Solo

Age on 1 Jan	Grade	Engine Capacity	Wheel Size/ Specification
4–7 years	E4	Electric max 1.5kw output	10 inch rear, 10 inch front
6–7 years 6–8 years	Automatic	Minimum 49cc 2 or 4 stroke. Maximum 50cc 2 or 4 stroke single speed automatic, no manual clutch	Maximum 12 inch rear, 15 inch front
7–10 years	65cc Junior	Minimum 60cc 2 stroke or 85cc 4 stroke. Maximum 65cc 2 stroke or 110cc 4 stroke	12 inch rear, 14 inch front
9–12 years	85cc Small Wheel, Intermediate	Minimum 70cc 2 stroke or 125cc 4 stroke. Manual clutch, maximum 85cc 2 stroke or 150cc 4 stroke	14 inch rear, 17 inch front
11–14 years	85cc Big Wheel, Senior	Minimum 70cc 2 stroke or 125cc 4 stroke. Manual clutch, maximum 85cc 2 stroke or 150cc 4 stroke	16 inch rear, 19 inch front
13–17 years	125cc	Minimum 120cc 2 stroke maximum 125cc 2 stroke, manual clutch	19 inch rear, 21 inch front
14–17 years	125/250f	Minimum 120cc 2 stroke or 175cc 4 stroke. Maximum 150cc 2 stroke or 250cc 4 stroke. Manual clutch.	19 inch rear, 21 inch front

Youth Solo Riders may continue in the youth 125/250f class until the end of the year in which their 18th birthday falls.

2.2 CAPACITY AND LICENCE RESTRICTIONS

Adult Solo

Age on 1 Jan	Engine Capacity
15 years	Minimum 120cc up to maximum 650cc 2 stroke Minimum 175cc up to maximum 650cc 4 stroke Electric powered machines with an output of up to 16kw (22hp) measured at the rear wheel

Sidecar

Age on 1 Jan	Grade	Specification
15 years	Driver	Over 350cc and up to 1000cc 4 stroke and up to 750cc 2 stroke
15 years	Passenger	

Adult Quad

15 years		Up to 550cc max 2 cylinders 2 stroke
15 years		Up to 800cc 4 stroke max 1 cylinder

Youth Quad

Max cc	Age	Type	Specification
50cc (Y1)	7–9 Yrs	Automatic Quad	Performance Modifications are allowed up to a maximum of 50cc. Engine must not exceed 50cc at time of Manufacture.
100cc Auto (Y2)	8–13 Yrs	Auto, 100cc Production Quads built by the manufacturer	Engine must not have exceeded 100cc 2 Stroke Auto/150cc 4 Stroke Auto
100cc Open (Y2)	9–13 yrs	Open Geared Class Max 100cc 2 Stroke/150cc 4 Stroke	Engine must not have exceeded 119cc 2 Stroke/179cc 4 Stroke.
150cc Open 2–150 (Y3)	11–16 Yrs	Open Geared Class Max 100cc 2 Stroke Air Cooled/150cc 4 Stroke Water Cooled	Engine must not exceed 119cc 2 Stroke/179cc 4 Stroke. 150cc Open 2 Class compete in the 250cc Race Group
250cc Air Cooled (Y3)	11–16 Yrs	Air Cooled Production Quads	Performance Modifications are allowed to the Engine & chassis up to a maximum of 239cc 2 Stroke/299cc 4 Stroke. Frame & Engine must be by the original Manufacturer. Engine must not exceed 239cc 2 stroke/299cc 4 Stroke
250cc Open (Y4)	14–17 Yrs	Open Class (Hybrids allowed)	Engine must not exceed 239cc 2 stroke/299cc 4 Stroke

No Engine displacement reductions are allowed (sleeved down bigger engines to fit the cc criteria are not allowed)

Adult Mini Bike

Age on 1 Jan	Grade	Specification
15 years	Pro 88cc	Minibike open cradle frame, 4 stroke, horizontal engine upto 88cc, Semi Auto (no Manual Clutch) max wheel size 12" front 10" rear. Axle to axle measurement must not exceed 1150mm and maximum height Floor/Seat 750mm
15 years	Stock 110cc	Minibike open cradle frame, 4 stroke, horizontal engine upto 112cc, Semi Auto (no Manual Clutch) 20mm Carburettor, 2 valve only, Aframe Rear Swing Arm (none Mx Type) Telescopic Conventional Fork (none Inverted) max wheel size 14" front 12" rear. Axle to axle measurement must not exceed 1150mm and maximum height Floor/Seat 750mm
15 years	Pro 160cc	Minibike open cradle frame, 4 stroke, horizontal engine upto 160cc max wheel size 14" front 12" rear. Axle to axle measurement must not exceed 1210mm and maximum height Floor/Seat 840mm
21 years	Open	Minibike open cradle frame, 4 stroke, horizontal engine upto 212cc max wheel size 14" front 12" rear. Axle to axle measurement must not exceed 1210mm and maximum height Floor/Seat 840mm

Youth Mini Bike

Age on 1 Jan	Grade	Specification
6–8 years	Youth 50cc	Any 50cc off road bike 2 stroke or 4 stroke, horizontal or vertical engine, max wheel size 14" front 12" rear.
9–14 years	Youth 140cc	Minibike open cradle frame, 4 stroke, horizontal engine upto 140cc max wheel size 14" front and 12" rear. Axle to axle measurement must not exceed 1210mm and maximum height Floor/Seat 840mm

After reaching 15 years of age riders can apply for an adult solo Motocross licence and still retain a youth open licence until the end of the year in which their 18th birthday falls.

After reaching 15 years of age riders can apply for an adult quad Motocross licence and still retain a 250 youth licence until the end of the year in which their 18th birthday falls. (See 2.2 Capacity and Licence Restrictions).

2.3 YOUTH

1. Within the above limits youth riders will compete during the 2020 season in classes determined by date of birth. Riders may ride in a lower class for experience on a non-award basis.
2. No rider may compete before his/her fourth birthday.
3. When a rider reaches the maximum age limit for his/her group, he/she may continue to compete in that group until the end of the calendar year.
4. On reaching the minimum age for the next group, the rider may upgrade. Please note that any rider who chooses to upgrade cannot then move back to the lower capacity class once they have competed at the higher level. (With the exception of competing in the British MXY2 or Supercross Championships).
5. Any rider upgrading before the required minimum age is reached will be subject to disciplinary action unless officially upgraded by the Motocross Department.
6. An assessment will be required for any rider wishing to ride in a class of which they do not

reach the age requirement to be arranged by the rider following application to the ACU Motocross Department.

7. The parent or legal guardian must accompany a youth competitor under the age of 18 to any meeting and stay for the entire duration of the time that the rider is present.
8. Riders in possession of a Motocross Dual (youth open/adult MX) licence may compete in either youth or adult motocross events. Riders in possession of an ATV/Quad Dual (youth 250cc Adult Quad) licence may compete in either youth or adult motocross events. Riders must choose the class at the time of entry as it is not permitted to compete in both Youth and adults races at one meeting. (This is not applicable to Supercross)

2.4 ADULT

1. The parent or legal guardian must accompany a youth competitor under the age of 18 to any meeting and stay for the entire duration of the time that the rider is present.
2. No rider will be permitted to compete in the adult classes until they reach the minimum required age and hold the correct licence.

2.5 PHYSICAL ELIGIBILITY/PROFICIENCY ASSESSMENT

All youth riders should be able to sit astride their machines and with one foot firmly on the ground must be able to control the gear lever or the foot brake with the other foot.

SECTION 3 CLASS VARIATIONS

3.1 E4 CLASS

1. Clubs may not run the E4 class with any other class.
2. Parental persons must be signed on and wearing an appropriate identification bib or sash before entering any part of the course to assist their or any other rider. They are permitted to hold the rear of the machine immediately prior to the start of the race.
3. CIRCUIT
If being run on the full MX circuit the E4 class route must be clearly marked and risk assessed. If being run on a separate circuit located at the venue, then the Area/Circuit must be risk assessed and be no longer than 400m. and must be approved on the day by the Event steward or Clerk of the Course.
All other requirements under Motocross SRs such as officials, medical cover, protective clothing, helmets apply
4. RACES
Race lengths must not exceed 7 minutes. No mass starts. Maximum of 15 riders allowed to start in any one race
5. NON-SPEED EVENTS
All races will be considered as non-speed events although permitted by a motocross permit

3.2 AUTOMATIC CLASS

1. Clubs may run the Auto and Junior classes together. Electric machines with a maximum output of 8kw are only allowed in the auto class
2. Where there is direct conflict between large and small machines, clubs at their discretion may separate them into two classes.
3. Parental persons must be signed on and wearing an appropriate identification bib or sash before entering any part of the course to assist their or any other rider. They are permitted to hold the rear of the machine immediately prior to the start of the race.

3.3 65CC JUNIOR CLASS

Clubs may run the Junior 65cc and Auto classes together. Electric machines with a maximum output of 10kw are only allowed in the 65cc junior class.

3.4 85CC SMALL WHEEL AND 85CC BIG WHEEL CLASSES

Clubs may run 85cc Small Wheel and 85cc Big Wheel together.

3.5 YOUTH 125CC

Clubs may run the youth 125cc class and 125/250f class together. The 125cc class is not permitted to run in a joint class with any other classes or adult competitors. Clubs must stipulate in the event SRs if these two classes are run together or scored individually.

3.6 125/250F

The 125/250f Open Class may run with the 125cc class. The 125/250f Open Class may run with an adult class. Clubs must stipulate in the event SRs if these two classes are run together and must be scored individually.

3.7 MX2

120cc to 250cc twostroke or 175cc to 250cc fourstroke. Clubs may specify capacity restrictions for Championships within their event Supplementary Regulations. Electric machines with a maximum output of 16kw are only allowed in the MX2 class.

3.8 MX1

Over 175cc to 500cc twostroke or 251cc to 450cc fourstroke. Clubs may specify capacity restrictions for Championships within their event Supplementary Regulations.

3.9 OpEN (ADULT)

All solo machines 120cc twostroke or 175cc fourstroke up to 650cc two or fourstroke.

3.10 FORMULA CLASSES

For older machines can also be catered for at events i.e. pre-65, pre-75, twinshock, Evo (up to and including 1989) Super Evo (1990–1996).

3.11 50CC/100CC qUAD CLASS

50cc Quad class may be run with the 100cc Quad Classes but will not be permitted to run in a joint class with any other class. (Y1 & Y2)

3.12 150CC/250CC qUAD CLASS

150cc Quad class may be run with 250cc Quad Classes but will not be permitted to run in a joint class with any other class. (Y3 & Y4)

SECTION 4 LICENCES AND REGISTRATIONS (OFFICIALS)

Motocross Race Officials are required to hold an ACU Licence of the appropriate grade for the performance of their duties. The minimum age for motocross licensed officials is 18 years. Licences for officials will be issued free of charge.

4.1 LICENSED OFFICIALS

Motocross, Supercross, Beachcross and Minibike Officials who require a Licence.

	See Note Below	Licence Required	Attendance at Seminar/ Training Session
Clerk of the Course	1	YES	3 YEARS Every Third Year maximum
Race Director	National Only	YES	3 YEARS Every Third year maximum
Steward/Referee	2	YES	3 YEARS Every Third Year maximum
Chief Technical Officer	3	YES	3 YEARS Every Third Year maximum
Sound Inspector		YES	3 YEARS Every Third Year maximum
Measurer	4	YES	3 YEARS Every Third Year maximum
Timekeeper	5	YES	By Assessment

Clubs and Centres shall only nominate candidates whose aptitude and integrity for the position they can fully justify. Official ACU approval and the issue of a Licence is only after the candidates have proved to be competent according to the special requirements for each discipline. The respective Committees and Panels organise seminars that are compulsory for certain officials. A Licence, obtained following the successful completion of a seminar, is valid for 3 years.

4.1.1 CLERK OF THE COURSE/RACE DIRECTOR

- DEFINITION.** Refer to the National Sporting Code.
- AGE LIMITS.** There are no upper age limits for Motocross Clerks of the Course of all grades. A Clerk of the Course must be physically able to reach all parts of the circuit to carry out his or her duties.
- GRADES – Motocross/Supercross:**
 - National.** A Clerk of the Course who may officiate at any event held under an ACU permit. May officiate as Deputy or Assistant to an FIM International Clerk of the Course.
 - Regional.** A Clerk of the Course who may officiate at any event held under an Open or Restricted Permit.
- Upgrading.** To upgrade from Regional to National an official must have the recommendation of their club, centre or region or be recommended by the Motocross Committee.

4.1.2 STEWARD/REFEREE

- DEFINITION.** Refer to the National Sporting Code.
- GRADES**
 - There are two grades of licence for a Steward at Motocross events, National or Regional.
 - There is one grade of licence for a Referee at Supercross events, National.
- AGE LIMITS.** There is no upper age limit for Stewards/Referees at Motocross events. A Steward/ Referee must be capable of inspecting the entire circuit without assistance prior to the event starting. (A Steward could use an ATV for this purpose in Motocross).

4.1.3 CHIEF TECHNICAL OFFICER

- The Chief Technical Officer will be licensed by the Technical Department to be in charge of the technical control at an event. The Technical Department may restrict the disciplines of licence holders.

- A regional Technical Officer will be trained in a centre or region but will be registered through the ACU at Rugby and may take charge of a meeting of below National status.

4.1.4 MEASURER

The licence is issued by the ACU Technical Department and may be restricted by discipline.

4.1.5 TIMEKEEPERS

Timekeepers will be required to renew their Licence every three years.

4.2 UNLICENSED OFFICIALS

Motocross, Supercross, Beachcross and Minibike Officials who do not require a Licence.

Officials	Notes Attendance at Seminar/Training Session	
Incident Officer	1	None required
Secretary of the Meeting	2	Will receive training at events receive instruction from the Clerk of the Course
Technical Official		Will receive training via a Chief Technical Officer at meetings.
Club Stewards	3	May attend Regional or ACU HQ Seminars for information purposes
Chief Marshal		May receive training at ACU HQ or Regional Training Days
Marshal	4	May receive training at Regional Training Days and at meetings via the Chief Marshal.
Medical Officer	5	None required

- All other Technical Officials, Race Day Officials (e.g. Secretary of the Meeting, Incident Officer, Club Stewards) and Marshals may be registered, free of any charge. All such Officials may or may not be required to attend a Seminar. Registration will be renewed annually. Registered Officials and Marshals will receive an appropriate form of identification from the ACU.
- All assistant officials whose function is to be carried out at the immediate trackside must be at least 16 years of age.
- All assistant officials who are under 18 years of age must have obtained parental agreement to carry out the duty and the signing on signature must be countersigned by someone who is responsible for the official at the event.
- When using the services of minors (persons under 18 years of age) for any official duties at any event special attention must be given to any risks which may be associated with the duty, and to the previous experience of the official.

4.2.1 INCIDENT OFFICER

- Will collate all information and documentation, and prepare reports relating to serious accidents and to all incidents involving Officials or Spectators.
- A Deputy Clerk of the Course may undertake these duties. An Incident Officer may be nominated to attend a Clerk of the Course Seminar as part of their training.

4.2.2 SECRETARY OF THE MEETING

Will be responsible for all administration connected with the organisation of a meeting.

4.2.3 CLUB STEWARDS

Will together with the Chief Steward form the judicial authority over the running of the meeting.

4.2.4 MARSHAL

- All Assistant Officials or Marshals whose function is to be carried out immediate trackside must be at least 16 years of age with the exception of Marshals who are in membership of a

recognized military corps who must be at least 14 years of age. All Marshals who are under 18 years of age must have obtained parental agreement to carry out the duty and the signing on signature must be countersigned by someone who is responsible for the official at the event.

2. Flag Marshals must be provided with a tabard/waistcoat clearly identifiable.

4.2.5 MEDICAL OFFICER

See medical section of ACU Handbook.

SECTION 5 SPECIFICATION OF MOTORCYCLE

(CATEGORY 1) All Motorcycles in group A1 (Solo), B1 (Sidecar) and G (Quad) shall comply with the National Sporting Code Appendix D and the following:

5.1 BRAKES

1. Motorcycles must be equipped with one efficient brake operating on each wheel and be operated independently from the driving position.
2. For B1 (Sidecar) motorcycles brakes are not required on the sidecar wheel.
3. For group G (Quad) motorcycles brakes must be capable of operating, as a minimum, to both rear wheels.

5.2 TYRES

1. There is no restriction as to the tyres that may be used other than as may be laid down in the Supplementary Regulations but chains and other non-skid devices will not be permitted.
2. Scoop or paddle (continuous radial rib) tyres and/or tyres with lugs having a height of more than 9.5mm are forbidden.

5.3 MUDGUARDS

Category A (Solo) and B (Sidecar) motorcycles must be fitted with two mudguards giving protection to the driver. The rear mudguard must cover 35 degrees of the upper rear wheel.

5.4 CLUTCH AND BRAKE LEVERS

1. Clutch and brake levers must be, in principal, ball ended, the diameter of the ball to be at least 12.5mm.
2. This ball can also be flattened but in any case the edges must be rounded.
3. These ball ends must be permanently fixed to form an integral part of the lever.

5.5 FOOTRESTS AND HANDLEBARS

The ends of the footrests must be rounded with a radius of not less than 8mm. The ends of the handlebars on all motorcycles shall be rounded or otherwise protected. Handlebars must be equipped with a protection pad on the cross bar. The handlebars without cross member must be equipped with a protection pad located in the middle of the handlebars, covering widely the handlebars clamps. For group G (Quad) motorcycles nerf bars must be fitted.

5.6 LAMPs

1. For motorcycles group A1 (Solo) and B1 (Sidecar) lamps, registration plates and licence holders must be removed.
2. For motorcycles group G (Quad) direction indicators and mirrors must be removed. Other glass or plastic lenses must be taped, padded with foam rubber, or equivalent, at least 25mm thick and taped again.

5.7 THROTTLE

All machines must be fitted with self-closing throttles.

5.8 EXHAUST pipes

1. The end of the exhaust pipe or pipes must not project beyond any part of the vehicle or its bodywork.
2. Exhaust gasses must not be discharged so as to raise dust or foul the tyres or brakes or inconvenience a following driver.
3. A provision for the discharge of waste or surplus oil must be made so that it is collected and not spilt onto the circuit.
4. Breathers can be routed into air boxes or collector tanks.

5.9 RUNNING OF ENGINES

1. The running of engines is prohibited except during official practice, actual racing, sound testing and for a period not exceeding five minutes prior to the start of each race.
2. A breach of this regulation may involve disqualification from the meeting of the rider of the motorcycle concerned.

5.10 FUEL

For Fuel specifications please refer to Fuel Regulations section of the ACU Handbook.

5.11 IGNITION CUT-OUT

1. Motorcycles in group A1 (Solo) used in Motocross will be fitted with an engine cut-out button.
2. Motorcycles used in group B1 (Sidecar) will be fitted with an engine cut out button that must be operated by a non elastic string or cord (coil telephone wire is not permitted). The cord should be a maximum of 500mm. Any part of the cut-out that remains live when disconnected must be shrouded in order to prevent accidental contact with any part of the motorcycle.
3. Motorcycles in group G (Quad) will be fitted with an engine cut out button that must be operated by a non elastic string or cord. Any part of the cut-out that remains live when disconnected must be shrouded in order to prevent accidental contact with any part of the motorcycle.

5.12 CHAIN GUARDS

1. For motorcycles group A1 (Solo) and B1 (Sidecar) the manufacturer's original guards or parts of similar design must remain in place. However machines pre 2000 may be exempt from this rule. See national Sporting Code.
2. For group G (Quad) motorcycles an adequate guard must be fitted to prevent any accidental contact with the primary chain or any part of the run not in contact with the sprocket. See National Sporting Code.

5.13 CONSTRUCTION

The use of titanium alloy nuts and bolts is allowed. But a dimension increase may be necessary when non-ferrous fasteners replace ferrous fasteners.

5.14 WHEELS

1. For all groups wheels with six or less spokes must be guarded.
2. For motorcycles group B1 (Sidecar)
 - a. The three wheels shall each be of at least 400mm (16") in diameter measured over the outside of the tyre.
 - b. The wheel track, or lateral distance between tracks, shall be no more than 1150mm.
3. For motorcycles group G (Quad) the measurement from the front wheel to its following rear wheel must be equal.
4. Titanium Spindles are not allowed.

5.15 ENGINES

For motorcycles group G (Quad)

1. The engine must drive either or both rear wheels and must drive both rear wheels when competing against quads.
2. The engine must be behind the front wheel(s) and central in front of a line between the rear wheel centres.

5.16 ELECTRIC MOTORCYCLES

1. The technical concept is reserved for motorcycles propelled by non-thermal energies with zero toxic/noxious emissions and by the action of one wheel in contact with the ground. Amendments to these technical regulations may be made at any time in order to ensure fair competitions.
2. Two and/or three wheeled electric propelled machines, powered solely by stored electricity (battery/accumulator). The number of electric motors is limited to two.
3. E4 Class - An electric motor with a maximum output of up to approximately 1.5 kw measured at the back wheel
Automatic class - An electric motor with a maximum output of up to 8 kw measured at the back wheel
65cc Class - An electric motor with a maximum output of up to 12 kw measured at the back wheel
MX2 Class - An electric motor with a maximum output of up to 16 kw measured at the back wheel
4. The charging system must be separate from the machine and comply with all electrical safety requirements including thermal overload trip, fusing and be equipped with an earth leakage protection breaker.
5. The Technical Steward shall check both the machine and the rider for compliance with the technical specifications, as well as the employment of good engineering construction practice, and the presence of adequate electrical insulation and weatherproofing.
6. All motorcycles must comply in every respect with all the requirements for racing as specified in the ACU General Technical Specifications, unless otherwise specified below.

Chain/Belt Guards

Chain/Belt Guards must be fitted to prevent any accidental contact with the primary chain/belt as a safety measure. The chain/belt guard must be fitted to protect the front and rear sprockets **Number Plates and Colours**

See SR 6.9.

Colours: Green background – yellow numbers.

Machine Weight

E4 class Minimum weight: 30kg. The maximum weight limit shall not exceed 40kg.
Automatic Class Minimum weight: 30kg. The maximum weight limit shall not exceed 40kg. 65cc Class Minimum weight: 50kg. The maximum weight limit shall not exceed 60kg.

MX2 Class Minimum weight: 75kg. The maximum weight limit shall not exceed 120kg.

Accumulator (storage battery)

The accumulator is defined as any equipment used for the intermediate storage of electrical energy supplied by the charging unit. Any on-board accumulator is considered as an integral part of the vehicle's accumulator.

The type, dimensions and weight of accumulator/s cannot be changed between official practices and race.

All on-board electrical equipment, unless consisting of items originally powered by dry batteries, small accumulators or their own solar cells, must receive its energy supply from the vehicle's official accumulators.

IMPORTANT: As a condition of entry, a Material Data Safety Sheet must be supplied with

the race entry for the machine, including all relevant details as to the accumulator chemistry, human and environmental hazards, handling and specific fire risks and precautions.

Energy recovery

Recovering energy generated by the kinetic energy of the vehicle is permitted.

Use of outside energy sources

The use of any carbon based source of energy in any form whatsoever with the aim of improving the performance of the vehicle is strictly prohibited. This includes the energy used to drive the vehicle's cooling system.

Inclination

It must be possible for a motorcycle, not being loaded, to be inclined to an angle of 40° from the vertical, without any part of it other than the tyre coming into contact with the ground. In race conditioned the motorcycle must be capable of affecting a standing start on an uphill slope with a gradient of 18%.

IEC Publications (Guidelines)

If no specific rule exists in these Technical Rules, the relevant IEC Standard (International Electro-technical Commission Standard) or Report has to be observed:

- a) IEC 60529 Degrees of protection provided by enclosures (IP Code).
- b) IEC 60783 Wiring and connectors for the road vehicles. This report is applicable to cabling and connectors used in battery electric road vehicles.
- c) IEC 60784 Instruments for electric road vehicles. This report is applicable to the instrumentation of electric road vehicles, excluding those items which are used as instrumentation in vehicles with internal combustion engines.
- d) IEC 60785 Rotating machines for electric road vehicles. This report is applicable to rotating electrical machines [traction motors and auxiliary motors] of electric road vehicles including hybrids, which are fed from the main traction batteries).
- e) IEC60786 Controllers for electric road vehicles. This report is applicable to the equipment on electric vehicles that control the rate of energy transfer between the traction battery or batteries and the motor or motors).

Operating Voltage

The voltage is limited to 500 volts nominal between two points (ie. higher charging voltages are permitted).

Propulsion system failure

The vehicle must be able to freewheel in the event that the propulsion system has stopped (i.e. fuel/charge exhausted or system failure).

General circuit breaker – 'Emergency Stop'

Two emergency stop switches (circuit breakers/Kill switch) are required as a stop has to be easily accessible both to the rider and to marshals.

When seated in a normal riding position, the rider must be capable of interrupting all electrical transmission between the accumulators and the energy consumers by means of a spark-proof general circuit breaker/kill switch situated in front of him. This breaker must be located in such a way that it can be also operated from outside the vehicle.

This breaker must be clearly identified as such.

The use of a lanyard attached to the rider to operate this breaker/switch as an alternative to a button is recommended.

The general circuit must also include a second general circuit breaker/kill switch which When the motorcycle is in powered on state, there must be a clear visual indicator showing on the rear of the machine. This must be a flashing red light mounted on the rear bodywork and be visible from at least 10 metres away, from the side or rear. The light must flash between 1 and 2 times/ second on a 50% duty cycle.

Power control

A 'self-closing' throttle (power control) must be applied.

5.17 MISCELLANEOUS

1. For motorcycles group B1 (Sidecar) a passenger must be carried in addition to the driver.
2. Provision for the riders seat must be forward of a line between the rear wheel centres and above and/or behind the engine, to give the rider, when seated, full and safe control of the machine.
3. For motorcycles group G (Quad) bumpers and nerf bars must have all corners with a radius of a minimum of 12.5mm.

SECTION 6 NUMBER PLATES

1. Number plates will be a minimum of three in number on all machines and it is the rider's responsibility to ensure that the numbers are clearly visible.
2. No metallic or reflective colours may be used in any circumstances.
3. Plates and numbers must comply with the following requirements.
 - a) They must be made of a rigid material and solidly constructed.
 - b) The front plate should measure a minimum of 285mm × 235mm in size with a minimum of 50mm radius rounded corners.
 - c) The plates must be flat or slightly curved (not more that 25mm (1") from the true plane) and must not be otherwise bent or obscured in any way.
 - d) The front plate may be perforated but on no account may the numbers be perforated.
4. One plate must be carried facing forward and not more than 30 degrees from the vertical with one on each side of the machine.
5. Side number plates must be positioned above a horizontal line drawn through the rear spindle and behind a line drawn vertically at a minimum distance of 200mm behind the footrest. The size will be as accepted by the FIM.
6. The minimum dimensions of the front number plate numbers should be: height 140mm (5⁵/₈"), width 80mm (3⁵/₈"), width of stroke 25mm (1") and the space between any two figures 15mm (5/8"). The minimum dimension of the side number plate numbers will be 100mm.
7. The Clerk of the Course has the discretion to disqualify any rider not showing legible numbers or discounting any appeal resulting from illegible numbers.
8. For motorcycles group G (Quad) a third number plate must be fitted with a minimum size of 150mm × 150mm mounted behind the rider on the rear grab bar, and be in line with the machine reading left to right on both sides. The mounting bracket must not be higher than 150mm. Height of the number 100mm. Width of the number 80mm. Width of stroke 25mm. Space between two numbers 15mm.
9. The colours shall be as follows: The figures and background must be in a 'matt' (non-shiny) colour.

Front & Side Plates	Background Colour	Number Colour
Adult		
100cc to 145cc 2 stroke/125cc – 250cc 4 stroke	Black	White
146cc – 650cc 2 Stroke/251cc – 650cc 4 stroke	White	Black
Electric	Green	Yellow
Sidecars	Yellow	Black
Quads	White	Black
Youth – Solo		
Electric Youth	Green	Yellow
Automatic – 65cc Junior	Black	White
85cc Small Wheel (Intermediate)	Red	White
85cc Big Wheel (Senior)	Green	White
125cc	Blue	White
125/250f	Black	White

Youth – Quads

50cc (Y1)	White	Black
100cc Auto (Y2)	Blue	White
100cc Open (Y2)	Red	White
150cc Open 2–150 (Y3)	White	Black
250cc Air Cooled (Y3)	Blue	White
250cc Open (Y4)	Red	White

Minibike Adult

Pro 88	White	Black
Stock 110	Blue	White
Pro 160	Green	Black
Open	TBA	TBA

Mini Bike Youth

50cc	Black	White
140cc	White	Black

Any other number plate or any marking on the motorcycle that might be confused with a number plate must be removed before the rider is allowed to start.
 The only exception to the number plate regulations will be where special conditions apply to a National, Centre or Club Championship series and are explained in the Supplementary Regulations or conditions to that series.

Numbers for minibike racing must not exceed 2 digits, (i.e. 1–99)

6.10 NUMBER PLATE DIAGRAM

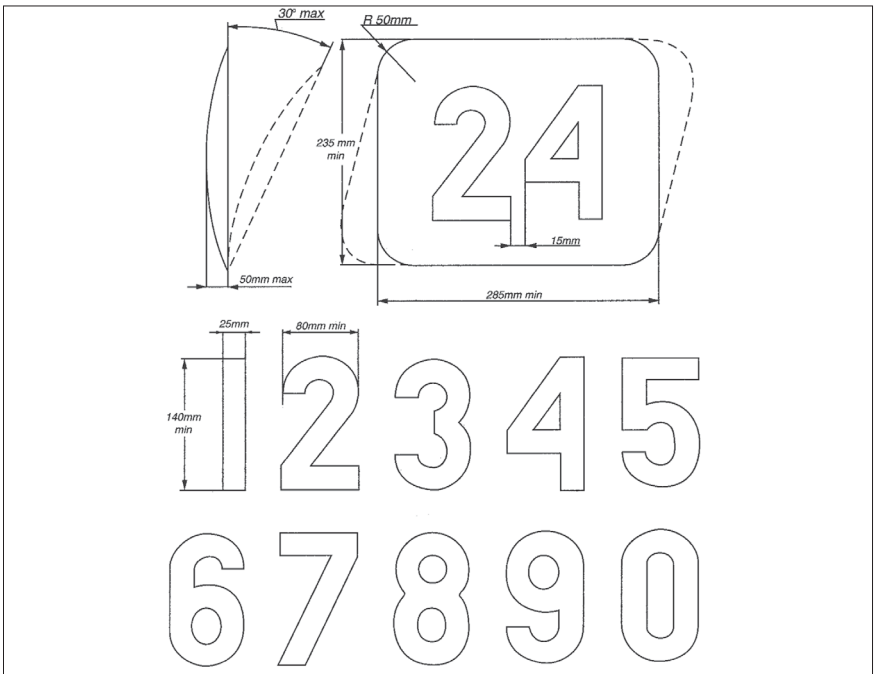

SECTION 7 TECHNICAL CONTROL

1. All motorcycles, helmets and protective clothing must be presented to the Technical Officer as requested, for examination before the start of any practice or at any time during the meeting as may be required by the Clerk of the Course to ensure that they comply with the requirements of the regulations.
2. Any machine damaged in an incident can be recalled by the Technical Officer for re-inspection before being ridden again at the meeting.
3. Any bike fitted with additional side panels or streamlining must have such panels removed when presented for a noise test.
4. Every motorcycle finishing in a race must, if so required, be submitted for final examination and any motorcycle may be retained by the promoters for such a period as may be reasonably necessary for its examination.
5. Where it may be necessary for promoters to verify any fact, this shall be carried out at the cost of the rider. If a rider refuses to release his machine to be measured by the officials of the meeting than this action will result in automatic disqualification from the event.
6. In the event of a protest against machine specification where an engine has to be stripped an additional fee of £250 for four stroke and £150 for two stroke machines MUST be submitted with the protest and protest fee. In the event of the protest being upheld the additional fee will be returned. If the protest is not upheld the additional fee will be awarded to the other party and will be the only costs payable.
7. Sound Level Control:

Two tests will be in operation.

1. Static Test – For all machines pre 2010.
2. The FIM 2 Metre Max Test – For machines post 2011.

Solo

- For machines 2013 and onwards – maximum sound limit 112dB/A (+2 dB/A before each race, +3 dB/A after the race) tested using the 2 Metre Max method. Type 1 and Type 2 meters.
- For 2010–2012 machines – maximum sound limit 115 dB/A (+2 dB/A before each race, +3 dB/A after the race). Tested using the 2 metre max method. A further review will be made at the end of 2020.

Sidecars

Maximum sound limit for 2 stroke engines at 112 dB/A (+2 dB/A before the race, +3 dB/A after the race). For 4 stroke engines at 115 dB/A (+2 dB/A before the race, +3 dB/A after the race) tested using the 2 Meter Max method. A further review to be made at the end of 2020.

Quads

Maximum sound limit 112 dB/A (+2 dB/A type 1 & 2 meters before each race) (+3 dB/A type 1 & 2 meters after each race) tested using the 2 Metre Max method. A further review to be made at the end of 2020.

Procedure

All machines shall be sound tested using the 2 Metre Max method, the exceptions being Twin Shock and Evo Classes, the Static Test method will prevail with a test limit. 96 dBA for 2 strokes and 94 dBA for 4 strokes, using fixed RPM according to the list below, with the exception of the 500cc class.

Up	to	85cc
		8,000rp
m	Over 85cc up to	125cc
		7,000rp
m	Over 125cc up to	145cc
		6,500rpm
	Over 145cc up to	250cc
		5,000rpm
	Over 250cc up to	500cc
		4,500rpm
		500cc
		4,000rp

m

There is no 2 stroke/4 stroke rev differential below 500cc. Due to the influence of temperatures on sound tests, all figures are correct at 20°C. For tests taken at temperatures below 10°C there

will be a + 1 dBA tolerance. For tests below 0°C, a + 2 dBA tolerance. There will be a + 2 dBA tolerance allowed for post race sound tests. **Machines Post 2011**

The FIM 2 Metre Max Test Method will be enforced as previously detailed. The maximum sound limit accepted: 115 dBA+ 1 dBA post race.

A sound level of 81 dBA at 100 metres during racing should be attained.

8. The Clerk of the Course may disqualify or penalise any rider of a machine which exceeds the maximum permitted sound level, or which in his opinion is deemed to be excessively noisy.
9. Random or spot checks may be made by ACU Sound Control Officials of the sound level of any machine taking part in any ACU meeting in addition to any routine checks at technical control.

SECTION 8 SAFETY

8.1 MEDICAL SERVICES

At all Motocross events, including official practice, qualified first aid personnel must be in attendance with full first aid equipment. Organisers must ensure sufficient medical services for the type of event remain in place until the event has completely finished.

For National and International Events a Medical Officer or Paramedic must be in attendance. For all other status events A Medical Officer (MO) or a Paramedic (PM) or an IHCD Emergency Technician (EMT) or the Voluntary Aid Society (VAS) equivalent must be in attendance during official practice and racing.

The minimum requirement for the start of every event is two ambulances.

If one of the two ambulances has to leave the circuit then the minimum requirement for the event to continue is one ambulance and one Medical Officer (MO) or Paramedic (PM) or IHCD Emergency Technician (EMT) or the Voluntary Aid Society (VAS) equivalent, plus enough qualified first aid personnel to cover the course layout size and type of event subject to medical requirements shown below and/or specified on the TTC.

For clubs running events at Centre Restricted level and below and where there are less than 119 rider entries the minimum medical requirements are One ambulance – On the condition the ambulance is available at all times. Should the ambulance be required to support the treatment of, or transport an injured rider the meeting must stop until such time that the ambulance is available again. The ambulance should be accompanied by either a Medical officer (MO) a Paramedic (PM) or IHCD Emergency Technician or the VAS equivalent. Plus enough qualified first aid personnel to cover the course layout, size and type of event subject to medical requirements as shown in this Handbook.

It is recommended to all event organisers that any Medical Service/Personnel appointed should supply ambulances that are CQC-registered.

1. If only one ambulance is listed as the minimum requirement at an event then organisers are reminded that if it has to leave the event then all practising and racing must stop until its return or replacement. It is incumbent therefore on organisers of events to remember their commitment and duty of care to competitors in ensuring that sufficient medical services for the type of event, dictated by a risk assessment of the expected number of injuries, are in place prior to the start of practising and racing and remain in place until the event has completely finished.
2. Auxiliary vehicles, such as 4x4 with a stretcher, cannot replace an Ambulance but such vehicles might, at certain event sites, be used in addition to and as the final form of transportation to the Ambulance for the event.
Note A 4x4 vehicle can be an ambulance if registered with the DVLA as an ambulance.
3. If there is a requirement for first aid personnel to be present then they can be the two crew members of an Ambulance, assuming that one is present as a minimum requirement, but they must be available for all the practices and races. Such first aid personnel are an additional requirement to any doctors or paramedics required to be present at the meeting.

4. If there is a requirement for full first aid equipment, including a stretcher, then this can be the same equipment as that defined in the minimum equipment requirements for an Ambulance.
5. If the minimal medical cover required is for only one Doctor or only one Paramedic to be present then, if the only one available has to leave, for whatever reason, the practices or races must stop until their return or replacement.
6. If a Doctor is required at an event then they must be on site. It is not sufficient to have the name and address of a distant doctor, who would or might be available if required.
7. The nearest hospital, with an Accident & Emergency Department, must be notified in writing of the time, date and place of the meeting.
8. If a Doctor is involved in the treatment of competitors or spectators at an event, they should not normally be involved with drug or alcohol testing of competitors.
9. If a medical centre is available at a circuit or the site of an event then it should be fully operational and independently staffed. If deemed acceptable, an Ambulance or similar unit may act as a medical centre but if so, it must be additional to the minimum Ambulance requirements.
10. If no Medical officer or Paramedic is required at an event then at least one of the two Ambulance crew must be qualified as an IHCD Emergency Technician or the VAS equivalent, rather than just a first aid person.
11. If a competitor is involved in an incident involving potential injury, but is not, at the time, taken to Hospital for further treatment, then a relative, or a member of their crew, should be given a copy of the medical assessment or Ambulance report form completed by the event medical personnel following the incident.
12. **Concussion/suspected concussion**
If a competitor is involved in an incident which results in him being diagnosed by the Medical Officer/Paramedic as suffering from concussion or suspected concussion, the rider is not permitted to participate any further in that event.
Organisers are to notify ACU Head Office as soon as possible of any concussion/suspected concussion injuries and then will subsequently:
 - a) Place the rider on the ACU Stop List
 - b) Inform Organisers of forthcoming events that the Rider has suffered a concussion/ suspected concussion injury and is therefore placed on the ACU Stop List
 - c) Inform the Rider that he needs to see a Doctor and obtain a letter/doctor's certificate which confirms he is fit to resume competitive racing/participate in a practice/test session.The recovery time for anyone diagnosed with concussion/suspected concussion is as follows:
 - a) Over 20 years: Excluded immediately and suspended for a period of nine days.
 - b) 16-19 years: Excluded immediately and suspended for a period of twelve days.
 - c) 15 and under: Excluded immediately and suspended for a period of twenty three days. The rider is not permitted to ride during the obligatory suspended periods outlined above and then only once he is in possession of a doctor's certificate/letter after the suspended period has expired.Exceptionally for the Maxxis British Motocross Championships only, a rider may be signed off to ride by the CMO of the event after observing the obligatory suspended period outlined above.
If a competitor has been injured on a Saturday and is suffering from concussion/suspected concussion, and the Organiser is aware that the rider was intending to ride or is scheduled to ride somewhere else the next day, the Organiser will inform the Organiser of the event being held the next day so they are aware of the rider's injuries and as such he is prevented from participating in that event.

8.2 CLOTHING

1. All competitors must wear a helmet. For information regarding helmets please refer to the helmet section within this Handbook.
2. Competitors are advised not to wear hand, face or body jewellery/piercings which could prove hazardous in the event of an accident.
3. The mouth should be kept clear of anything likely to cause blockage of the airway in the event of an incident, e.g. chewing gum. This includes removing false dentures.
4. It is not advised that bulky hard objects such as tools etc. are carried in pockets or on the person.
5. Goggles or visor of a non-splinterable type must be worn at the commencement of each race. Spectacles, if worn, must be non-splinterable.
6. The use of "Tear Off" lenses on goggles is at the discretion of the event organisers. It must be stipulated in the event Supplementary Regulations if they are allowed or not for each individual event.
7. The carrying of on board cameras on helmets is only permitted with prior approval of the Chief Technical Officer or Clerk of the course. The Camera used must automatically be released from its fixing in the event of a crash. The fixings should be of the flat "pad type" and not have any uneven or high elements to it.
8. It is compulsory that riders/passengers wear, as a minimum, back and chest protectors, soft shell body armour is acceptable, incorporated within the suit or worn separately. It is advised that all riders and passengers should wear a body belt/kidney protector.
9. It is the responsibility of the rider's parent/guardian to ensure that all protective clothing is correctly fitting for youth competitors.

8.2.1 MOTOCROSS, SUPERCROSS AND BEACHCROSS

In all races and official practice complete protective clothing produced for motocross racing, knee length boots and gloves shall be worn by each rider and passenger. It is advised that motocross jerseys should provide protection against abrasion to the body and arms and that motocross jeans are padded at the hips and knees.

8.2.2 MINIBIKE

In all races and official practice complete protective clothing shall be worn by each rider. It is advised that Ankle boots should reach above the ankle ball. Ankle braces laced up properly and fit closely could be worn under the boot to increase stability. Jerseys should provide protection against abrasion to the body and arms. If short sleeved jerseys are worn then elbow pads must be worn to protect exposed skin. Trousers/shorts must provide protection to the knee, shin and hips. If Motocross style shorts are worn then they must cover the knee and must be used in conjunction with a knee, shin pad combination.

8.3 TRACK SAFETY

See ACU Requirements for Safety Precautions at all Motocross Events held under an ACU Permit 2020.

8.4 FIRE EXTINGUISHERS

All competitors must have a 2kg (minimum) dry powder fire extinguisher available for immediate use. If a 'closed vehicle' is being used the extinguisher must be fitted adjacent to, or on the inside of the working door. In the case of a shared vehicle the other competitors extinguisher(s) should also be visible, or, the fitted extinguisher(s) must be of a proportionately larger capacity. All extinguishers must have a current certificate attached.

8.5 RIDING IN THE Paddock

Riding of machines in the paddock is strictly prohibited and warning signs should be erected. Machines should be pushed with the engine dead. Riding of machines at a slow pace can be permitted if designated lanes are provided. Machines must be pushed upon exiting from any point on these lanes. Riding to and from the Paddock – In exceptional circumstances or if permitted by the Clerk of the Course riders must not exceed first gear idle when travelling to and from the paddock area and must always wear a helmet.

8.6 TRACK ACCESS

Strictly no personnel, other than signed on officials, are permitted on the track while machinery is operating.

8.7 FLAG SIGNALS

The following flag signals will be used:

National Flag	This flag can be used for starting a race.
Red	All Riders must stop. Riders must not pass any red flag unless authorised or directed to do so and then proceed at a slow pace.
Black with the riders number clearly shown on a board	That rider to stop racing immediately and leave the track.
Yellow Motionless	Danger, take care. ride with caution.
Yellow Waved Marshals are only advised to wave their flags when riders are stopped on the course in a dangerous position or being attended to by officials or medical staff	Great Danger, prepare to stop, no overtaking. A significant reduction in speed must be seen, therefore jumps should not be attempted.
Green	Riders under starter's orders.
Blue	Warning you are about to be lapped.
Yellow with Black Cross	Last Lap./(either or) a two lap and then one lap board, clearly marked.
Chequered	Finish.
White with Red Diagonal Cross Raised & Motionless	Medical attention required at that post.
White with Red Diagonal Cross Waved For National Adult and Youth events only.	Medical Crew & Officials in attendance on live race track. Proceed with extreme caution, riders must significantly reduce speed and roll each jump individually with no overtaking until past the area of concern

N.B. 'Waved' shall mean a flag should be moved up and down through an arc of 45 degrees and not indiscriminately.

Only authorised officials are permitted to use these flags. Any rider who is judged to have taken unfair advantage whilst a yellow flag is displayed and waved, or ignored any other flag signal, may be disqualified. All of the above flags should measure not less than 750mm x 600mm.

SECTION 9 RACE MANAGEMENT

9.1 ENTRIES

A motorcycle sport entry form must be completed and signed by each entrant, rider or

passenger. All riders, passengers and appointed persons responsible for minors must register arrival at an event by signing on at the event race office or designated area.

9.2 pRACTICE

1. Time must be put aside for the practice sessions and these must be defined in the Supplementary Regulations for the meeting.
2. Riders will commence practice under the instructions of the start officials and must join the circuit from the designated area.
3. The duration of practice will commence from the time when the first rider joins the circuit.
4. The waving of the chequered flag will indicate the end of practice.
5. For any race there must be a minimum period for practice on the actual course, the details of which must be stated in the Supplementary Regulations.

9.3 START pOSITIONS

1. Start positions will be established according to the provisions of the Supplementary Regulations.
2. Where the organisers decide the grid positions will be by ballot this must be conducted by the competitors at the meeting.

9.4 ELECTRONIC TIMEKEEPING

1. Only licensed ACU, MSA or equivalent Timekeepers can time a qualification practice where qualification to a final, a series of races, or start line positions is the determined outcome. Organisers must inform competitors if times are official or unofficial. The Chief Timekeeper should be stated in Supplementary Regulations, official programmes and on all results sheets provided.
2. Electronic lap scoring equipment does not require official timekeepers to operate a system but it is advised that manual lap scoring is carried out to support an electronic system.
3. If timed practice is used and identical times are recorded by more than 1 rider in the official qualifying practice session for the race the rider first setting such a time will receive the better starting position.
4. Transponders, if used, should be fitted to the machine as per the timekeepers or manufacturers instructions, it is the rider's responsibility to ensure that the correct transponder is securely fitted, it is the rider's responsibility if a transponder is lost from the machine during an event.

9.5 RACES

1. The race category and durations should be stipulated in the Supplementary Regulations.
2. In the event of a race being cancelled due to insufficient entries, the promoters reserve the right to offer the race time and prizes for a race of similar length for machines of another class or suitable category.

9.6 METHOD OF STARTING

The method of starting shall be stated in the Supplementary Regulations.

9.7 STARTER'S ORDERS

1. Riders are deemed to be under starter's orders when the first rider is called to the start line, signified by the raising of a green flag.
2. Riders in the 65cc or 85cc SW class will be allowed assistance from the start line officials if necessary, by raising their hand, to activate their launch control devices. This procedure is not deemed compulsory.
3. Any rider causing a start to be unnecessarily delayed in the opinion of the starter and/or the Clerk of the Course may be disqualified.

4. No persons will be allowed in the start area once riders have come under orders at the start line, except riders, passengers and authorised officials.
5. Once the riders are under starter's orders, the start procedure should not commence until the circuit is clear, signified by the lowering of the green flag.
6. If a 15 and 5 second board is used the following procedure will be followed:
 - The 15 second board will be displayed for a full 15 seconds.
 - The 5 second board will be displayed for a full 5 seconds.
 - The gate will drop between 5 and 10 seconds after the "5 seconds" sign is shown.

9.8 FALSE STARTS

All false starts shall be indicated by the waving of a red flag, all riders will have to go back to the starting area and await announcements regarding the restart.

9.9 STOPPING A RACE

1. If a race is stopped before the leader has completed three laps, the race may be re-run at the discretion of the Clerk of the Course.
2. If a race is stopped under 50% of the race distance excluding any additional laps and over 3 laps completed by the leader the result will be taken at the end of the penultimate lap during which the signal to stop the race was given, a minimum of three laps must be shown on the completed race result. The race may be re-run at the discretion of the Clerk of the Course.
3. If a race is stopped after 50% of the race time has elapsed, excluding any additional laps, the result will be declared on the last completed lap.
4. In the event of a race being re-run the Clerk of the Course may disqualify any rider or riders who is/are the prime cause of the race initially being stopped.
5. If a race has to be stopped after the leader has completed 50% of the race distance, excluding any additional laps, rounded down to the nearest number of laps, it will be considered to have finished.
6. a) The order of classification shall be based upon the order of last crossing the finishing line prior to the showing of the red flag and only competitors who are racing at the showing of the red flag will be classified.
b) If a race has to be stopped after the leader(s) has taken the chequered flag they will be classified as having finished the race. The order of classification for those riders who have not taken the chequered flag shall be based upon the order of last crossing the finish control line prior to the showing of the red flag and only competitors who are racing at the showing of the red flag will be classified.
c) The Clerk of the Course may disqualify/penalize a rider from the results who has deemed to be the cause of the red flag incident.
7. For Adult National races to be classified as a finisher, riders must have completed 50% of the total laps completed by the race leader, or as per the Supplementary Regulations.
8. For Youth National races to be classified as a finisher, riders must have completed 50% of the total laps completed by the race leader, or as per the Supplementary Regulations.
9. Only the Clerk of the Course or his assigned assistants can stop a race, all courses must have sufficient assistants to ensure that when a race is stopped this decision is communicated to all of the riders as quickly as possible. A TCC can state how many assistants are required for a course and if radio communication is required.
10. For British Championship races please refer to the Supplementary Regulations.

9.10 FINISH OF RACE

1. The chequered flag will be displayed as the winner crosses the finish control line and will be kept flying thereafter until the last riders finish the lap.
2. No rider will be allowed to start a fresh lap after the chequered flag has been displayed.

3. Riders crossing the finish control line will be flagged off, their position being determined by the number of laps each has completed, those riders who complete a similar number of laps having their positions determined by the order in which they cross the finish control line or appear on the final results. A rider does not have to cross the finish control line to be classed as a finisher within the time limit as laid down in the Supplementary Regulations.
4. If the chequered flag or last lap flag is mistakenly displayed later than the official time/distance, the finishing order shall be determined by the running order at the official time/distance. Under any circumstances, such as mistaken display of the chequered flag or last lap flag before the official time/distance, the finishing order shall be determined by the running order at the time the chequered flag is displayed.

9.11 RACE RESULTS

1. If the results are to be decided on points, the points allocation must be clearly defined in the Supplementary Regulations along with the method of deciding ties.
2. When a race has been completed the results will be based on the order in which a rider crossed the finish control line and the number of laps completed.
3. Should a tie occur on an overall result the highest position in the final leg will determine the final order.
4. It is the rider's responsibility to check the official results board/sheets for his finishing position and/or any penalties issued.
5. Series of Championship rounds - If the Championship Regulations allow for race results to be dropped then a rider who receives disqualifications during the year will not be allowed to consider/count them as one of his worst individual results etc. If a rider receives penalties during the year this could be considered/count as one of his worst individual results.

9.12 CHANGE OF MACHINE

A change of machine may be permitted provided the machine has been through Technical Control procedure. The same machine must be used throughout any one race.

9.13 CHANGE OF SIDECAR PASSENGER

1. The only reason to change a passenger is injury and only one change per meeting will be allowed.
2. The passenger must sign on, have the correct licence, and complete a sighting lap.
3. Application for a change must be in writing to the Clerk of the Course at least 30 minutes before the start of the race.
4. The final decision will be left with the Clerk of the Course.

9.14 OUTSIDE ASSISTANCE

1. If during a race a rider and/or passenger receives outside assistance other than that provided by the Organisers for the removal of himself or his machine from the course in the interests of safety, that rider may be disqualified.
2. Riders receiving signals from persons associated with them in prohibited areas may be disqualified.
3. The use of two way radios with a rider/passenger is prohibited.
4. Only riders who are competing in the race on the circuit are insured. Signed on riders who are not competing in the session on circuit are treated as spectators.

9.15 FOUL, UNFAIR OR DANGEROUS RIDING

The Clerk of the Course may penalise any rider who, in his opinion, is guilty of unfair, foul or dangerous riding.

9.16 COURSE CONDUCT

1. If, for any reason, a rider leaves the course, they must rejoin it as closely as possible at the point where they left the course without any outside assistance. They must not gain any advantage. If any advantage is obtained they may be penalised or disqualified from the results.
2. If any rider leaves the track boundaries they shall not be allowed to re-join the race.
3. Riders must at all times adhere to the direction of racing. Exception may be given when this cannot be achieved due to the nature of the terrain. The decision of any such exception will in the first instance be judged by the Clerk of The Course or Race Direction.

9.17 AWARDS

1. Awards of any description must be described in the Supplementary Regulations; the method of distribution must be announced before the completion of the event.
2. Awards for youth riders in youth events: Cash, gift vouchers, and goods are only permitted in the group A1 Open class and group G (Quad) 250cc Open Youth classes.

SECTION 10 GENERAL

10.1 INSTRUCTIONS TO RIDERS

Any Supplementary Regulations or instructions to riders subsequently issued, shall have the same force as these Standing Regulations but must in no way contradict these Standing Regulations.

10.2 CONDUCT

Riders, parents or associates failing to obey instructions given by officials of the meeting or deemed to have unjustifiably or maliciously jeopardised the efficient running of the meeting by not adhering to the Regulations, Supplementary Regulations or the protest procedure, may be disqualified from the meeting.

See also the National Sporting Code, Offences and Penalties.

10.3 PARENTAL RESpONSIBILITY

It is a parent's or guardian's responsibility to ensure that children stay within the confines of the event site and obey all instructions issued by the organiser.

10.4 DECLARATION

It is a condition of acceptance of entry that the promoters shall not be responsible for any damage to a motorcycle or its accessories whether by fire, accident or other causes, nor for the theft of a motorcycle or its accessories before, during and after the meeting.

10.5 COMPLIANCE WITH REGULATIONS

Every rider by entering or being entered or nominated, thereby acknowledges that he is bound by the National Sporting Code of the ACU and these Standing Regulations together with any Supplementary Regulations or Conditions and Final Instructions to be hereafter issued, to all of which he undertakes to submit and, moreover, renounces any right to have recourse to any arbitration or tribunal not provided for. All safety precautions for ACU Motocross events are available in a separate publication from the ACU.

10.6 DOGS AT OFF ROAD MOTORCYCLE EVENTS

Whilst dogs are not discouraged from attending Off Road Motorcycle Sport events, they are to be kept on a lead and under control at all times. Owners are responsible for ensuring their dog is kept under control and are responsible for clearing up any fouling that may occur.

SECTION 11 BEACHCROSS

11.1 SpECIFICATION OF MOTORCYCLE

All machines must comply with the appropriate specification applicable to the type, that is to say, Trial, Trail, Enduro, Motocross or ATVs. Paddle or scoop tyres are strictly forbidden.

11.2 LpG FUEL/DIESEL

Vehicles using LPG fuel must comply with the LPGA Code of practice 11. for auto gas installations June 2001, and will be subject to refuelling regulations, including a minimum 11kg fire extinguisher. Diesel fuel must be 'roadside pump' available.

11.3 CIRCUIT

Hazards should become progressively harder around the circuit so that large numbers of riders are not stopped at the first hazard on the first lap. A number of flag marshals must be placed at each obstacle subject to the pre race risk assessment.

11.4 STARTER'S ORDERS

A rider shall be deemed to be under starter's orders when he collects his machine from the parc ferme/waiting zone.

11.5 FINISH OF A RACE

The chequered flag will be displayed as the winner crosses the finish control line and will be kept flying thereafter until the last rider finishes that lap. No rider will be allowed to start a fresh lap after the chequered flag has been displayed. Thereafter riders crossing the line will be flagged off, their position being determined by the number of laps each has completed, those riders who complete a similar number of laps having their positions determined by the order in which they finished within the time limit laid down in the Supplementary Regulations will be declared finishers. The organisers reserve the right to declare in the Supplementary Regulations the distance required to be declared a finisher.

11.6 DURATION OF A RACE

As specified in the Supplementary Regulations.

11.7 INTERRUpTION OF A RACE

The Clerk of the Course for reasons of safety may temporarily stop the event by the waiving of a red flag at any point on the circuit. The race will resume on the raising of the green flag by the Clerk of the Course.

11.8 DISqUALIFICATIONS

Any rider considered for disqualification may be allowed to complete the race and be disqualified, subject to protest and appeal procedures. If in the opinion of the Clerk of the Course the offence is undisputable the rider can be disqualified from the race immediately. The Clerk of the Course must write down the time, details of the offence and time of the disqualification to be given to the Stewards as soon as is possible.

SECTION 12 CROSS COUNTRY QUADS STANDING REGULATIONS

12.1 MEETINGS

12.1.1 DEFINITION

Cross Country events are controlled Group Start events which are a test of endurance and reliability. Competitors will be required to complete a number of laps within a time set by the organisers. The duration of events will be stated in the Supplementary Regulations.

12.1.2 PROCEDURE FOR STOPPING AN EVENT

Where it is deemed necessary to stop an event, only the Clerk of the Course or his assigned assistants can stop an event. All courses must have sufficient assistants to ensure that when a race is stopped this decision is communicated to all of the riders as quickly as possible.

12.2 ELIGIBILITY

12.2.1 ELIGIBILITY

All Adult riders must hold a current ACU or SACU licence and be a minimum age of 15 years. Any rider from another FMN MUST produce a licence issued by their FMN together with start permission and proof of personal accident insurance.

Day Licences. A one event Competition Licence grants the same benefits of an annual licence for the duration of the one event and is available for up to and including National Status.

Youth rider may compete in these events but must be a minimum of 7 years of age and a maximum of 16 years and is restricted to a maximum machine capacity of 250cc.

12.2.2 CAPACITY & RESTRICTIONS

Subject to the Supplementary Regulations any quad machine which complies with the Motocross Specifications as per the current ACU Handbook, may be allowed.

Adults +15 yrs

C1: Championship	For machines up to 550cc max 2 cylinder 2 stroke or up to 800cc 4 stroke max 1 cylinder
C2: Experts	For machines up to 550cc max 2 cylinder 2 stroke or up to 800cc 4 stroke max 1 cylinder
C3: Clubman	For machines up to 550cc max 2 cylinder 2 stroke or up to 800cc 4 stroke max 1 cylinder
C4: Utility & 4x4	For machines up to 550cc max 2 cylinder 2 stroke or up to 800cc 4 stroke max 1 cylinder

Youth Quad

Max cc	Age	Type	Specification
50cc (Y1)	7–9 yrs	Automatic Quad	Performance Modifications are allowed up to a maximum of 50cc. Engine must not exceed 50cc at time of Manufacture.
100cc Auto (Y2)	8–13 yrs	Auto, 100cc Production Quads built by the manufacturer	Engine must not have exceeded 100cc 2 Stroke Auto/150cc 4 Stroke Auto
100cc Open (Y2)	9–13 yrs	Open Geared Class Max 100cc 2 Stroke/150cc 4 Stroke	Engine must not have exceeded 119cc 2 Stroke/179cc 4 Stroke.
150cc Open 2–150 (Y3)	11–16 yrs	Open Geared Class Max 100cc 2 Stroke Air Cooled/150cc 4 Stroke Water Cooled	Engine must not exceed 119cc 2 Stroke/179cc 4 Stroke. 150cc Open 2 Class compete in the 250cc Race Group
250cc Air Cooled (Y3)	11–16 yrs	Air Cooled Production Quads	Performance Modifications are allowed to the Engine & chassis up to a maximum of 239cc 2 Stroke/299cc 4 Stroke. Frame & Engine must be by the original Manufacturer. Engine must not exceed 239cc 2 stroke/299cc 4 Stroke
250cc Open (Y4)	14–17 yrs	Open Class (Hybrids allowed)	Engine must not 239cc 2 stroke/299cc

			4 Stroke
--	--	--	----------

No engine displacement reductions are allowed (sleeved down bigger engines to fit the cc criteria are not allowed)

12.3 CLASS VARIATIONS

12.3.1 VARIATIONS

The Youth class must be run as a separate session from any Adult classes at the same event and must not be combined with any Adult classes at the same event. Youth capacity/Age/ability classes must be stated in the supplementary regulations.

12.4 LICENCES AND REGISTRATIONS (OFFICIALS)

As per Motocross Standing Regulations.

12.5 SPECIFICATION OF A MOTORCYCLE

Category G (Quad) shall comply with the National Sporting Code appendix D and the following:

12.5.1 MOTORCYCLES

Subject to the Supplementary Regulations any Quad which complies with the Motocross Specifications as per the current ACU Handbook may be allowed.

12.5.2 TYRES

Tyre type is optional or as stated in the Supplementary Regulations.

12.6 NUMBER PLATES

All Quad machines must be fitted with a front & rear number plate of a minimum size of 150mm × 150mm with the rear mounted behind the rider on the rear grab bar, and be in line with the machine reading left to right on both sides. The mounting bracket must not be higher than 150mm. Height of the number 100mm. Width of the number 80mm. Width of stroke 25mm. Space between two numbers 15mm.

Adult Quads	Background Colour	Number Colour
C1: Championship	Red	White
C2: Experts	Green	White
C3: Clubman	Yellow	Black
C4: 4x4 Utility	White	Black
Youth Quads		
50cc (Y1)	White	Black
100cc Auto (Y2)	Blue	White
100cc Open (Y2)	Red	White
150cc Open 2–150 (Y3)	White	Black
250cc Air Cooled (Y3)	Blue	White

12.7 TECHNICAL CONTROL

1. As per Motocross Standing Regulations.
2. **Helmets** – Helmets bearing the ACU gold or silver stamp, in sound condition and properly fitted must be worn by all competitors. Please refer to the section in this Handbook titled 'Helmets' for other important information and conditions concerning European Community Exemption.
3. **Jewellery** – Competitors are advised not to wear hand, face or body jewellery which could prove hazardous in the event of an accident. The mouth should be kept clear of anything likely to cause a blockage of the airway in the event of an accident, e.g. chewing gum. This includes removing false dentures.
4. **Noise control** – Machines must be within the noise levels currently in force for that category of machine (see respective Standing Regulations).

12.8 SAFETY

12.8.1 MEDICAL SERVICES

As per Motocross Standing Regulations.

12.8.2 CLOTHING

As per current Motocross/Enduro Standing Regulations.

12.8.3 FIRE EXTINGUISHERS

All competitors with the exemption of those travelling to an event on the machine on which they are competing, must have a 2kg (minimum) dry powder fire extinguisher available for immediate use.

If a 'closed vehicle' is being used the extinguisher must be fitted adjacent to, or on the inside of the working door. In the case of a shared vehicle the other competitor's extinguisher(s) should also be visible, or, the fitted extinguisher(s) must be of a proportionately larger capacity.

12.9 RACE MANAGEMENT

12.9.1 COURSE

Must be 'off-road' and the minimum time should be set in the Supplementary Regulations. The organisers may split the event into 2 or more legs if desired but the minimum time for each leg must be set in the Supplementary Regulations. The ratio of competitors to course will be – 30 riders per km of course, e.g. 180 riders must have 6 km lap distance etc.

Any restrictions on the number of machines used by Team riders are to be stated in the Supplementary Regulations. All machines used are to be subject to Machine Examination.

For the Y5 Beginner production class organisers must ensure visual contact is applied at each rider at all times.

Special attention should be given to riders in this class for fatigue during the race.

The organisers must also ensure that each rider entered in this class is able to reasonably control their machine and should be identified by the wearing of a high visibility bib.

12.9.2 START

The start must be set out so that riders will start in groups which will be decided by the organisers e.g. capacity classes, ability classes etc. These groups will be defined in the Supplementary Regulations.

The number of riders in each group – which must not exceed 40 – and the start interval between groups – which must be no less than 30 SECONDS – will be decided by the organiser and due regard to course layout and the approval of the permit issuing authority. The organisers must ensure that the entire entry must be able to start and leave the start area before earlier riders start subsequent laps. In all circumstances there must be a dead engine start. This may limit the size of entry. Any rider who fails to start their machine at the allotted start time for their group will be credited for that original start time regardless of the actual time that they start. Start procedure will be stated in the Supplementary Regulations.

12.9.3 LAP SCORING AREA

An area must be designated which allows riders to pass through single file gates where their number will be recorded on the completion of every lap. Where there is more than one class the organiser may set alternative durations to suit the varying abilities. The organisers may stipulate that riders have to stop. The lap scoring area will be deemed as a "Blue Tape" area and marked as such.

12.9.4 FINISH

After the specified time/number of laps, the riders will be diverted through the lap scoring area and then from the course.

12.9.5 FINISHING ORDER

The winner overall and of any respective classes will be the riders who have achieved the closest number of laps to the duration set on the allotted time. Each riders start time will be taken as their respective groups start time, or individual start time as decided by the Organiser and their individual finish time will have been recorded.

12.9.6 FINISH OF RACE

1. The chequered flag will be displayed as the winner crosses the finish control line and will be kept flying thereafter until the last riders finish the lap.
2. No rider will be allowed to start a fresh lap after the chequered flag has been displayed.
3. Riders crossing the finish control line will be flagged off, their position being determined by the number of laps each has completed, those riders who complete a similar number of laps having their positions determined by the order in which they finish.
4. Only riders crossing the finish control line within the time limit laid down in the Supplementary Regulations will be declared as finishers.
5. For all Adult National races. To be classified as a finisher, riders do not have to cross the finish control line, but riders must have completed 50% of the total laps completed by the race leader, or as per the Supplementary Regulations.
6. For all Youth National races. To be classified as a finisher, riders do not have to cross the finish control line but riders must have completed 50% of the total laps completed by the race leader, or as per the Supplementary Regulations.

12.9.7 TIES

Will be decided on the laps completed and the individual times of each rider.

12.9.8 CHECKS

The start/finish will be the only time check. There should be adequate marshals/route checks on the course to prevent course cutting.

12.9.9 MARSHALS

Organisers should place marshals at strategic points around the course to monitor safety and ensure control of event. Additional clearly identified Travelling Marshals can also be used to achieve this.

12.9.10 PUBLIC SPECTATOR AREAS

The Supplementary Regulations must announce the provision of clearly identified specific areas which must be used by all non competitors other than riders or officials. Warning notices must be placed at appropriate points around the course to prevent public access.

12.9.11 RESTRICTED SPEED (BLUE TAPE) AREAS

These areas MUST be established on the approach to the Time Control/Lap Scoring area and any Re-fuelling and works areas. Within 'BLUE TAPE' areas the rider must not exceed walking pace, under Penalty of exclusion. The Incident Officer/Clerk of the Course may also establish 'BLUE TAPE' areas at other parts of the course if required.

12.9.12 RE-FUELLING

A suitable and restricted area must be marked out adjacent to the course as a pit area. Access to this area must be restricted to marshals, riders and authorised helpers. The area should be manned by marshals and access only allowed to officials, competitors and authorised helpers. The Organiser MUST establish a fire point, clearly indicated and with the appropriate fire extinguishers present. Each rider shall ensure that his re-fuelling crew, have a fire extinguisher at the re-fuelling point as described in Regulation 3.13. 'No Smoking' signs should be displayed. **THE ENGINE MUST BE STOPPED AND THE RIDER OFF THE MACHINE DURING REFUELLING. NO SMOKING ALLOWED. REFUELLING MAY ONLY BE CARRIED OUT IN THE DESIGNATED AREA.**

12.9.13 OUTSIDE ASSISTANCE

1. If during a race a rider and/or passenger receives outside assistance other than that provided by the Organisers for the removal of himself or his machine from the course in the interests of safety, that rider may be disqualified.
2. Riders receiving signals from persons associated with them in prohibited areas may be disqualified.
3. The use of two way radios with a rider/passenger is prohibited.

Assistance will only be allowed in the pit area, except when provided on the course by the organisers.

12.10 GENERAL

12.10.1 ENTRIES

A Motorcycle Sport Events Entry Form must be completed in every detail, and signed by each entrant, rider. (N.B. a requirement of signing and entry application form is that each signatory understands the National Sporting Code of the ACU, Standing Regulations, such Supplementary Regulations as have been issued for the event and such Final Instructions subsequently issued, and agrees to be bound by them).

Limitations of Entries. If entries are to be limited, the maximum number and method of limitation (i.e. in order of receipt, by ballot etc.) Will be stated in the Supplementary Regulations.

Child Protection. The point of contact for Child Protection issues will be the Secretary of the Meeting unless otherwise stated in the Supplementary Regulations.

12.10.2 ACCEPTANCE OR REFUSAL OF ENTRY

The Organiser must notify all riders of the position regarding their entry prior to the event. The method for notification will be stated in the Supplementary Regulations for the event.

12.10.3 PUBLIC WARNING

Notices must be displayed in accordance with the Safety Precautions section of the current ACU Handbook.

12.10.4 DOGS

Whilst dogs are not discouraged from attending Off Road Motorcycle Sport events, they are to be kept on a lead and under control at all times. Owners are responsible for ensuring their dog is kept under control and are responsible for clearing up any fouling that may occur.

12.10.5 COMPLIANCE WITH REGULATIONS

Every rider by entering or being entered or nominated, thereby acknowledges that he is bound by the National Sporting Code of the ACU and these Standing Regulations together with any Supplementary Regulations and Final Instructions to be hereafter issued, to all of which he undertakes to submit and moreover renounces any rights to have recourse to any arbitrations or tribunal not provided for.

SECTION 13 GRADING

13.1 ACU MOTOCROSS RIDERS EXPERT GRADING SCHEME (ADULT)

Expert status will be given to riders who appear on the Expert list compiled by the ACU Office. You can qualify for Expert Listing by the following means:

- Point scorer in an adult National Motocross Championship.
- Registered Rider in the ACU British MX Championship – MX1/MX2.
- Top 10 point scorer in the British Youth Championship – 125/250f class (Open).
- Selected by Centre Recorders based on Regional or Club Championships.
- Upgraded by the Motocross Committee.

Riders may be removed from the list after two years if they have not scored any regional or national Championship points.

UPGRADING TO INTERNATIONAL

Sidecar Competitors – There will be no grading for sidecar competitors.

Quad Riders – There will be no grading for quad riders.

The Central Recorder for the Motocross Grading Scheme is:

Mrs S Goggin, ACU House, Wood Street, Rugby, Warwickshire, CV21 2YX. Tel: 01788 566404.

SECTION 14 MOTOCROSS MOTORCYCLE

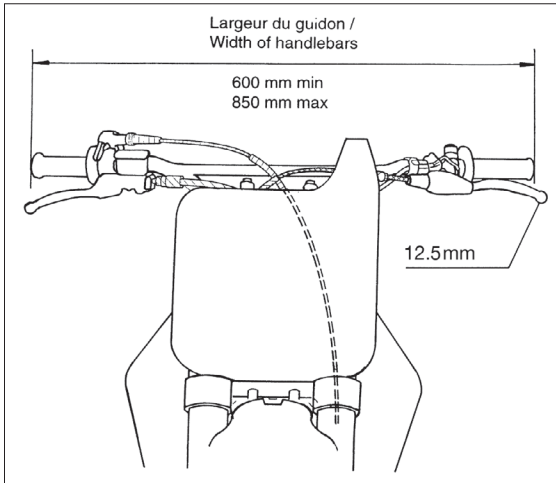
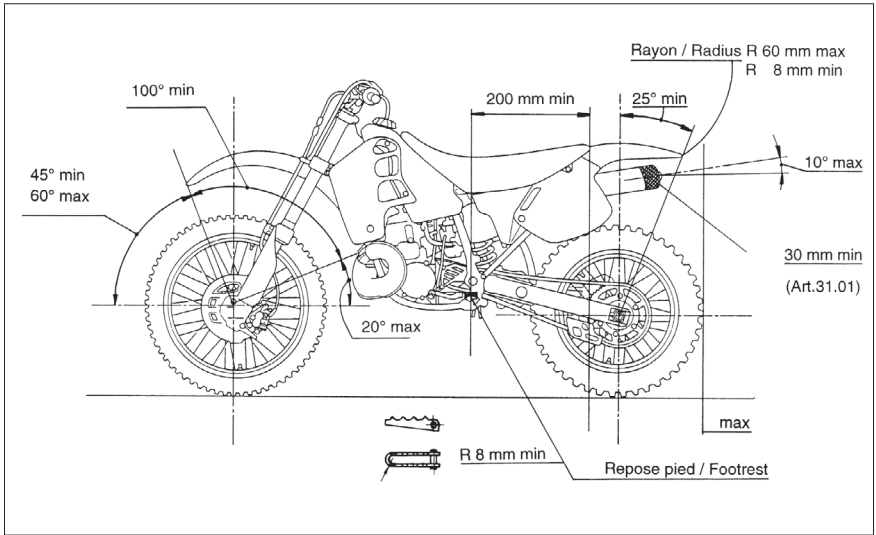

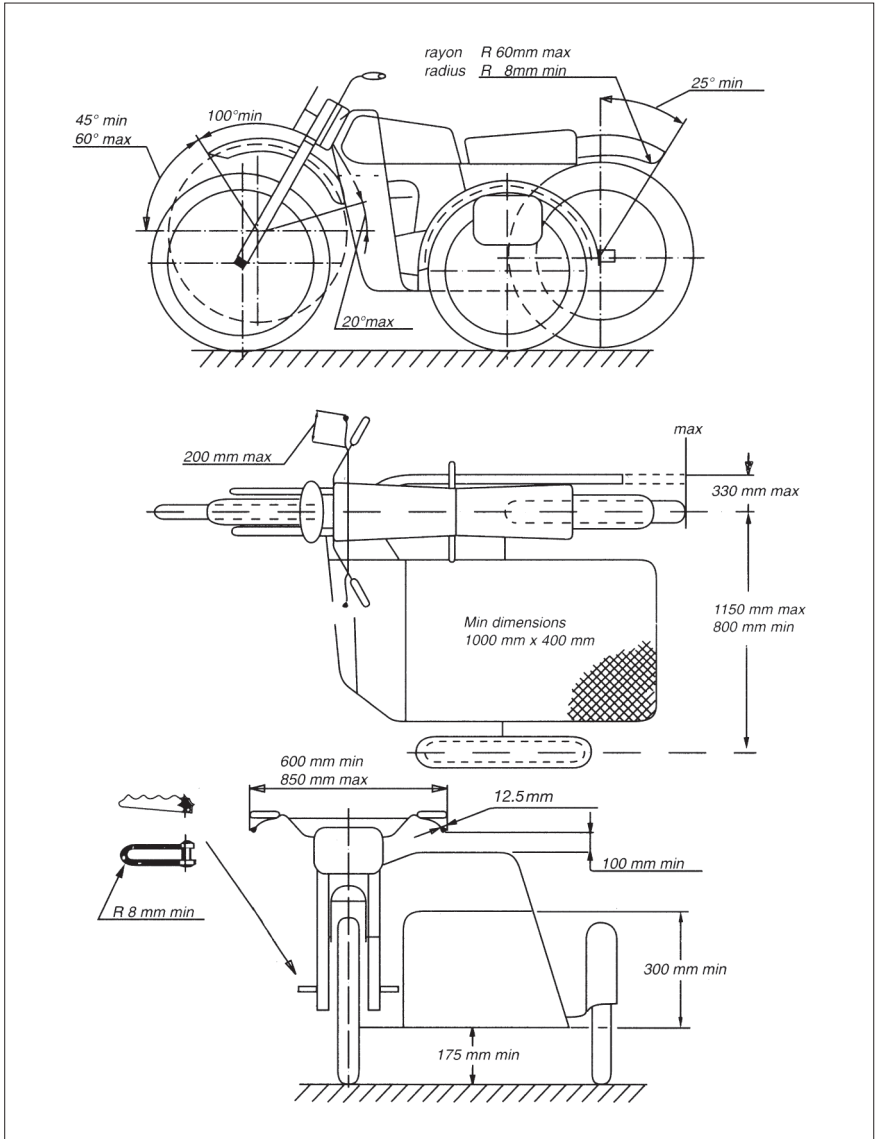

Enduro

Standing Regulations

DEFINITIONS	140
ENDURO STANDING REGULATIONS	140
GENERAL	140
TIME CARD ENDURO STANDING REGULATIONS	141
APPENDIX A DIAGRAM OF MACHINE	154
APPENDIX B PENALTIES	155
ALL TERRAIN (RALLY) REGULATIONS (ATR)	156
SHORT COURSE TIME CARD ENDURO STANDING REGULATIONS	164
HARE AND HOUNDS/CROSS COUNTRY STANDING REGULATIONS	165
ENDURO OFFICIALS	169

DEFINITIONS

Time Card Enduro Events where riders start separately (or in groups up to 4), the main part of the event is to ride the course, which is predominately off road, within time allowances which are achievable and timed to the nearest Minute. The event includes Special Tests where riders start individually and are timed to fractions of a second. The lap length is a minimum of 10 miles with Special tests up to 15% of the length of the lap.

Short Course Time Card Enduro Events similar to the above with a reduced length of lap greater than 2 miles and less than 10 miles and where the Special Tests may consist of the whole or part of the lap however the total length of special tests must not cover more than 20% of the total length of the Course.

Extreme Enduro an off-road event over extremely difficult terrain where riders start individually or in groups of 2 or more where the result is decided on the rider who completes the most laps in the set time or the greatest number of laps in the shortest time.

Off Road Sprint Enduro an off-road event where riders start individually and consist of a series of Special Tests where the time is taken to 1/000 second. The event being decided on the sum of the time penalties achieved over the set number of Special tests.

All Terrain (Rally) Events an event staged over varied terrain, predominantly Forest Roads and Tracks, and is intended to prove the skill and endurance of riders and the reliability of their machines. The event is aimed at production Trail motorcycles of all capacities and the route shall be planned accordingly and will consist of several liaison stages or legs. The inclusion of Timed sections or Special stages is optional however the riders must start such tests individually.

The route may be marked with route markers, or may require the competitor to use navigational skill or may require a combination of both.

Hare & Hounds/Cross Country Event an off-road event where riders start in groups where the result is decided on the rider who completes the greatest number of laps in the shortest time.

Note There are restrictions regarding the start number/procedure for this type of event on Forestry land.

ENDURO STANDING REGULATIONS

GENERAL

AUTHORISATION AND LAND USE

The contents of "Procedures and safety arrangements for events using Forestry Agreement land" must be adhered to for any appropriate events.

1. Events depend on goodwill from landowners, local authorities, nearby residents and other users of the countryside. For the continuance of orderly motorcycle sport, a Code for Time and Regularity Events, formulated by LARA, has been adopted by the ACU. The Code is reproduced below and will supplement the Standing Regulations. It is to be noted that where necessary disciplinary action will be taken if the Code is not fulfilled.
2. Any Competitive event that is routed along, or across, footpaths or bridleways must be endorsed in advance by the Highways Authority for the area.
3. The Organiser is responsible for obtaining authority from the landowners over whose land the event passes.

4. Where the event requires use of public highway, organisers must ensure that the Motor Vehicles (Competitions and Trials) Regulations 1969 are strictly adhered to. Events requiring authorisation must obtain this through the Motor Sport Association, Authorisation Dept.
Events organised within the restraints of section 5b. of the 1969 act must inform the local police authority and act according to their instruction.
5. The Organiser is responsible for ensuring the event meets all requirements of the Road Traffic Act.
6. The Organiser should appoint an officer responsible for event liaison. The Liaison Officer should, if appointed submit his name and address to the local Highway Authority, the Parish Council, the Police and landowners over whose land the event passes. The Liaison Officer will thoroughly investigate any complaints and try to resolve any problems arising from the event.
7. Wherever possible the Liaison Officer should maintain good relations with other path users in the area, such as horse-riders, walkers, cyclists, recreational motoring groups and orienteers. The Liaison Officer shall notify these groups in advance of an event where they are known to him.
8. The Liaison Officer shall be responsible for the provision and removal of signing for public safety in accordance with the guidance given on the relevant Safety Precaution pages of this Handbook. He should ensure that all marshals are adequately briefed about the public's rights and the purpose of the signs.
9. All officials, marshals, support crews and competitors must follow the Country Code.
10. Ensure that all aspects of the ACU Environmental Code are adhered to.
11. Supplementary Regulations should include a map reference or post code relating to the venue in order to assist the Emergency services.
12. Owners are responsible for ensuring their dog is kept under control and for clearing up any fouling that may occur.

The appropriate Standing Regulations will apply to all events together with the ACU National Sporting Code and Supplementary Regulations issued.

TIME CARD ENDURO STANDING REGULATIONS

ESR.1 ELIGIBILITY

All riders and passengers must hold a current ACU or SACU competition licence, and be aged 16 years or over.

Any rider or passenger from another FMN MUST produce a licence issued by their FMN together with start permission and proof of personal accident Insurance.

Where the Enduro includes the use of public highways, then this will be stated in the Supplementary Regulations. If public highways are used, then it is sole responsibility of the rider to ensure that his machine is roadworthy and that he and his machine comply with all legal requirements.

ESR.2 ENTRIES

A Motorcycle Sport Event Entry Form must be completed in every detail, and signed by each entrant, rider or passenger. Each completed entry form, together with the entry fee (which includes insurance premiums), shall be forwarded to the Secretary of the Meeting. Details of the name, address and telephone fax number of the Secretary of the Meeting (or a deputy), all entry fees, closing date for entries, conditions for return of fees, and any other special requirements, may be obtained from the event Supplementary Regulations.

All riders and passengers must register arrival at an event by signing-on at the event control office, or other designated area, not less than 30 minutes prior to commencement of said competition.

Riders and Passengers under 18 years of age (Minors): In order to conform with the Children Act legislation, for every rider or passenger who is under 18 years of age an additional Parental Agreement Form must be signed by either the parent or legal guardian or a responsible adult (who

need not be the rider's parent) dependent on age. The Parental Agreement is incorporated in the Annual Competition Licence and Trials Registration form and once completed will serve as the riders Annual Parental Agreement. All minors will be bound by the directions of parent(s), guardian(s) or an appointed adult responsible for them at any event. The following should be noted for Minors aged 16 or 17:

The Parental Agreement must be signed by a parent or legal guardian. There is no requirement for the minor to be accompanied to events by an adult.

Child Protection. The point of contact for Child Protection issues will be the Secretary of the Meeting unless otherwise stated in the Supplementary Regulations.

ESR.3 ACCEPTANCE OR REFUSAL OF ENTRY

Within 3 days of the official closing date, the Organiser must notify riders of the definite position regarding their entry and whether such entry has been accepted, or is being held in abeyance, or has been refused. The closing date of entries, the conditions for return of Entry Fees and any other special requirements will be contained in the Supplementary Regulations. All Supplementary Regulations must carry the telephone number of a responsible official.

Limitations of Entries. If entries are to be limited, the maximum number and method of limitation (i.e. in order of receipt, by ballot etc.) shall be stated in the Supplementary Regulations. Events using Public Highways are limited to 180 competitors, except for exempt events. See MSA (Competitions and Trials) Regulations.

Change of rider. All entries will be deemed to be in respect of the rider so named and no change of rider will be permitted except in the case of "Team Only" competitions where the Team Entry is

submitted by a Team Manager. For "Team Only" competitions any change of an individual entry will be subject to the conditions of the Supplementary Regulations.

ESR.4 INSTRUCTIONS TO RIDERS

Any instructions subsequently issued must be approved by the Permit Issuing Authority if issued prior to the event, or approved by the Stewards of the meeting if issued at the event. They shall have the same force as the Standing Regulations and the Supplementary Regulations, provided they are issued by one of the following methods:

- Issued in writing and distributed to each rider;
- Issued via a clearly situated notice board;
- Via a rider briefing meeting, providing all riders have been informed of the venue and time of such a meeting.

ESR.5 CLASSES

Time Schedules and/or Routes may vary between classes – details will appear in the Supplementary Regulations or as indicated in methods detailed above.

Solo. There are five recommended classes:

- (1) Championship
- (2) Expert
- (3) Clubman
- (4) Women
- (5) Sportsman, for beginners on a no awards basis.

Quads and/or Sidecars. A class for quads and/or sidecars may be included where the organiser has assessed that the course is suitable for that class of machine.

Supplementary Regulations must give details of any other classes.

CAPACITY GROUPS

E1 2 stroke – Up to 125cc

E1 4 stroke – Up to 250cc

E2 – Over 125cc to 250cc two-stroke & Over 250cc to 450cc four-stroke

E3 – Over 250cc two-stroke & Over 450cc four-stroke

Any or all the above capacity groups may be included as quoted in Supplementary Regulations. Organisers have the option of including additional classes or splitting classes but this must be quoted in Supplementary Regulations.

Sidecar. There are three recommended classes:

- (1) Championship
- (2) Expert
- (3) Clubman.

Organisers have the right to combine classes subject to sufficient entries.

Sidecar Capacity Groups. Unlimited capacity.

Teams Events. Details of provision for nominated teams will be given in the Supplementary Regulations.

It is recommended that team results are worked out on the number of special tests ridden by clubman, plus rider's time lost on the course, in the normal way.

ESR.6 CHANGE OF MACHINE AND/OR PASSENGER

- Prior to the Start
Any change of machine within the same capacity group and/or passenger must be notified to the Secretary of the Meeting a minimum of 24hrs before the start of the Competition. Any restrictions regarding change in the capacity group of a machine must be detailed in the Supplementary Regulations.
- During the event (including multiple day events)
The same machine and passenger (where appropriate) must be used for the duration of the event.

ESR.7 MOTORCYCLES

Machine Specification: Solo class category 1 group A1. Sidecar class category 1 group B1 and B2. **FOR DIMENSIONS SEE APPENDIX A AT THE END OF THE ENDURO STANDING REGULATIONS IN THIS HANDBOOK.**

The front light shall take the form of a combined headlight and number plate as fitted on an Enduro machine.

Brake and Clutch levers. All handlebar levers (clutch, brake etc.) must be in principle ball ended. These ends must be permanently fixed and form an integral part of the lever.

Brakes: Independent brakes must be fitted to both front and rear wheels of the motorcycle.

Disc Brake Covers It is recommended that the front brake disc has a cover over at least the leading edge of the disc.

The responsibility is on the rider to ensure that his motorcycle complies with all legal requirements including horn, speedometer. All motorcycles must be fitted with working lights.

Organisers may mark the following parts with paint which are inscribed with their number: (i) Main frame (ii) Both hubs. (iii) Silencers (If the competitor replaces the silencer during the event he must request for it to be remarked at the next time check). At the end of the event machines should be examined for marks.

ESR.8 TYRES

Front and rear – Unless otherwise stated in the Supplementary Regulations tyres must be 'Enduro' type to current FIM specification with DOT or E mark imprinted (see diagram at the end of Enduro Section).

Please note: Some Motocross Tyres do not comply with Road Traffic Act Regulations and are not permitted for events using the Public Highway. Only tyres which appear on the tyre manufacturers range catalogue or tyre specification list as suitable for use on the Public Highway for the motorcycle

entered, may be used. They may be of Trial, Trail or Enduro pattern with a depth of tread not more than 13mm at the time of manufacture.

Tyre Change: Inner tubes/mousses may be replaced at any time during the event or in a multi-day event where a work area is provided but not whilst the bike is in parc ferme. Tyres may only be changed at the day's final time check between the white and yellow flag

ESR.9 FUEL

Commercially available unleaded fuel must be used. Power boosters or octane boosters are forbidden.

ESR.10 CONTROL OF EXHAUST SOUND LEVEL

It is the sole responsibility of the rider to present a machine complying with all Road Traffic Act(s) requirements including exhaust sound level.

The 2-metre max test will be used. The maximum sound limit accepted will be 112 dBA before the Start (+2 dB/A during or after the event). (For precise method of testing, see Sound Control Regulations in this Handbook).

There may be one or more sound level tests taken during the event at any point on the route, as close as practical following a time check or refuelling area.

A rider who has changed his silencer must get it remarked at the next time check.

Any rider who fails the sound level test will face immediate disqualification and hand in his time card. At any time during the event, the Clerk of the Course or their appointed official is empowered to disqualify any machine they consider to be excessively noisy.

ESR.11 RIDER'S NUMBERS

Riders must provide their own numbers which must be a minimum height of 100mm.

Championship Class – Red plates with white numbers on the front and sides.

Expert Class – Green plates with white numbers on the front and sides.

Clubman Class – Yellow plates with black numbers on the front and sides.

Women's Class – Pink or Purple plates with black numbers on the front and sides. **Sportsman Class** – Black plate with white numbers on the front and sides.

Veterans Class – Blue plate with white numbers on the front and sides.

If an organiser intends to provide numbers and/or plates this must be detailed in the Supplementary Regulations/Final instructions. If these are supplied by the organiser they must be used by the riders and any associated logos/advertisement not obliterated

ESR.12 EXAMINATION OF MACHINES

Machines will be examined before the start to ensure compliance with the Standing Regulations and ACU Technical Specifications.

Organisers may mark the following parts with paint which are inscribed with their number:

1. Main frame.
2. Both hubs.
3. Silencers

If the competitor replaces the silencer during the event he must request for it to be remarked at the next time check.

At the end of the event machines should be examined for marks.

ESR.13 ENGINE MEASUREMENT

Where it becomes necessary for the ACU or the Clerk of the Course to verify any fact relating to an engine size, it shall be carried out at the cost of the rider. Where an engine is measured, as the result of a protest, the protest must be submitted with the appropriate fee plus £250.00 which can only

be returned if the protest is upheld. If the protest is unsuccessful then the deposit will be awarded to the person against whom the protest has been made and the protest fee will be sent to the ACU

Benevolent Fund. The Clerk of the Course shall judge as guilty anyone who refuses to present an engine for measurement. The rider will be excluded from the results of the event and will be fined. If engines are presented for measurement, but this cannot be carried out at the event, the engines must be sealed for later measurement. If seals are damaged or removed the rider will be excluded from the results and fined.

ESR.14 HELMETS/CAMERAS

Motorcycle helmets bearing a valid ACU gold or silver stamp and correctly fitted, must be worn by all competitors, both riders and Sidecar passengers, at all times, whilst riding a motorcycle or quad. Officials must wear a correctly fitted helmet, at all times, whilst riding a motorcycle and it is recommended that they wear a helmet whilst riding a quad. Unless the helmet is manufactured with the camera as an intrinsic part, helmet cameras (including the helmet camera brackets) and cameras attached to the body are prohibited. Cameras attached to the machine are permitted.

ESR.15 CLOTHING

Suitable strong clothing must cover legs, arms and body. Knee length boots and gloves in leather or other approved material must be worn. Helmets and clothing must be presented to machine examiners at the same time as the machine. It is not advised that bulky hard objects such as tools etc. are carried in pockets or on the person.

ESR.16 JEWELLERY

Competitors are advised not to wear hand, face or body jewellery, which could prove hazardous in the event of an accident. The mouth should be kept clear of anything likely to cause a blockage of the airway in the event of an accident, e.g. chewing gum. This includes false dentures.

ESR.17 TRANSpONDERS

Where Transponders or other electronic timing devices are required to be carried by the competitor to record times, the onus on ensuring the device is correctly fitted and maintained throughout the competition rests with the rider.

If competitors are required to supply their own transponders, details of this requirement must be stated in the Supplementary Regulations.

If an Organiser intends to hire or loan transponders or timing devices to individual competitors, details of any deposit scheme required must be clearly stated in the Supplementary Regulations.

ESR.18 SAFETY pRECAUTIONS

There shall be a Safety Officer appointed who will be responsible for arranging and coordinating both Medical and Fire Protection services. For events held on Forestry land the Safety Officer shall hold a current ACU Safety Officer's licence.

Marshals or First Aid officers should only travel in the same direction as competitors or use alternative routes, unless under the most severe circumstances, while carrying out their duties.

Warning Notices

The Clerk of the Course will be responsible for the siting of approved WARNING NOTICES (see Safety Precautions Section of Handbook for further details) at entry to event site, paddock and appropriate places around the course such as Tests and spectator points.

Spectator safety

Due to the nature of motorcycle events in Forests and all terrain-type courses (i.e. generally long distance endurance events with low average speeds, primarily using rough tracks), not many spectators are attracted.

However, as such events are often run on areas considered to be public places, this presents a risk in

that members of the public, whether invited or uninvited, may attend or unintentionally come across the event.

Therefore, the planning of the route must demonstrate that due consideration has been given to spectator and third party safety, considering such factors as:

- a) Points of access to the course, authorised and unauthorised
- b) Popular viewing areas.
- c) Other areas as identified in the Risk Assessment

The risk assessment process for the event should assess the suitability of area for spectators, considering the need to avoid spectators standing on the outside of a corner or within landing distance of a jump, where there is little protection provided. Any identified possible high risk areas should be designated as prohibited no-go areas. These must be marked in accordance with the ACU signage and where necessary, additional taping used to define these areas. It is recommended that red or red and white hazard tape be used.

ESR.19 MEDICAL SERVICES

The Clerk of the Course is responsible for siting the Medical services provided at the event. Considerations should be given to the access to all areas of the course and to the entrance(s) exit(s) of the event. It is advised that Medical services are liaised with and consulted in advance. The Clerk of the Course must ensure sufficient medical services for the type of event remain in place until the event has finished.

For National and International Events a Medical Officer or Paramedic must be in attendance. For all events a Medical Officer (MO) or a Paramedic (PM) or voluntary or private ambulance providers must be in attendance during the event.

In addition, qualified First Aid personnel must be in attendance with full First Aid equipment including a stretcher. A minimum of one ambulance and one other suitably identified vehicle which must also be equipped with and able to carry a stretcher must be available and one of these vehicles must always remain available at the event. NB An ambulance, by law, must be registered with the DVLA and be CQC-registered in order to transport a casualty to hospital. An ambulance must have an appropriately qualified driver to transport a casualty under blue lights. It is recommended that each special test should have at least one ambulance present and the start and finish area should have one ambulance or medical point. If for any reason the level of medical cover is diminished below acceptable levels (for example it has to leave the event or is not likely to be able to treat a casualty), the Clerk of the Course should suspend the competition at the earliest practical opportunity. This may be anywhere on the course.

Competitors should be marshalled in the safest practical way back to the start/finish area.

The decision to restart or cancel the event rests upon the Clerk of the Course, dependent upon on the revised level of medical cover.

The Clerk of the Course must also refer to the "Medical Services & Definition" section of this Handbook.

Concussion/suspected concussion

If a competitor is involved in an incident which results in him being diagnosed by the Medical Officer/Paramedic as suffering from concussion or suspected concussion, the rider is not permitted to participate any further in that event.

Organisers are to notify ACU Head Office as soon as possible of any concussion or suspected concussion injuries and then will subsequently:

- a) Place the rider on the ACU Stop List
- b) Inform Organisers of forthcoming events that the Rider has suffered a concussion or suspected concussion injury and is therefore placed on the ACU Stop List
- c) Inform the Rider that he needs to see a Doctor and obtain a letter/doctor's certificate which confirms he is fit to resume competitive racing/participate in a practice/test session.

The recovery time for anyone diagnosed with concussion/suspected concussion is as follows:

- a) Over 20 years: Excluded immediately and suspended for a period of nine days.
 - b) 16–19 years: Excluded immediately and suspended for a period of twelve days.
 - c) 15 and under: Excluded immediately and suspended for a period of twenty three days.
- The rider is not permitted to ride during the obligatory suspended periods outlined above and then only once he is in possession of a doctor's certificate/letter after the suspended period has expired.

If a competitor has been injured on a Saturday and is suffering from concussion/suspected concussion, and the Organiser is aware that the rider was intending to ride or is scheduled to ride somewhere else the next day, the Organiser will inform the Organiser of the event being held the next day so they are aware of the rider's injuries and as such he is prevented from participating in that event.

ESR.20 TEAR OFFS

The use of "Tear Off" lenses on goggles is prohibited. The use of "Roll Off" goggle systems where the transparent plastic film is retained within the device and not discarded is allowed.

ESR.21 FIRE PROTECTION

At each refuelling point and other areas of fire risk, a 'Fire Point' must be sited. The 'Fire Point' will be identified by a red sign upon which the words 'Fire Point' shall be printed in black letters or white letters. The sign shall be in an area that must be kept unobstructed at all times. Sufficient dry powder fire extinguishers shall be placed directly at the foot of the sign. A "No Smoking" sign should always be used at refuelling points.

ESR.22 PETROL TAPS

Riders must check that their petrol taps are turned off before leaving their motorcycles in the Parc Ferme.

ESR.23

ESR.24 RESTRICTED SPEED (BLUE TAPE) AREAS

These areas MUST be established on the approach to the Time Control Clock and refuelling points and will be identified by BLUE TAPE defining the route. Within BLUE TAPE area riders MUST NOT exceed walking pace, under penalty of disqualification. The Clerk of the Course may also establish BLUE TAPE areas at other parts of the route if required. The BLUE TAPE area must be clearly identified by signs or Blue Tape. In addition, a board, at least 600mm × 300mm with diagonal blue stripes on a white background will indicate the start of a BLUE TAPE Area. A similar board with a Black Cross will indicate the end of a BLUE TAPE Area.

ESR.25 CLOSED CONTROL (PARC FERME)

After administration and examination the machine may be placed into a parc ferme. Where possible it should be properly fenced, otherwise its limits should be properly marked and controlled by officials to ensure that only authorised persons may enter. Access to the parc ferme is only allowed to the Stewards of the Meeting, Clerk of Course and officials controlling the area. Riders and passengers may only enter when parking or collecting their machines and must not interfere with other machines. If any work or adjustments are made to a machine whilst in the Parc Ferme the rider is liable to penalty up to and including disqualification. Machines must either have a fitted or temporary stand and must not be covered in any way whilst in the Parc Ferme. In multi-day events, where organisers do not intend to place machines in the Parc Ferme overnight but return them to riders, this must be clearly stated in the Supplementary Regulations.

ESR.26 START COMPOUND

A Start Compound is optional for organisers of events without a Parc Ferme. Only riders may enter

the start compound and regulations governing Parc Fermes apply. In multiday events, organisers should check all machines entering the compound are the same machines presented to machine examining. If organisers intend to use a Start Compound, then it must be clearly stated in the Supplementary Regulations.

ESR.27 START

Riders will be informed prior to the event of both their starting time and riding numbers.

The Start order and method of start will be stated in the Supplementary Regulations with maximum number of drivers starting per minute being: - Solo - 4. Sidecar - 2.

NB Where an MSA permit is issued, the maximum number of starters must be 2 per minute.

(a) Starting Procedure for events with a Parc Ferme.

ESR 25 applies for entry.

Each rider will be allowed to enter the Parc Ferme 5 minutes before his starting time and push their machine to the exit.

(b) Starting Procedure without Parc Ferme but with Start Compound.

Competitors are required to place their machines in the start compound 15 minutes prior to their start time each day. Failure to do so will incur a 20 second penalty.

(c) Starting Procedure without Parc Ferme or Start Compound.

Procedure must be clearly stated in the Supplementary Regulations.

Starting Regulations (all procedures). Machines must not be started in areas considered as Parc Ferme. A starting signal will be given at the exact time the rider is due to start. Within one minute after the signal is given the Competitor must have started their engine, by kick-start or other fitted starting device only and ride to the 20m line under engine power. Failure to do so will incur a penalty, he may then start the machine by other means.

If a rider is not on the start line at this due time he will not be penalised so long as he completes the correct procedure and crosses the 20m line within one minute of his due start time.

Riders arriving more than one minute late at the start line will be penalised by 60 seconds per minute late. They will be given the next minute as the new start time and must complete the correct start procedure.

ESR.28 RESTART

In a multiple day event, a rider who fails to be classified as a finisher or who fails to come to the start line on any day, may restart the following day under the following conditions:

- 1) Within one hour of the scheduled finish time of the last rider for that day the rider must inform the Secretary of the Meeting of the intention to restart the following day.
- 2) Thirty minutes before the start time of the first rider the next day, the rider must present the machine at the start for re-examination. It must be the same machine on which the rider started the event, in respect of frame and hubs.
- 3) The machine must then be placed in the Parc Ferme or provided the rider satisfies the Organisers on the above conditions he will be allowed to start the day and be eligible for Championship points, if applicable.

ESR.29 COURSE

The course shall consist of mainly rough track and cross country going and must be clearly marked with route markers or direction arrows. Please note the general course may be open to other users and must not be treated as a one-way route. Forest roads and tracks are NOT closed to other users and traffic may be travelling in the opposite direction.

Route marking must be positioned and angled to clearly indicate the intended direction of route. In determining the distance between the markers, organisers should give due consideration to likely conditions i.e. weather, dust etc.

The Clerk of the Course must ensure that due consideration is given to the age and abilities of the

riders when planning and marking the course and that suitable marking is displayed to guide and restrict any spectators/members of the Public who may attend.

Where a gate of arrows is constructed, riders must pass between them.

Where the Clerk of the Course requires riders to pass through a specific area, perhaps for reasons of security or to prevent environmental/land damage, this area should be marked with tape on either side OR can be marked with arrows on each side of this area. The arrows must point inward towards the direction the rider must take.

Where such areas are specifically marked, the riders must pass through the tapes or arrows and any rider not doing so is liable to a penalty up to and including disqualification.

Where such areas are specifically marked, a clearly identified Marshal should be present. If possible, these Marshal(s) should ensure that the markers or tape remain in place and that riders take the intended direction.

Recommended Marking of Junctions.

- One arrow approximately 50 metres in advance of the junction giving due consideration to likely conditions, fog, dust, etc.
- Two arrows at the junction.
- One arrow after the junction to indicate correct route.

Wrong Direction Markers. Where appropriate, wrong direction signs of black cross on suitable background or 'no entry' sign should be displayed.

Diversions Routes. All points where separate routes are to be followed by different classes must be clearly indicated as follows:

- In advance of diversion, a warning sign.
- At the point of the diversion, a further sign indicating the routes to be taken in each class.
- After the diversion, a further sign that indicates which route is being followed.

The size and positioning of the signs must be such that the information is clearly communicated. **Caution Boards.** To warn drivers of severe hazard points on the route crossed arrows or an exclamation sign should be used.

Removal of Course Markers – Multiple Day Events. It is recommended that where the routes for subsequent days follows the same route as the previous day, at all points where the route diverts, the previous day's arrows should be removed, and if possible wrong direction arrows displayed.

Warning Signs for the Public. Examples of warning signs for the public are to be found elsewhere in this Handbook. Please refer to Safety Precautions section at rear of this Handbook.

Mileage. Organisers should ensure that the lap length exceeds 10 miles per lap. Recommended overall scheduled time per rider should be within daylight hours. Mileage quoted by the organizer must be taken as correct and the average speed set between any time check must not exceed 30mph. (SRs for 'short course' enduros shown separately.) On Forestry Commission land the overall average speed must not exceed 25mph.

Impassable Route. If the Clerk of the Course decides that any part of the route becomes impassable during the event, he may delete that section and adjust the time accordingly.

Course Cutting. Any rider reported to the Clerk of the Course for course cutting or not following the intended route is liable to penalty up to and including disqualification.

ESR.30 TIME AND ROUTE CHECKS

The timing of events, either wholly or in part, may be carried out either by a licensed Timekeeper or by any other competent person appointed by the Clerk of the Course. These officials, if not registered Timekeepers, shall be classified as Enduro Time Marshals. Apart from the correction of errors which may emerge on investigation, the times, speeds and classification of an event shall be taken as fact and no appeals shall be accepted as to their accuracy.

Time cards and route cards for the first day's run MUST be issued at the preliminary examination. For a multiday event, time cards MUST be issued after the preceding day has been completed. Riders will be responsible for getting their cards stamped/marked at all time and route checks. Failure to do so, or

intent to deceive the organisers by altering or obliterating these cards, or using another rider's card is liable to penalty up to and including disqualification.

Time schedules will show the time that a rider is allowed between time checks.

- Loss of time card/route card will incur a penalty.
 - A rider who misses a time/route check or arrives from the wrong direction is liable to penalty up to and including disqualification.
 - The onus rests with the riders to present a time card to the Time Check Official in a flat and legible condition.
- (a) **Indication of Time Checks** Time checks will be indicated by white flags placed on both sides of the track approximately 200m before the check and the two yellow flags placed approximately 20m before the control table.
- (b) **Procedure at Time Checks**
- After the rider has passed the yellow flags with his motorcycle he must immediately present his time card. The arrival time at a time check is the time the rider passes the yellow flags. A rider is deemed to have entered the check when the front tyre of their machine has crossed an imaginary line between the two yellow flags.
 - Riders stopping between the yellow flags and the time check will be given the time indicated on the clock when they passed the yellow flags.
 - A rider may pass the final time check of the day early, without penalty.
 - At each time check the official is obliged to mark each riders time card with the arrival time and keep a backup checklist showing all riders arrival times.
 - The area from the yellow flags to a point approximately two metres beyond the control table is considered "Parc Ferme" with regard to access, servicing and assistance.
- (c) **Calculation of Time Check Penalties.** Each section between time checks constitutes a test in itself. Riders who exceed the time permitted between one time check and the next, will be penalised 60 points per minute late arrival according to the time registered by the clock when they clock in $ARRIVAL\ TIME = STARTING\ TIME\ FOR\ NEXT\ SECTION$.
- (d) **Claims for special time allowance.** If a rider can prove to the organisers that they were delayed by abnormal circumstances beyond their control, such as a delay occasioned by stopping to render first aid in the case of a serious accident, an allowance may be given. The competitor must complete the entire route for this to be considered. Alleged balking caused by another rider cannot be considered abnormal circumstances.
- (e) **Time Limit.** Unless specified in the Championship or Supplementary Regulations a rider who arrives at a time check more than (X) minutes after their original starting time for a day's run, plus the time allowed for travel between each time check passed and any time allowance claimed for Noise Testing is automatically disqualified.
- NB (X) = Solo Championship and Experts class – 30 mins. All other classes 60 mins**
- (f) **Route Checks.** These may or may not be marked on the route card and will be indicated by blue flags approximately 20 metres prior to the checkpoint. Competitors must stop in order to have their passage recorded as required on their time card or a card attached to their machine. Any rider whose passage is not marked may be disqualified. Route checks are designed to ensure competitors stick to the marked route and it is recommended that organizers include at least one route check per day.

ESR.31 SPECIAL TESTS

There shall be a minimum of two special tests per day for all riders apart from in exceptional circumstances of Force Majeure. The same test may be used twice. These must be accurately timed and may be of Cross Country, Motocross, Hill Climb type, or as specified in the Supplementary Regulations. It is desirable that the special tests be electronically timed with a backup system if practicable.

Special Tests may be inspected on foot but NOT by any wheeled vehicle (including mountain bike) and breach of this rule renders the competitor liable to penalty up to and including disqualification. Any rider who fails to take the intended authorised route may be penalised by the Clerk of the Course if he feels an advantage has been gained. It is recommended that for Championship class riders, there should be at least 15 minutes of test riding each day. Ideally, tests should last approximately 5 minutes. The start and finish of each test should be marked with a suitable sign and be in place prior to any competitor inspecting the test. Competitors must start each test from a standing start, from a dedicated point, which shall be indicated either by an official or physical equipment. A run off area of 20m must be marked following the finish of the test, competitors must not stop in this area. Breach of this rule renders the competitor liable to penalty up to and including disqualification.

ESR.32 PRACTISING

Practising on any part of the course is forbidden. Special Tests may be inspected on foot but NOT by any wheeled vehicle (including mountain bike) and breach of this rule renders the competitor liable to disqualification. Where another event takes place at the same venue it will not be considered to constitute unofficial practice.

ESR.33 REFUELLING

Refuelling may only be carried out at points designated by the Clerk of the Course and any rider who refuels at any other point will be disqualified.

No time allowance will be made for refuelling and this must be done during the running time. The Clerk of the Course must set Refuelling Points to the following requirements.

- Distance between refuelling points should not exceed 30 miles. (Under certain circumstances, this may be increased but MUST be approved by the T&E Committee in advance and then clearly stated in the Supplementary Regulations.)
- No refuelling point shall be on the public highway (laybys may be acceptable but MUST be approved by the T&E Committee in advance)
- Refuelling points are to be marked with GREEN FLAGS – full details of location should be available at the start.
- The Clerk of the Course must provide adequate fire fighting equipment. There should be a suitably marked FIRE-POINT and NO SMOKING signs displayed.
- Marshalls must be present throughout the event. The following apply to Refuelling Points.
- Only officials, competitors and authorized helpers to be allowed access.
- Each service crew must supply their own fire extinguisher.
- Each machine being refuelled and/or serviced must be on an environment mat.
- The engine must be stopped when refuelling.
- Smoking or the use of mobile phones in refuelling points is forbidden.

ESR.34 ENVIRONMENTAL MATS

Where any refuelling or servicing of a motorcycle is being undertaken, riders must provide and use an environmental mat to protect the ground. These mats are to be removed by the competitors after use. The minimum dimensions of the mat will be at least equal to the length of the motorcycle and the width of the handlebars.

ESR.35 OUTSIDE ASSISTANCE

Outside assistance is forbidden liable to penalty up to and including disqualification and occurs when:

- A rider is accompanied on the course.
- Any person other than the rider, or an official performing his duties, comes into contact with the machine other than at a designated service area.

At Designated Service Areas specified by the Clerk of the Course, support Crews may work on the riders' machines with the exception of changing tyres at the final check of the day. A tyre change must be carried out solely by the rider once a wheel is removed.

On all other parts of the course riders **only** may work on the machines with spares and tools as carried on the machine.

ESR.36 pENALTIES

REFER TO APPENDIX B AT THE END OF THE TIME CARD ENDURO STANDING REGULATIONS IN THIS HANDBOOK

ESR.37 TIME pENALTIES

For every minute late at the start line – 60 seconds.

For each full minute late or early at time check – 60 seconds. For each second on a special test – 1 second.

For each part second on a special test where electronically timed – 1/100 sec late = 1/100 second.

ESR.38 RESULTS

For each event a set of Results must be produced which display the event date and Permit number. The method to be used for the publication of the results must be shown in the Supplementary Regulations or the Championship Regulations. Acceptable formats are by post, email or website but in addition for every event a set of provisional results must be sent (either by post or by email) to the Permit issuing authority. These must clearly show the date and time of publication.

If these provisional results are amended then a copy of the revised set, clearly marked "Amended (date)" must be sent by post or email to the Permit Issuing Authority and any rider affected by the amendment.

ESR.39 AWARDS

Full details of awards will be stated in the Supplementary Regulations.

ESR.40 pROTESTS

See Appendix B of this Handbook.

Where it has been previously stated in the Championship Regulations or Supplementary Regulations and the full results are displayed, signed by the Clerk of the Course (or appointed official) with the time of day, on a board within 30 minutes of the last rider finishing any protest must be submitted within 30 minutes of the time of signing.

Where results are sent by post, sent by email or published on a website any protest must be submitted within 5 days of publication.

The date of publication of results on a website or by email should be shown on the results, or confirmed by postmark if mailed and the Protest period will commence from this date.

Protest against the Capacity/power of a motorcycle must be accompanied by a deposit of £250 to cover associated costs.

The interpretation of these Standing Regulations and the Supplementary Regulations or Instructions to rider will rest entirely with the Stewards of the Meeting whose decision shall be final and binding except as provided in the National Sporting Code.

ESR.41 LEGAL ACTION

A rider who is convicted following a police prosecution for an offence committed by him whilst taking part in the competition is liable to penalty up to and including disqualification.

ESR.42

ESR.43 INSURANCE

The responsibility is on the rider to ensure that his motorcycle complies with all legal requirements. The Organisers will be required to cover Riders and Passengers against Third Party insurance for 'off- the-road' risks whilst taking part in the event and the premium for such insurance will be included in the entry fee. The ACU have arranged third party RTA Insurance as a blanket cover across the whole Membership to cover any competitor, marshal or Official signed on for an ACU permitted event which, for the duration of the permit, will allow them to use any motor vehicle in connection with the event in areas of the event where the Road Traffic Act is deemed to be applicable. The RTA cover will be provided in the same way as the ACU Public Liability and other insurance covers. That is to say when the Rider, Marshal or Official signs on at an event, the cover is automatically in place. The RTA cover comes at no extra cost to the Organiser as this cover is provided free of charge by the ACU.

ESR.44 DISCLAIMER

It is a condition of acceptance of entry that the Organiser shall not be responsible for any damage to a motorcycle or its accessories, whether by fire, accident or other causes, nor for the theft of a motorcycle or its accessories, during the event.

ESR.45 LIABILITY FOR DAMAGE

A rider is liable for any damage caused by himself, his passenger, or any helpers, during the event. The Clerk of the Course may act as agents for such persons to agree and pay for any damage and the riders shall on demand reimburse the Organisers any sum so paid.

ESR.46 ABANDONMENT

The Organisers with the approval of the Clerk of the Course reserve the right, subject to the approval of the Stewards of the Meeting, to cancel, postpone or abandon the competition, if circumstances should arise, which, in their opinion, render such action necessary.

ESR.47 COMPLIANCE WITH REGULATIONS

Every Rider by entering or being entered or nominated thereby acknowledges that he is bound by the National Sporting Code of the ACU and these Standing Regulations, together with any Supplementary Regulations and Final Instructions to be hereafter issued, to all of which he undertakes to submit and moreover renounces any right to have recourse to any arbitrations or tribunal not provided for in the said Rules and Regulations.

ESR.48 OFFENSIVE BEHAVIOUR

Any rider, or party with an interest in a rider's performance, who is reported to the Clerk of the Course for arguing or being offensive to an Official, may result in that rider becoming liable to penalty up to and including disqualification and/or disciplinary action.

All such incidents must be reported to the T&E Committee who may take further disciplinary action.

ESR.49 INTERPRETATION

The interpretation of these Standing Regulations and the Supplementary Regulations or instructions to Riders will rest entirely with the Stewards of the Meeting whose decision shall be final and binding except as provided in the Sporting Code.

ESR.50 FIRE EXTINGUISHERS

All competitors except for those travelling to an event on the machine on which they are competing, must have a 2kg (minimum) dry powder fire extinguisher available for immediate use. If a 'closed vehicle' is being used the extinguisher must be fitted adjacent to, or on the inside of the working

door. In the case of a shared vehicle the other competitor's extinguisher(s) should also be visible, or, the fitted extinguisher(s) must be of a proportionately larger capacity. This fire extinguisher must be available at any refuelling point.

ESR.51 POWER WASHERS

Use of power washers is prohibited unless the organisers have suitable facilities.

APPENDIX A DIAGRAM OF MACHINE

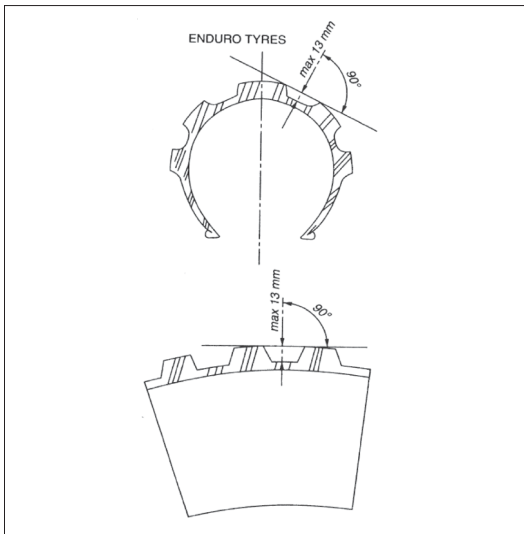
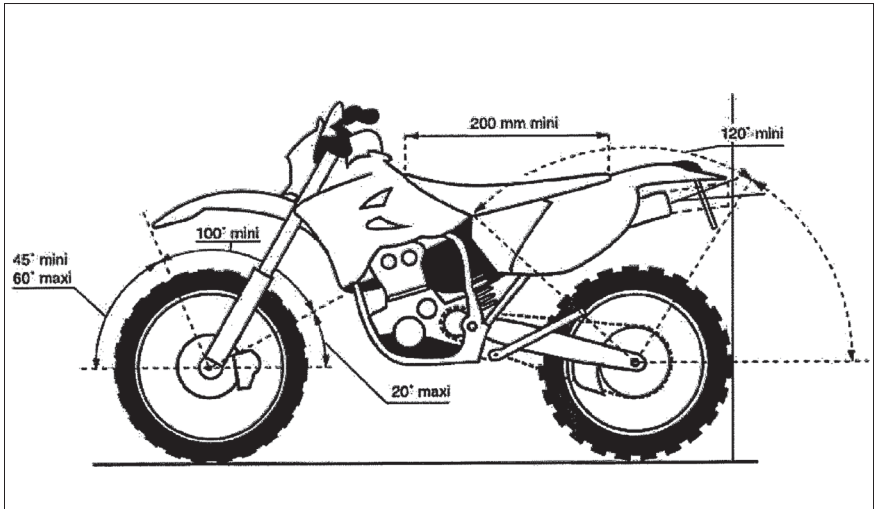

AppENDIX B PENALTIES

Up TO AND INCLUDING DISQUALIFICATION

- Using non-specified tyres.
- Smoking in the Parc Ferme or any restricted service area.
- Engine capacity other than stated to organizers.
- Exceeding walking pace in Blue tape areas.

- Changing parts which are liable for marking or presenting a machine with missing marked parts except for the silencer which may be changed as per ESR 10.
- Altering the course.
- Altering a time card.
- Practising on the course prior to the event.
- Accepting outside assistance other than allowed in Standing Regulations.
- Exceeding noise level limit.
- Being accompanied anywhere on the course.
- Change of machine during event.
- Changing tyres except at the final time check of the day, or in a multi-day event where a work area is provided.
- Course cutting, not following marked route or driving in opposite direction of route.

pENALTY pOINTS

Starting engine in parc ferme, working area or before starting signal is given	60
seconds Loss of timecard/route card	60
seconds	
Not starting engine and crossing 20m line within one minute of starting signal	20
seconds Failure to have the rider's machine in the start compound (when used) 15 minutes	15 minutes
prior to the start time	20 seconds
Entering parc ferme with engine running	60 seconds
Failure to attend machine examination when held on day prior to start	20 seconds

ALL TERRAIN (RALLY) REGULATIONS (ATR)

The National Sporting Code of the ACU and the Enduro Timecard Standing Regulations as varied by the ATR shall apply to all All Terrain Events together with the Supplementary Regulations and any Final instructions issued for individual events.

The following are articles, specifically for All Terrain events, override the Enduro Timecard Standing Regulations. All other Enduro Standing Regulations remain in force.

Description: A sporting event staged over varied terrain, predominantly Forest Roads and Tracks, and is intended to prove the skill and endurance of riders and the reliability of their machines.

The event is aimed at production Trail motorcycles of all capacities and the route shall be planned accordingly.

The route may be marked with route markers, or may require the competitor to use navigational skill or may require a combination of both.

ATR.1 ELIGIBILITY

All riders and passengers must hold a current ACU or SACU licence, and be aged 16 years or over. Any rider or passenger from another FMN MUST produce a licence issued by their FMN together with start permission and proof of personal accident Insurance.

Where the Event includes the use of public highways, then this will be stated in the Supplementary Regulations. If public highways are used then it is sole responsibility of the rider to ensure that his machine is roadworthy and that he and his machine comply with all legal requirements.

ATR.2 ENTRIES

A Motorcycle Sport Event Entry Form must be completed in every detail, and signed by relevant entrant, rider and passenger. Each completed entry form, together with the entry fee (which includes insurance premiums), shall be forwarded to the Secretary of the Meeting. Details of the name, address and telephone number of the Secretary of the Meeting (or a deputy), all entry fees, closing date for entries, conditions for return of fees, and any other special requirements, may be obtained from the event Supplementary Regulations.

All riders and passengers must register arrival at an event by signing-on at the event control office, or other designated area, not less than 30 minutes prior to commencement of said competitor's start time.

Riders and Passengers under 18 years of age (Minors): In order to conform with the Children's Act legislation, additionally, for every rider or passenger who is under 18 years of age a Parental Agreement must be signed. This is incorporated in the Annual Competition Licence Form and once completed will serve as the riders Annual Parental Agreement. If applying for a "One Event Licence" then this must include Parental Agreement. All minors will be bound by the directions of parent(s), guardian(s). Child Protection. The point of contact for Child Protection issues will be the Secretary of the Meeting unless otherwise stated in the Supplementary Regulations.

ATR.3 ACCEPtANCE OR REFUSAL OF ENTRY

Within 3 days of the official closing date, the Organiser must notify riders of the definite position with regard to their entry and whether such entry has been accepted, or is being held in abeyance, or has been refused. The closing date of entries, the conditions for return of Entry Fees and any other special requirements will be contained in the Supplementary Regulations. All Supplementary Regulations must carry the telephone number of a responsible official.

Limitations of Entries. If entries are to be limited, the maximum number and method of limitation (i.e. in order of receipt, by ballot etc.) shall be stated in the Supplementary Regulations. Events using Public Highways are limited to 180 competitors, with the exception of exempt events. See RAC Motor Vehicles (Competitions and Trials) Regulations.

Change of rider. All entries will be deemed to be in respect of the rider so named and no change of rider will be permitted except in the case of "Team Only" competitions where the Team Entry is submitted by a Team Manager. For "Team Only" competitions any change of an individual entry will be subject to the conditions of the Supplementary Regulations.

ATR.4 INSTRUCTIONS TO RIDERS

Any written instructions subsequently issued shall have the same force as these Standing Regulations and the Supplementary Regulations.

ATR.5 CLASSES

Classes will be as detailed in Supplementary Regulations for the event. Time Schedules and/or Routes may vary between classes – details will appear in the Supplementary Regulations.

ATR.6 CHANGE OF MACHINE AND/OR PASSENGER

Any change of machine within the same capacity group and/or passenger must be notified to the Secretary of the Meeting a minimum of 24hrs before the start of the Competition. Any restrictions regarding change in the capacity group of a machine may be detailed in the Supplementary Regulations.

ATR.7 MOTORCYCLES

The responsibility is on the rider to ensure that his motorcycle complies with all legal requirements including horn, speedometer. All motorcycles must be fitted with working lights.

Machine Specification: Solo class category 1 group A1.

Brakes: Each wheel must be fitted with a brake. Machines fitted with linked brakes as standard equipment are permissible.

ATR.8 TYRES

Only tyres normally available from commercial or retail sources are authorised. They shall appear on the tyre manufacturers range catalogue or tyre specification list available to the general public. They must be manufactured to comply with the European Tyre and Rim Technical Organisation (ETRTO) requirements in respect of load and speed codes and have a minimum service description of 45M. Enduro tyres must have a E Mark and/or DOT (American Department of Transportation) approval and DOT number must be moulded on the tyre wall. Enduro tyres must be to current FIM specification. The use of MX tyres is not allowed.

ATR.9 FUEL

Commercially available unleaded fuel must be used. Power boosters or octane boosters are forbidden.

ATR.10 NOISE

It is the sole responsibility of the rider to present a machine complying with all Road Traffic Act(s) requirements including exhaust sound level. Only the 2 metre max test will be used. The maximum sound limit accepted will be 112 dBA before the Start (+2 dB/A during or after the event).

(For precise method of testing, see Sound Control Regulations in this Handbook).

There may be one or more sound level tests taken during the event at any point on the route, as close as practical following a time control or refuelling area. Any rider who is required to take this spot test may, if he requires, claim a delay time allowance of TWO minutes at the next time control. Any rider who fails the sound level test will face immediate disqualification. At any time during the event, the Clerk of the Course or their appointed official is empowered to disqualify any machine they consider to be excessively noisy.

ATR.11 RIDER'S NUMBERS

Unless stated in the Supplementary Regulations riders must provide their own numbers which must be a minimum height of 100mm.

ATR.12 EXAMINATION OF MACHINES

Machines will be examined before the start to ensure compliance with the Standing Regulations and ACU Technical Specifications.

ATR.13 HELMETS

Motorcycle helmets bearing a valid ACU gold or silver stamp and correctly fitted, must be worn by all competitors, both riders and Sidecar passengers, whilst riding a motorcycle or quad. Officials must wear a correctly fitted helmet whilst riding a motorcycle and it is recommended that they wear a helmet whilst riding a quad.

Unless the helmet is manufactured with the camera as an intrinsic part, helmet cameras (including the helmet camera brackets) and cameras attached to the body are prohibited. Cameras attached to the machine are permitted.

ATR.14 CLOTHING

Suitable strong clothing must cover legs, arms and body. Knee length boots and gloves in leather or other approved material must be worn. Helmets/Clothing must be presented to machine examiners at the same time as the machine. It is not advised that bulky hard objects such as tools etc. are carried in pockets or on the person.

TEAR OFFs The use of "Tear Off" lenses on goggles is prohibited. The use of "Roll Off" goggle systems where the transparent plastic film is retained within the device and not discarded is allowed.

ATR.15 JEWELLERY

Competitors are advised not to wear hand, face or body jewellery, which could prove hazardous in the event of an accident. The mouth should be kept clear of anything likely to cause a blockage of the airway in the event of an accident, e.g. chewing gum. This includes removing false dentures.

ATR.16 TRANSpONDERS

Where Transponders or other electronic timing devices are required to be carried by the competitor to record times, the onus on ensuring the device is correctly fitted and maintained throughout the competition rests with the rider.

If competitors are required to supply their own transponders – details of this requirement must be stated in the Supplementary Regulations.

If an Organiser intends to hire or loan transponders or timing devices to individual competitors, details of any deposit scheme required must be clearly stated in the Supplementary Regulations.

ATR.17 SAFETY pRECAUTIONS

There shall be an Incident Officer appointed who will be responsible for arranging and coordinating both Medical and Fire Protection services. The Incident Officer may undertake other duties at the events. Marshals or First Aid officers should only travel in the same direction as competitors or use alternative routes, unless under the most severe circumstances, while carrying out their duties.

ATR.18 MEDICAL SERVICES

At all events qualified First Aid personnel must be in attendance with full First Aid equipment including a stretcher. A minimum of one ambulance and one other suitably identified vehicle which must also be equipped with and able to carry a stretcher must be available and one of these vehicles must always remain available at the event. NB. An ambulance, by law, must be registered with the DVLA and be CQC-registered in order to transport a casualty to hospital. An ambulance must have

- I an appropriately qualified driver to transport a casualty under blue lights. Organisers must also refer to the “Medical Services & Definition” section of this Handbook.

ATR.19 SITING OF MEDICAL SERVICES

The Clerk of the Course is responsible for siting the Medical services provided at the event. Considerations should be given to the access to all areas of the course and to the entrance(s) exit(s) of the event. It is advised that Medical services are consulted in advance. If for any reason the level of medical cover is diminished below acceptable levels (for example it has to leave the event or is not likely to be able to treat a casualty), the Clerk of the Course should suspend the competition at the earliest practical opportunity. This may be anywhere on the course.

Competitors should be marshalled in the safest practical way back to the start/finish area.

The decision to restart or cancel the event rests upon the Clerk of the Course, dependent upon on the revised level of medical cover.

ATR.20 FIRE PROTECTION

At each refuelling point and other areas of fire risk, a ‘Fire Point’ must be sited. The ‘Fire Point’ will be identified by a red sign upon which the words ‘Fire Point’ shall be printed in black letters. The sign

shall be in an area that must be kept unobstructed at all times. Sufficient dry powder fire extinguishers shall be placed directly at the foot of the sign.

ATR.21 PETROL TAPS

Riders must check that their petrol taps are turned off before leaving their motorcycles in the Start Area or any other Control.

ATR.22 WARNING NOTICES

The Incident Officer will be responsible for the siting of approved WARNING NOTICES (see Safety Precautions Section of Handbook for further details) at entry to event site, paddock and appropriate places around the course such as Tests and spectator points.

ATR.23 RESTRICTED SPEED (BLUE TAPE) AREAS

These areas MUST be established on the approach to the Time Control Clock and refuelling points will be identified by BLUE TAPE defining the route. Within BLUE TAPE area riders MUST NOT exceed walking pace, under penalty of disqualification. The Incident Officer/Clerk of the Course may also establish BLUE TAPE areas at other parts of the route if required. The BLUE TAPE area must be clearly identified by signs. In addition, a board, at least 600mm × 300mm with diagonal blue stripes on a white background will indicate the start of the BLUE TAPE Area. A similar board with a Black Cross will indicate the end of the BLUE TAPE Area.

ATR.24 MACHINE PARK

After preliminary examination the machine may be placed into a Start Compound or Parc-Ferme as indicated in the Supplementary Regulations.

A Starting Compound is a taped area where the bikes must be left after preliminary examination until the rider is called to start.

A parc-ferme should be properly fenced; otherwise its limits should be properly marked and controlled by officials to ensure that only authorised persons may enter. Access to the parc ferme is only allowed to the Stewards of the Meeting, Clerk of Course and officials controlling the area. Riders and passengers may only enter when parking or collecting their machines and must not interfere with other machines. If any work or adjustments are made to a machine whilst in the Parc Ferme the rider will be disqualified.

ATR.25 WORKING AREA/MACHINE MAINTENANCE

In the case of a Start Compound (ATR.24) then work may be carried out in this area. In the case of a Parc-Ferme (Atr.24) then details of the Working Area will be detailed in the Supplementary Regulations.

ATR.26 START

Riders will be informed prior to the event of both their starting time and riding numbers.

Start Order. Method of starting order will be stated in the Supplementary Regulations with maximum number of drivers starting per minute being 4.

Any rider starting late will not be penalised however for future Time Controls it will be assumed that he started on his allocated Start Time.

ATR.27 RESTART

In an event of more than one day, a rider who fails to be classified as a finisher or who fails to come to the start line on any day, may be allowed to start the following day subject to the approval of the Organiser. If approval is given his machine will be subject to full Machine Examination.

ATR.28 COURSE

The route may be marked with route markers, or may require the competitor to use navigational skill or may require a combination of both.

The course shall consist of Tracks and Trails including forest roads. Public Highway may also be used and if so, this must be stated in the Supplementary Regulations.

The events will consist of a number of "Liaison Stages" or "legs".

These liaison stages will form the majority of the event, and may incorporate surfaced roads, cross country tracks or the public highway.

Where the Supplementary Regulations state that the event includes the use of Public Highways, then the rider must ensure that he and his machine comply with all legal requirements.

The Clerk of Course must ensure that the route is correctly and sufficiently identified.

Numbered or Lettered boards should be displayed at regular intervals along the route; e.g each mile, so that Competitors and Marshals are able to determine at which sector of the course they are at, if emergency assistance is required.

Where route marking is used must be positioned and angled so as to clearly indicate the intended direction of route. In determining the distance between the markers, organisers should give due consideration to likely conditions i.e. weather, dust etc.

The Organiser/Clerk of the Course must ensure that due consideration is given to the age and abilities of the riders when planning and marking the course and that suitable marking is displayed to guide and restrict any spectators/members of the Public who may attend.

Where a gate of arrows is constructed, riders must pass between them.

Where the organiser requires riders to pass through a specific area, perhaps for reasons of security or to prevent environmental/land damage, this area should be marked with tape on either side OR can be marked with arrows on each side of this area. The arrows must point inward towards the direction the rider must take.

Where such areas are specifically marked, the riders must pass through the tapes or arrows and any rider not doing so will be penalised.

Where such areas are specifically marked, a clearly identified Marshal shall always be present. The Marshal/Marshals shall ensure that the markers or tape remain in place and also that riders take the intended direction.

Recommended Marking of Junctions: One arrow approximately 50 metres in advance of the junction giving due consideration to likely conditions, fog, dust, etc.

Two arrows at the junction.

One arrow after the junction to indicate correct route.

Wrong Direction Markers. Where appropriate, wrong direction signs of black cross on suitable background or 'no entry' sign should be displayed.

Diversionary Routes. All points where separate routes are to be followed by different classes must be clearly indicated as follows:

- a) In advance of diversion, a warning sign.
- b) At the point of the diversion, a further sign indicating the routes to be taken in each class.
- c) After the diversion, a further sign that indicates which route is being followed.

The size and positioning of the signs must be such that the information is clearly communicated. **Caution Boards.** To warn drivers of severe hazard points on the route crossed arrows or an exclamation sign should be used.

Removal of Course Markers – 2 Day Events. It is recommended that where the route for day 2 follows the same route as day 1 at all points where the route diverts, day 1 arrows should be removed, and if possible wrong direction arrows displayed.

Warning Signs for the Public. Examples of warning signs for the public are to be found elsewhere in this Handbook. Please refer to Safety Precautions section at rear of this Handbook.

Impassable Route. If the Clerk of the Course decides that any part of the route becomes impassable during the event, he may delete that section and adjust the time accordingly.

Course Cutting. Any rider reported to the Clerk of the Course for course cutting or not following the intended route may be subject to disqualification.

ATR.29 TIME CONTROL AND ROUTE CHECKS

For organisational reasons a Time limit may be applied and details shall be stated in the Supplementary regulations.

Any Time limit must be calculated so that the average speed of the rider does not exceed 25mph.

A time control will be indicated by white flags placed on both sides of the track 200m before the check and the two yellow flags placed approximately 20m before the control table. These flags will be placed so that they are at all times clearly visible to the riders. Official time should be visible to the rider from the yellow flags. Riders must pass between the yellow flags.

There may be one or more Route Checks where the rider may be required to stop to have their passage marked.

ATR.30 TIMED SECTION

Timed Section/Special Stages: The inclusion of Timed Sections or Special Stages is optional. If these are included they will be used to decide finishing order and details must be included in the Supplementary Regulations of how they will be timed.

Where a Timed Section/Special Stage is included in an event it must not be timed on the first lap which will be a "sighting lap".

ATR.31 PRACTISING

Practising on any part of the course is forbidden.

ATR.32 REFUELLING

Refuelling may only be carried out at points designated by the organisers and any rider who refuels at any other point will be disqualified. No time allowance will be made for refuelling and this must be done during the running time or the ten minutes prior to the start.

The organizer must set Refuelling Points to the following requirements.

- No refuelling point shall be on the public highway (remote lay bys are acceptable)
- Refuelling points to be marked with GREEN FLAGS – full details of location to be available at the start. In two day events refuelling may be allowed in the official working area.
- The Organisers must provide adequate fire fighting equipment. There should be a suitably marked FIRE-POINT and also NO SMOKING signs displayed.

- Marshalls must be present throughout the event.

The following apply to refuelling points.

- Only officials, competitors and authorized helpers to be allowed.
- Each service crew must supply their own fire extinguisher.
- Each machine being refuelled must be on an environment mat.
- The engine must be stopped when refuelling.
- Smoking or the use of mobile phones in refuelling points is forbidden.

ATR.33 ENVIRONMENTAL MATS

Where refuelling or servicing of a motorcycle is being undertaken, riders must provide and use an environmental mat to protect the ground. These mats are to be removed by the competitors after use. The minimum dimensions of the mat will be at least equal to the length of the motorcycle and the width of the handlebars.

ATR.34 pENALTIES

Any rider arriving at a Time Control after their scheduled time will be classed as retired.

DISQUALIFICATION

- Using non specified tyres.
- Engine capacity other than stated to organizers.
- Exceeding walking pace in Blue tape areas.
- Altering course.
- Practising on the course prior to the event.
- Accepting outside assistance other than allowed in Standing Regulations.
- Exceeding noise level limit.
- Being accompanied anywhere on the course.
- Change of machine during the day.
- Changing tyres except at the final time control of the day.

Course cutting, not following marked route or driving in opposite direction of route, will result in disqualification or in exceptional circumstances the Clerk of the Course may impose a points penalty.

TIMED SECTION

Timed to 1 second 1 sec = 1pt.
Electronically 1/100 sec =
1/100 pt

ATR.35 AWARDS

Full details of awards will be stated in the Supplementary Regulations.

ATR.36 LEGAL ACTION

A rider who is convicted following a police prosecution for an offence committed by him whilst taking part in the competition may be liable to disqualification.

ATR.37 WARNING TO THE pUBLIC

The Organisers must display Warning Notices at the start of the event, the Timed Section and at any other point of the course where the public is likely to congregate.

ATR.38 INSURANCE

The Organisers will be required to cover Riders and Passengers against Personal Accident risks and third Party insurance for 'off-the-road' risks whilst taking part in the event and the premium for such insurance will be included in the entry fee. (Note: Those events organised under an ACU Basic Permit will NOT include Personal Accident cover for competitors, in this regard competitors must seek their own Personal Accident cover). The ACU have arranged third party RTA Insurance as a blanket cover across the whole Membership to cover any competitor, marshal or Official signed on for an ACU

permitted event which will allow them to use any motor vehicle in connection with the event in areas of the event where the Road Traffic Act is deemed to be applicable. The RTA cover will be provided in the same way as the ACU Public Liability and other insurance covers. That is to say when the Rider, Marshal or Official signs on at an event, the cover is automatically in place. The RTA cover comes at no extra cost to the Organiser as this cover is provided free of charge by the ACU.

ATR.39 DISCLAIMER

It is a condition of acceptance of entry that the Organiser shall not be responsible for any damage to a motorcycle or its accessories, whether by fire, accident or other causes, nor for the theft of a motorcycle or its accessories, during the event.

ATR.40 LIABILITY FOR DAMAGE

A rider is liable for any damage caused by himself, his passenger, or any helpers, during the event. The Organisers may act as agents for such persons to agree and pay for any damage and the riders shall on demand reimburse the Organisers any sum so paid.

ATR. 41 ABANDONMENT

The Organisers reserve the right, subject to the approval of the Stewards of the Meeting, to cancel, postpone or abandon the competition, if circumstances should arise, which, in their opinion, render such action necessary.

ATR.42 COMPLIANCE WITH REGULATIONS

Every Entrant and Rider by entering or being entered or nominated thereby acknowledges that he is bound by the National Sporting Code of the ACU and these Standing Regulations, together with any Supplementary Regulations and Final Instructions to be hereafter issued, to all of which he undertakes to submit and moreover renounces any right to have recourse to any arbitrations or tribunal not provided for in the said Rules and Regulations.

ATR. 43 INTERPRETATION

The interpretation of these Standing Regulations and the Supplementary Regulations or instructions to Riders will rest entirely with the Stewards of the Meeting whose decision shall be final and binding except as provided in the Sporting Code.

ATR. 44 FIRE EXTINGUISHERS

All competitors with the exception of those travelling to an event on the machine on which they are competing, must have a 2kg (minimum) dry powder fire extinguisher available for immediate use. If a 'closed vehicle' is being used the extinguisher must be fitted adjacent to, or on the inside of the working door. In the case of a shared vehicle the other competitors extinguisher(s) should also be visible, or, the fitted extinguisher(s) must be of a proportionately larger capacity. This fire extinguisher must be available at any refuelling point.

ATR.45 pOWER WASHERS

Use of power washers is prohibited unless the organisers have suitable facilities which comply with the ACU Environmental Code.

SHORT COURSE TIME CARD ENDURO STANDING REGULATIONS

The National Sporting code of the ACU and the Timecard Enduro Standing regulations as varied by the Short Course Enduro Standing regulations listed below shall apply to all Short Course Enduro events together with the Supplementary Regulations and any Final Instructions issued for individual events.

The following are articles specifically for Short Course time Card Enduro items which override the Standing Enduro regulations. All other Enduro Standing Regulations remain in force Definition Multi lap short course event.

1. ELIGIBILITY

All the riders and passengers must hold a current ACU or SACU licence and be a minimum age of 16 years. Any rider or passenger from another FMN MUST produce a licence issued by their FMN together with start permission and proof of personal accident Insurance. A Youth rider may compete as an Adult in these events but must be a minimum of 15 years of age and is restricted to a maximum machine capacity of 250cc. NB A rider who chooses to compete as an Adult cannot also compete as a Youth at any time in the same event.

2. ENTRIES

The ratio of competitors to course will be 45 riders per mile of course e.g.180 riders must have 4 mile lap distance etc. Sidecar: Half these figures. This recommended number may be changed by the authority granting the permit. *When a youth class is incorporated within an adult event or as a separate event the ratio of competitors to course shall remain as defined in the Adult event*

3. START

The maximum number of starters per minute may be 4 Solos This recommended number may be changed by the authority granting the permit.

4. COURSE

Should be Enduro style of a minimum length of 2 miles. Overall time allowance should be 3 hours minimum, 5 hours maximum. Details must appear in Supplementary Regulations.

5. TIME AND ROUTE CHECKS

Time checks will be at Start/Finish area which may also be a route/lap scoring check. There should be adequate route checks on the course

6. SPECIAL TESTS

May consist of a whole lap or as detailed in the Supplementary Regulations. However the total length of Special tests must not consist of more than 20% of the total length of the course.

7. MOTORCYCLES

(As per ESR 7) but with possible exception of lights, horns, speedometers if the course does not require machine to be legal for the Highway but requirements must appear in the Supplementary Regulations.

Youth riders may be included in Short Course Enduros either as part of a separate event or a separate class run in conjunction with the main event, provided that the following points are closely observed:

8. AGE OF RIDERS

Youth riders must be a minimum age of 15 years to participate in a Short Course Enduro and are restricted to machines of a maximum capacity of 250cc.

9. YOUTH STARTING ORDER

Where a Youth class is included as part of an Adult event, Youth riders must be started as a separate group behind the Adults.

10. PHYSICAL ELIGIBILITY/PROFICIENCY ASSESSMENT

All riders should be able to sit astride their machines and with one foot firmly on the ground must be able to control the gear lever or the foot brake with the other foot. They should also be able to lift the bike up from a horizontal position on the ground to an upright position.

11. RIDERS (MINORS)

In order to conform with the Children's Act legislation, additionally, for every rider or passenger who is under 18 years of age a Parental Agreement Form must be signed by parent/s or guardians. All minors will be bound by the directions of parent/s or guardian/s.

HARE AND HOUNDS/CROSS COUNTRY STANDING REGULATIONS

The National Sporting code of the ACU and the Timecard Enduro Standing regulations as varied by the Hare & Hounds/Cross Country Standing regulations listed below shall apply to all Hare & Hounds/Cross Country Events events together with the Supplementary Regulations and any Final Instructions issued for individual events.

The following are articles specifically for Hare & Hounds/Cross Country items which override the Standing Enduro regulations. All other Enduro Standing Regulations remain in force

DEFINITION

Hare and Hounds/Cross Country events are controlled Group Start events which are a test of endurance and reliability. Competitors will be required to complete a number of laps within a time set by the organisers The duration of events will be stated in the Supplementary Regulations.

1. ELIGIBILITY

Adult Eligibility: All the riders and passengers must hold a current ACU or SACU licence and be a minimum age of 16 years. Any rider or passenger from another FMN MUST produce a licence issued by their FMN together with start permission and proof of personal accident Insurance. A Youth rider may compete as an Adult in these events but must be a minimum of 15 years of age and is restricted to a maximum machine capacity of 250cc.

NB A rider who chooses to compete as an Adult cannot also compete as a Youth at any time in the same event.

Youth Eligibility: All the riders must hold a current ACU or SACU licence and be a minimum age of 12 years and a maximum of 16 years. However, a rider over 15yrs of age may if they so wish compete as an Adult on a machine of a maximum capacity of 250cc.

NB. A rider who chooses to compete as an Adult cannot also compete as a Youth at any time in the same event.

NB JUNIOR SUPPORT EVENTS

An additional separate Junior Support event may be run in conjunction with any Hare & Hounds/X Country events catering for 8-12 yr olds on a maximum of 85cc machine. Each rider must be visible over the entire course to the Clerk of the Course or clearly identified static marshals and travelling marshals (provided they are present in addition to static marshals). Machine Examiners should ensure that all machines in these Support events are fitted with an ignition cut-out which disables the machine when the driver dismounts.

2. CLASSES

The Supplementary Regulations may specify that capacity classes allowed in Enduro Regulations ESR

1.6 or classes determined by rider grading must start in the same group.

3. YOUTH CLASSES

The Youth class must be run as a separate session from any Adult classes at the same event and must not be combined with any Adult classes at the same event.

Youth capacity/Age/ability classes may be allowed but must be stated in the Supplementary regulations.

4. MOTORCYCLES

Subject to the Supplementary Regulations any solo machine which complies with the Motocross, Trials, Enduro Specifications as per the current ACU Handbook, may be allowed.

5. CAPACITY FOR YOUTH MACHINES

Riders aged 14 to 16 – Machines must be a minimum of 80cc and a maximum of 150cc (regardless of two or four stroke engine) and electric bikes up to 16kw measured at the rear wheel.

Riders aged 12–14 – Machines must be a minimum of 70cc and a maximum of 85cc (regardless of two or four stroke engine) and electric bikes up to 12kw measured at the rear wheel. Wheel size maximum 16 inch rear and 19 inch front.

6. PHYSICAL ELIGIBILITY/PROFICIENCY ASSESSMENT

All riders should be able to sit astride their machines and with one foot firmly on the ground must be able to control the gear lever or the foot brake with the other foot. They should also be able to lift the bike up from a horizontal position on the ground to an upright position.

7. NUMBERS

Bibs may be supplied by the organisers. If not, Riders must provide their own numbers which must be a minimum height of 100mm.

8. COURSE

Where practical, in Hare & Hounds Cross Country events, it is recommended that a guided sighting lap be offered, details of which should be included in the Supplementary Regulations.

The course shall consist of mainly rough track and cross country going and must be clearly marked with route markers/direction arrows or tape and stakes. Route marking must be positioned and angled so as to clearly indicate the intended direction of route. Courses with artificial chicanes and bends should use stakes and tape to clearly identify the course and ensure the route is followed. In determining the distance between the markers, organisers should give due consideration to likely conditions i.e. weather, dust etc.

The course must be 'off-road' and the minimum time allowed for Adult events shall be 2 hours. The organisers may split the event into 2 or more legs if desired but the minimum time for each leg must be 90 minutes. The ratio of competitors to course will be – 45 riders per mile of course, e.g. 180 riders must have 4 mile lap distance etc.

9. COURSE FOR YOUTH EVENTS

Where practical, in Hare & Hounds Cross Country events, it is recommended that a guided sighting lap be offered, details of which should be included in the Supplementary Regulations. The course must be 'off-road' and the minimum time allowed shall be 1 hour and maximum of 2 hours.

The number of laps and the time allowed must be stated in the Supplementary Regulations. The ratio of competitors to course will be – 30 riders per mile of course, e.g. 120 riders must have 4 mile lap distance etc.

The course must be a maximum of 5 miles and organisers should ensure that there should be no part of the course where a rider may fall and remain unseen by following riders or marshals. Consideration should be given to the positioning of marshals and officials to ensure this. Additional clearly identified travelling marshals can also be used to help achieve this. The course shall consist of mainly rough

track and cross country going and must be clearly marked with route markers/direction arrows or tape and stakes.

Route marking must be positioned and angled so as to clearly indicate the intended direction of route. Courses with artificial chicanes and bends should use stacks and tape to clearly indentify the course and ensure the route is followed. In determining the distance between the markers, organisers should give due consideration to likely conditions i.e. weather, dust etc.

The Organiser/Clerk of the Course must ensure that due consideration is given to the age and abilities of the riders when planning and marking the course and that suitable marking is displayed to guide and restrict any spectators/members of the Public who may attend.

Where a gate of arrows is constructed, riders must pass between them.

Where the organiser requires riders to pass through a specific area, perhaps for reasons of security or to prevent environmental/land damage, this area should be marked with tape on either side OR can be marked with arrows on each side of this area. The arrows must point inward towards the direction the rider must take.

Where such areas are specifically marked, the riders must pass through the tapes or arrows and any rider not doing so will be penalised.

Where such areas are specifically marked, a clearly identified Marshal shall always be present.

The Marshal/Marshals shall ensure that the markers or tape remain in place and also that riders take the intended direction.

Special Regulations for 2 rider teams in Hare & Hounds/Cross Country. Course and Time Session:

A team of riders must consist of a minimum of 2 riders. Each rider will be required to complete a time session. Only one rider is permitted on the course in one session with each rider completing an alternate session. The minimum time allowance per time session should be laid down in the Supplementary Regulations with the emphasis on endurance.

Any restrictions on the number of machines used by Team riders are to be stated in the Supplementary Regulations.

All machines used are to be subject to Machine Examination.

10. START

The start must be set out so that riders will start in groups which will be decided by the organisers e.g. capacity classes, ability classes etc. These groups will be defined in the Supplementary Regulations.

The number of riders in each group – which must not exceed 40 – and the start interval between groups – which must be no less than 30 SECONDS – will be decided by the organiser with due regard to course layout and with the approval of the permit issuing authority (PIA). The organisers must ensure that the entire entry must be able to start and leave the start area before earlier riders start subsequent laps. UNLESS an adequate filter system can be incorporated to allow riders to join the course without impeding existing competitors.

NB Where events are held on Forestry land, the number of starters in each group must not exceed 4 and the starting Interval between groups – which must be no less than 10 SECONDS – will be decided by the organiser with due regard to the course layout and with the approval of the PIA. This restriction may make it necessary for organisers to incorporate an adequate filter system to allow riders to join the course without impeding the progress of existing competitors. In all circumstances there must be a dead engine start. This may limit the size of entry. Any rider who fails to start their machine at the allotted start time for their group will be credited for that original start time regardless of the actual time that they start.

11. LAp SCORING AREA

An area must be designated which allows riders to pass through single file gates where their number will be recorded on the completion of every lap. Where there is more than one class the organizer may set alternative durations to suit the varying abilities. The organisers may stipulate that riders have to

stop, and in all instances, the lap scoring area will be regarded as a "BLUE TAPE" area and marked as such.

12. FINISH

After the specified time/number of laps, the riders will be diverted through the lap scoring area and then from the course.

13. FINISHING ORDER

The winner overall and of any respective classes will be the riders who have achieved the closest number of laps to the duration set on the allotted time. Each riders start time will be taken as their respective groups start time, or individual start time as decided by the Organiser, and their individual finish time will have been recorded.

14. TIES

Will be decided by:

- a) The number of laps completed
- b) The time taken to complete this number of laps

15. CHECKS

The start/finish will be the only time check. There should be adequate marshals/route checks on the course to prevent course cutting.

16. MARSHALS

Organisers should place marshals at strategic points around the course to monitor safety and ensure control of event.

In Youth events, Organisers should place marshals at strategic points around the course and have sufficient marshals that no part of the course is unsighted to them and any difficult sections must have a marshal present.

17. pUBLIC SpECTATOR AREAS

The Supplementary Regulations must announce the provision of clearly identified specific areas which must be used by all non-competitors other than riders or officials. Warning notices must be placed at appropriate points around the course to prevent public access.

18. REFUELLING

A suitable and restricted area must be marked out adjacent to the course as a pit area. Access to this area must be restricted to marshals, riders and authorised helpers. The area should be manned by marshals and access only allowed to officials, competitors and authorised helpers. The Organiser must establish a fire point, clearly indicated and with the appropriate fire extinguishers present. Each rider shall ensure that his refuelling crew, have a fire extinguisher at the refuelling point as described in ESR 32. 'No Smoking' signs should be displayed. The engine must be stopped during refuelling. No smoking allowed. Refuelling may only be carried out in the designated area.

ENDURO OFFICIALS

QUALIFICATIONS AND CONDITIONS

Officials are divided into two categories:
Those that are Licensed and those that are Registered.

No Fees are payable in respect of any Licences or Registration or for the appropriate form of identification issued.

LICENCES: Senior Officials are required to hold an ACU Licence of the appropriate Grade for the performance of their duties.

	See Note Below	Licence Required	Attendance at Seminar/ Training Session
Clerk of the Course	1	YES	Renew licences every third year
Chief Steward	2	YES	Renew licences every third year
Club Stewards		No	May attend Regional or ACU HQ Seminars

Clubs and Centres shall only nominate candidates whose aptitude and integrity for the position they can fully justify. Official ACU approval and the issue of a Licence is only after the candidates have proved to be competent according to the special requirements for each discipline. The respective Committees and Panels organise Seminars that are compulsory for certain Officials. A Licence is valid for 3 years.

Note 1 Clerk of the Course

GRADES

Regional must attend a seminar held by a T&E Committee member or persons first approved by that Committee.

National must attend a National seminar organised by the Trials & Enduro Committee and must also comply with specific criteria.

Note 2 Steward

GRADES

Regional will be appointed by the Centre as the Permit issuing authority as required. **National** will be appointed by the Trials & Enduro Committee as the Permit issuing authority and must also comply with specific criteria.

LICENCE FEES All licences will be issued, free of charge, for a period of three years.

Trials

Standing Regulations

TRIALS – MACHINE EXAMINER’S CHECK LIST	186
TRIALS OFFICIALS	187
ARENA TRIALS	188
ACU NORMANDALE MASTERS TRIALS CHAMPIONSHIP	190
ACU WESSEX PLANT HIRE BRITISH SIDECAR TRIALS CHAMPIONSHIP	192
ACU BELLE TRAILERS BRITISH LADIES AND GIRLS TRIALS CHAMPIONSHIPS	194
ACU S3 PARTS NATIONAL TRIALS CHAMPIONSHIP	196
ACU TRAIL BIKE SERIES INCORPORATING THE ACU TRAIL BIKE CHAMPIONSHIP	198
ACU BELLE TRAILERS BRITISH SOLO YOUTH TRIALS CHAMPIONSHIP	200

The National Sporting Code of the ACU and these Standing Regulations shall apply to all Trials together with the Supplementary Regulations and any Final Instructions issued for individual events.

DESCRIPTION

A Trial is a test of riding skill and balance over a variety of observed obstacles with riders incurring penalties for footing or for failing to fulfil other conditions.

AUTHORISATION AND LAND USE

The contents of "Procedures and safety arrangements for events using Forestry Agreement land" must be adhered to for any appropriate events.

Most events depend on goodwill from landowners, local authorities, nearby residents and other users of the countryside. For the continuance of orderly motorcycle sport, a Code, formulated by LARA has been adopted by the ACU. The Code for events with no speed element is reproduced below and will supplement the Standing Regulations. It is to be noted that where necessary disciplinary action will be taken if the Code is not fulfilled.

1. Any competitive event that is routed along, or across, footpaths or bridleways must be endorsed in advance by the Highways Authority for the area, unless the route of the event is on a highway of higher status.
2. The Organiser is responsible for obtaining authority from landowners over whose land the event passes, unless the route of the event is on a highway of higher status.
3. Where the event requires use of public highway, organisers must ensure that the Motor Vehicles (Competitions and Trials) Regulations 1969 are strictly adhered to. Events requiring authorisation must obtain this through the RAC Motor Sports Association, Authorisation Dept.
4. The Organiser is responsible for ensuring the event meets all requirements of the Road Traffic Act 1988 and the Statutory Instruments made thereunder.
5. The regulations, final instructions of an event should display the following sign: "This event is routed along and/or across public rights of way. Competitors must exercise caution and reduce their speed accordingly near other path users. Be especially careful near horses. Slow down, stop and switch off your engine if necessary."
6. The Organiser should appoint an officer responsible for event liaison. The Liaison Officer should, if appointed submit his name and address to the local Highway Authority, the Parish Council, the Police and landowners over whose land the event passes. The Liaison Officer will thoroughly investigate any complaints and try to resolve any problems arising from the event.
7. Wherever possible the Liaison Officer should maintain good relations with other path users in the area such as horse-riders, walkers, cyclists, recreational motoring groups and orienteers. The Liaison Officer should notify these groups in advance of an event where they are known to him.
8. All competitors must follow the Country Code.
9. Ensure that all aspects of the ACU Environmental Code are adhered to.

10. Emergency information

Supplementary regulations should include either a map reference or a postcode relating to the venue in order to assist the Emergency services.

NB In addition it is recommended that the map reference, farm name, address and postcode should be available at each Section together with the Mobile telephone number of the Secretary of the Meeting. The preferred method is to have this information on a card encased in a plastic wallet on a lanyard. Examples of these are available from ACU Offices.

Dogs At some venues Dogs may be prohibited. Where they are allowed, they are to be kept under control and owners are responsible for clearing up any fouling which may occur.

TSR1 ELIGIBILITY/LICENSING

All riders and passengers must hold a current ACU/SACU Trials Registration card or an ACU/SACU competition licence. Any rider or passenger from another FMN MUST produce a licence issued by their FMN together with start permission and proof of personal accident Insurance.

Where the Trial includes the use of public highways, then this will be stated in the Supplementary Regulations. If public highways are used then it is the sole responsibility of the rider to ensure that their machine is roadworthy and that they and their machine comply with all legal requirements.

RIDERS/MINDERS/ASSISTANTS AGE

- a) **Adult riders:** A rider must be at least 16 years of age to participate as an Adult.
- b) **Sidecar passengers:** In principle a Sidecar passenger must be an Adult however riders may be allowed to compete in Adult events subject to the discretion of the Trials and Enduro Committee and subject to them having a minimum age of 14 years. Nominated drivers/passengers must ride the entire event in their designated positions.
- c) **Youth Riders:** A rider must be at least 4 years of age to participate on an Electric powered machine and 6 years of age to participate in a trial using a combustion engine machine. After their 16th birthday a rider may compete as an Adult or as an A Class Youth until the end of the calendar year that they reach 17yrs and may alternate (on an event to event basis) between Youth and Adult classes subject to the following:
- whilst riding as an A Class Youth the rider is restricted to machines of an A Class Youth
 - whilst riding as an Adult, capacity restrictions do not apply.
- Any rider who competes as an Adult in the Championship Class of the Adult British Solo Trials Championship relinquishes the possibility to revert to Youth in the future.
- d) **Minders/Assistants:** In events where Minder/Assistants are allowed, their minimum age must be 18 yrs.

YOUTH AGE GROUPS

A Class	born	between	01.01.2003	and	31.12.2004
B Class	born	between	01.01.2005	and	31.12.2008
C Class	born	between	01.01.2008	and	31.12.2010
D Class	born	between	01.01.2011	and	31.12.2014

Note: To ride a Combustion engined machine the rider must have attained 6 years. E Class Minimum age – 4 years and born after 01.01.2015.

Note: The rider must have attained 4 years at the date of the competition.

NB IMPORTANT INFO FOR B/C CLASS RIDERS IN 2020

Riders who reach the age of 12 in 2020 (ie born after 31.12 2007) will have the option of either:

- Moving to the B class in the year in which they reach 12 yrs on a machine up to 125cc (and being eligible for B Class points)

NB : The rider must be 12 years of age at the date of competition to ride a machine of 125cc Mono

OR

- Remaining in the C Class for another year on a machine of up to 80cc and retaining eligibility for C Class points.

ENGINE CAPACITY/WHEEL SIZE FOR ABOVE AGE GROUPS

The maximum permitted for machines used in the Age Groups set out in this Regulation are as follows:

A Class

125cc Mono or up to 250cc Twinshock** combustion engine, and Electric up to 10bhp measured at the rear wheel.

B Class

125cc Mono or up to 250cc Twinshock** combustion engine, and Electric up to 10bhp measured at the rear wheel.

** Twinshock machines over 125cc must have twin rear suspension units and drum brakes as at the time of manufacture.

C Class Standard Wheel

80cc combustion engine, and Electric up to 7bhp measured at the rear wheel

C Class Medium Wheel

80cc combustion engine

Electric up to 7bhp measured at the rear wheel

D Class with Medium Wheel

80cc combustion engine

Electric up to 7bhp measured at the rear wheel

D Class with Small Wheel

80cc Combustion Engine

Electric up to 7bhp measured at the rear wheel

E Class

Small wheel Electric powered machines up to 2bhp measured at the rear wheel.

Wheel sizes

Standard Wheel – 21" Front – 18"

Rear Medium Wheel – 19" Front –

17" Rear Small Wheel – 16" Front –

14" Rear

A rider must enter the class which corresponds with the wheel size of his/her machine. The above is based on the wheels of combustion engine machines using motorcycle tyres. If other wheels are used as on current Electric powered machines then the outside diameter (total circumference) of the tyre must not exceed that of the corresponding tyre size.

Engine Sizes

Rebores are permitted subject to the resulting engine capacity not exceeding a tolerance of +3cc.

Criteria for riders wishing to ride in any higher class:

- Events below National status – a rider may compete in any class higher than that of his/her age group at the discretion of the organizers.
- National status competitions – a rider may at the discretion of the Trials and Enduro Committee be permitted to ride in the higher class. Applications to be made in writing.

Criteria for riders wishing to ride in any lower class:

- A rider may enter any event in a class below that of his/her age group on a "no award, no points" basis.

In all cases the rider must always comply with the maximum capacity and wheel size for their actual age.

TIME AND OBSERVATION RULES FOR YOUTH TRIALS (A & B CLASS RIDERS)

1. Qualified First Aid Personnel with equipment and transport must be in attendance.
2. The course must be marked in such a manner that excludes sharp corners and blind bends wherever possible.
3. Travelling Marshals will be provided to give at least one per two miles of course.
4. The Regulations must include the note "This Event is not recommended for Novice Riders".
5. The general public are to be discouraged from entering the area of the course.
6. Any other Youth class riders are only allowed to participate after prior approval of the Trials and Enduro Committee.
7. A Steward appointed either from ACU Headquarters or from the Local Centre should be in attendance.

TSR2 ENTRIES

An Event Entry Form must be completed in every detail, and signed by each rider and passenger. Each completed entry form, together with the entry fee (which includes riders/passengers insurance premiums for personal accident and off road risks) and Entry Subscription (see NSC 7.05) shall be forwarded to the Secretary of the Meeting. NB See also TSR 29 – Insurance.

All riders, passengers and appointed persons responsible for minors, must register arrival at an event by signing-on at the event control office, or other designated area, not less than 30 minutes prior to commencement of the competition.

Riders and Passengers under 18 years of age (Minors): In order to conform with the Children Act legislation, additionally, for every rider or passenger who is under 18 years of age a Parental Agreement must be signed. The Parental Agreement is incorporated in the Annual Competition Licence and Trials Registration form and once completed will serve as the riders Annual Parental Agreement. All minors will be bound by the directions of parent(s), guardian(s) or other appointed adult responsible for them at any event. The following guidelines apply:

Minors Under 14 The Parental Agreement must be signed by a parent or legal guardian who must also be present when the rider competes.

Minors Aged 14 or 15 The Parental Agreement must be signed by a parent or legal guardian who must also be present when the rider competes unless they have specified another responsible adult who may sign for and accompany the rider at events.

Minors Aged 16 or 17 The Parental Agreement must be signed by a parent or legal guardian. There is no requirement for the minor to be accompanied to events by an adult.

Child Protection: The point of contact for Child Protection issues will be the Secretary of the Meeting unless otherwise stated in the Supplementary Regulations.

TSR3 LIMITATION OF ENTRIES

Any limitation on the maximum or minimum number of entries to be accepted, together with the method of limitation (e.g. in order of receipt, by ballot, etc.) must be included in the Supplementary Regulations.

TSR4 WARNING NOTICES

Organisers should display Warning Notices at the event, recommended to be placed at any point of the course where the public is likely to congregate.

TSR5 TEAM NOMINATIONS

TEAM-ONLY COMPETITIONS (E.G. INTER CENTRE).

All riders and passengers must sign an entry form and all entries must be made via an appointed Team Manager.

TRIALS INCORPORATING COMPETITION FOR TEAMS.

Teams shall consist of riders who have entered individually and such riders must complete a declaration on the entry form signifying their consent to nomination as a team member.

TYPE OF TEAM

- a) **Club Teams.** A rider must be a registered member of the nominating Club and may be nominated as a member of one Club Team only.
- b) **One Make of Manufacturers' Teams.** Teams shall consist of riders all riding machines of the same manufacturer.

Details of further teams if any shall be contained in the Supplementary Regulations.

TSR6 CHANGE OF RIDER

All entries will be deemed to be in respect of the rider so named and no change of rider will be permitted except in the case of "Team Only" competitions where the Team Entry is submitted by a

Team Manager. For "Team Only" competitions any change of an individual entry will be subject to the conditions of the Supplementary Regulations.

TSR7 CHANGE OF MACHINE AND/OR PASSENGER

Any request for change of machine and/or passenger must be made in writing and submitted to the Secretary of the Meeting at least one hour prior to the start of the event. The same machine must be used throughout the event. In the case of a sidecar this is deemed to be an integral part of the machine.

TSR8 MOTORCYCLES

Motorcycles must comply with Appendix D of the National Sporting Code. Prior to the start of each Event all machines shall be examined to ensure that they comply with ACU specifications. When the event uses the public highway it is the sole responsibility of the rider to present a machine complying with all Road Traffic Act(s) requirements Organisers may at their discretion, allow riders to share the same machine in a Closed to Club Trial held on private land.

SOLO: Motorcycles propelled by the action of one wheel in contact with the ground and making only one track on the ground. Machines must have independent brakes on both front and rear wheels.

Brake and Clutch levers. All handlebar levers (clutch, brake etc.) must be in principle ball ended. These ends must be permanently fixed and form an integral part of the lever.

Mudguards must be fit for purpose and corresponding to the original equipment.

Footrests must be of the folding type.

Throttle must be self closing when not held by the hand. The machine may be set with a "tickover". **Wheels** If of cast, or fabricated construction (other than conventional spoked wheels) then protection must be provided to the rear wheel by the fitting of 'solid discs' to cover open areas.

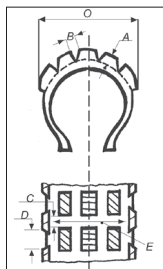

Tyres. Only tyres which conform to the following specification may be used.

All tyres will be measured mounted on the rim inflated to a pressure of 14lb/sq.in, and must have a nominal aspect ratio of 100/100. Overall width (O) measured at wheel spindle height must not exceed 115mm. (Refer to diagram). Tread depth

(A) must not exceed 13mm. All tread blocks in the same circumference must be of the same depth. The space between the tread blocks (B) must not exceed 9.5mm across the tyre or 13mm in a circumferential direction (C). The space between the shoulder blocks (D) must not exceed 22mm.

The space across the tread (E) must not extend completely across the tyre measured at right angles to the tyre wall unless broken by a block. All main tread blocks must in principle be parallel with or at right angles to the tyre axis. (Tyre must have the same appearance if reversed and conform in principle with these diagrams). The tyre

surface must not be fitted with any subsequently mounted elements such as anti-skid devices, chains, etc. NB: Only tyres available from commercial sources and complying with these dimensions are permitted in competitions. Where the event uses the public highway, tyres must be manufactured to comply with European Tyre & Rim Technical Organisation and have the relevant markings.

Tyres for Long distance Trials Tyres Spec as per TSR8 for ACU Trail Bike Championship events.

Tyres used in non-championship events must be road legal and the tread pattern is to be at discretion of the organisers and as stated in the Supplementary Regulations.

Cutout Device. With the exception of Four Stroke Sidecar machines fitted with external magnetos ignitions, all machines used in Youth and Sidecar competitions must be fitted with an operational lanyard cut out device so as to stop the engine/motor should the rider and machine be parted. The lanyard from the cut out device must be securely fitted to the rider and be of a length not greater than 1m when fully extended.

It is recommended that all machines used by Adult riders be fitted with a lanyard operated cut out device as described above.

Chainguards must be fitted to all motorcycles as per manufacturer's specification.

Engine Measurement Where it becomes necessary for the ACU or an organiser to verify any fact relating to an engine size, it shall be carried out at the cost of the rider. Where an engine is measured, as the result of a protest, the protest must be submitted with the appropriate fee plus a deposit of £250.00 which can only be returned if the protest is upheld. If the protest is unsuccessful then the deposit will be awarded to the person against whom the protest has been made and the protest fee will be sent to the ACU Benevolent Fund. The Clerk of the Course shall judge as guilty anyone who refuses to present an engine for measurement. A rider whose machine is found to have an engine size not complying with the rules will be disqualified and will be liable to further disciplinary action. If engines are presented for measurement, but this cannot be carried out at the event, the engines must be sealed for later measurement. If seals are damaged or removed the rider will be disqualified and subject to a fine.

TRIALS SIDECAR SPECIFICATION

All motorcycles in Categories B (1), B (2) and B (3) shall comply with the following requirements:

- a) The entire body, including the floor, shall be either sheet metal or other substantial material, and the Sidecar must be rigidly fixed to the motorcycle.
- b) Minimum dimensions shall be:
 - A. Measurement from the nose to dashboard – 375mm (15")
 - B. Overall length nose to tail – 1350mm (54")
 - C. The height of the body at the apex of the dashboard position – 375mm (15")
 - D. The overall distance between the outside of the Sidecar mudguard or bodywork and the inside of the passenger's seat measured at right angles to the machine track – 300mm (12")
 - E. Width of body at forward end – 150mm (6")
 - Depth of body at forward end – 150mm (6") OR if the forward end is hemispherical and radius shall be not less than 75mm (3")

F. Track – minimum 876mm (34 1/2")

The distance is measured from the centre of the track left by the rear wheel to the centre of the track left by the front wheel.

G. Overall width of cockpit at seating position – 300mm (12")

A seat measuring not less than 180mm (7.5") x 125mm (5") must be fitted. The height of the seat shall be not less than 300mm (12") from the floor of the sidecar.

- c) The fitting of grab rails, handles, straps etc shall be according to the driver's requirements.
- d) Protection for the passenger must be provided from the rear wheel, the primary and final drive of the motorcycle, and from the sidecar wheel, by means of either a mudguard or the coachwork of the sidecar.
- e) The use of sidecar wheel drive is prohibited.

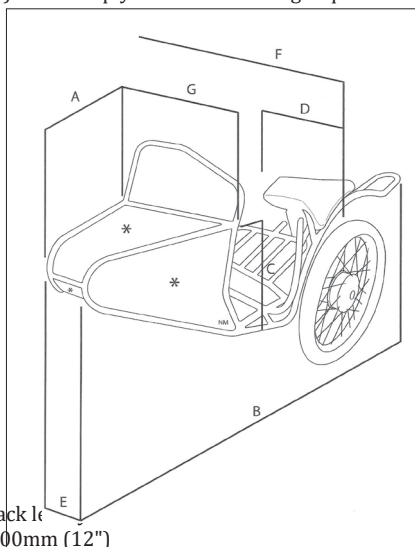

TSR 9 FUEL

Commercially available unleaded fuel must be used. Power boosters or octane boosters are forbidden. Refuelling must not take place when the engine is still running. Mobile Phones must not be used in refuelling areas.

ENVIRONMENTAL MATS

All machines and generators must stand on an Environmental mat whilst being refuelled.

TSR10 TELEMETRY

The use of Telemetry between the rider/motorcycle and any other person/equipment by radio means is not allowed.

TSR11 RIDING NUMBERS

Riding numbers issued by the organisers, whether card or numbered bibs must be clearly displayed in a legible condition throughout the competition. Riding numbers shall not be defaced in any way and no event sponsors advertising shall be covered. Riding numbers shall be removed at the Finish. Where there are different section routes for different classes of rider, each rider shall be issued with a means of identification to reflect the route the competitor is riding.

TSR12 CLOTHING

Clothing must cover legs and body and it is recommended that arms should be covered. Boots of approximately knee length made of leather, rubber or plastic must be worn. The wearing of gloves is recommended.

Motorcycle helmets Competitors, both riders and Sidecar passengers must wear a correctly fitted helmet at all times during the event whilst riding a motorcycle or quad. Officials must wear a correctly fitted helmet whilst riding a motorcycle at all times during the event, and it is recommended that they wear a helmet whilst riding a quad. Unless the helmet is manufactured with the camera as an intrinsic part, helmet cameras (including the helmet camera brackets) and cameras attached to the body are prohibited. Cameras attached to the machine are permitted.

Jewellery Competitors are advised not to wear hand, face or body jewellery which could prove hazardous in the event of an accident. The mouth should be kept clear of anything likely to cause a blockage of the airway in the event of an accident, e.g. chewing gum.

Youth All Youth competitors must have clothing covering arms and wear gloves covering hands and fingers.

TSR13 PILLION PASSENGERS

The carrying of pillion passengers is not allowed except where provision has been made for this in the Supplementary Regulations.

TSR14 CONTROL OF EXHAUST SOUND LEVEL

The sound level of a Trials machine controlled according to the ACU method and measured at 2 metres distance will not exceed 100 dBA (For precise method of testing, see Sound Control Regulations in this Handbook).

There may be one or more random sound level tests during the event for which the rider will not be allowed to make any adjustments. A rider whose machine exceeds the maximum permitted sound level or does not present his machine in a testable condition will face immediate disqualification and must return to the finish as directed. Additionally, at any time during the event, the Clerk of the Course or the appointed official is empowered to disqualify any machine he considers excessively noisy.

TSR15 START AND FINISH

Prior to Starting, the rider must have signed on, had his/her machine examined and be suitably dressed. All riders, including riders who have retired, must report to the Finish where they may be required to sign off. The method of deciding the starting order will be stated in the Supplementary Regulations or, where applicable, in the appropriate Championship Regulations.

TSR16 TIME

For Trials other than Time and Observation Trials, where full details regarding the calculation of time penalties shall be included in the Supplementary Regulations, the following shall apply; if a time restraint is applied to part or all of the Trial, it shall be in the form of an individual allowance for each rider and the details given in the Supplementary Regulations or Final Instructions. Wherever a Time restraint is applied there must be a Clock showing the Official time visible to all riders at each time control point.

A rider's Time Allowance shall commence from the actual time the rider starts. The location of the final Time Control should be at the last section, or as close as practical. Riders will be penalised one mark per minute or part of that minute up to a maximum of twenty for late starting, and for arriving late at any subsequent Time Control, and thereafter disqualified.

It is recommended that the time limit shall not be extended other than in the case of Force Majeure as determined by the Clerk of the Course.

TSR17 COURSE/ROUTE

The Clerk of the Course must ensure that due consideration is given to the age and abilities of the riders when planning and marking the course and that suitable marking is displayed to guide and restrict any spectators/members of the Public who may attend.

The onus of following the correct route rests entirely with the rider. A rider leaving the course must rejoin it at the same point. When public roads are used to connect areas of private land a map clearly showing their position must be displayed at the Start or in the programme. The onus of finding these areas of private land rests entirely upon the rider and any route marking provided by the organisers is purely for assistance. The Clerk of the Course reserves the right to modify the route. To qualify as a finisher and be eligible for an award, with the exception of a section where the rider has recorded

a failure, the rider's machine must have travelled the whole distance under its own power or the exertion of the rider and passenger. Any rider, who on any private land is accompanied by another vehicle unconnected with the event, is liable to disqualification. Any competitor who is, in the opinion of the Clerk of the Course, considered to be riding the course for the benefit of another competitor is liable to disqualification and reporting to the Stewards for further disciplinary action.

If route marking is appropriate it is recommended that discs (square, round, etc – not arrows) are used to signify the direction – red for right, blue for left and white to straight on. It is suggested also that where a red or blue disc is used then following the turn, there should be a white to assure the rider that the correct route has been taken.

TSR18 OBSERVED SECTIONS

The organiser must display which route each class is riding indicating the corresponding colours of the route marking. Details may be displayed at signing on, at the first section or contained in the Final Instructions or programme. Riders in the same class must all start at the same section.

It is recommended that routes be marked as follows:

Route 1 – Principal Route – Blue (left) Red

(right) Route 2 – Yellow both sides

Route 3 – White both sides

Any further routes to be marked in a colour chosen by the Organiser.

In the above, the letters denote the severity of the sections in descending order ie Route 1 would be hardest, Route 2 next hardest and so on.

Routes may be marked in their entirety in the colours shown – or the Organiser may mark appropriate diversions in these colours. Ideally – the coloured section of markers should be in the shape of an arrow – with the point toward the centre of the section.

No penalty shall be imposed on a rider who wishes to inspect a section before riding it.

The lateral limits of an Observed Section or Sub Section may be defined by artificial boundaries such as markers or tapes, which shall be firmly placed and positioned in a way so as to clearly define the

intended limits of the section. If tapes are to be used they shall always be clear of the ground but not exceed a height of 500mm from the ground.

The Start and Finish of each Observed Section or Sub-Section will be clearly defined, with the Section Begins and Section Ends identified as such.

Sections and Sub-Sections shall be numbered or lettered and ridden in the correct sequence unless otherwise instructed by the organisers.

A rider failing in a Sub-Section must restart in a forward direction from the Sub-Section in which he has failed.

To qualify as a Finisher and be eligible for an award, the competitor must be deemed to have made a bona fide attempt at least 75% of the sections.

TSR19 PUNCHCARDS

If punchcards are used, the onus of looking after these rests entirely on the rider and only the rider/ passenger may present the punchcard to the observer. Any disagreement over the score punched, or errors must be reported to the Secretary of the Meeting immediately upon completion of the

event. The Observer must be informed that this action is being taken as any error not verified by the Observer shall not be accepted. Refusing to have the card punched, deliberately disfiguring or losing the punch card will result in disqualification for which no protest will be accepted. Any rider who does not return his punchcard to the appointed Official without delay will be classed as retired.

TSR20 OBSERVERS

An Observer is an assistant to the Clerk of the Course appointed to judge a competitor's performance in an Observed Section. No protest or appeal can be accepted against a judgement of performance made by an Observer, however, a protest may be accepted against any breach, or misinterpretation of the Regulations.

A mistake made by an Observer may be corrected by the Observer with the approval of the Clerk of the Course.

TSR21 INSTRUCTION TO RIDERS

Any instruction to riders not included in the Supplementary Regulations (Final Instructions) must be approved by the permit issuing authority if issued prior to the event, or approved by the Stewards of the meeting if issued at the event.

Subject to being issued in one of the following ways they shall have the same force as these Standing Regulations.

- Issued in writing and distributed to each rider.
- Issued via a clearly situated notice board.
- Via a riders briefing meeting, providing all riders have been informed formally of the venue and time of such a meeting.

TSR22 METHOD OF MARKING

A machine will be deemed to be in an Observed Section or Sub-Section when the front wheel spindle has passed the 'Section Begins' Card and until the front wheel spindle has passed the 'Section Ends' Card. Marks will be lost as follows:

A. STOP PERMITTED

- | | |
|---|---|
| 0 | Clean |
| 1 | Footing once |
| 2 | Footing twice |
| 3 | Footing more than twice |
| 5 | Failure |
| 5 | When requested by a rider rather than attempt the section |
| 5 | Entering a section before being called upon to do so by an official |

- 10 Not attempting a section when called upon to do so by an official
- 10 For missing a section or failing to have punch card marked.

Graded Hills. Where a Section is to be termed a 'Graded Hill' a notice to that effect must be displayed at the Section Begins, and the following shall apply: Numbered boards must be placed at defined places along the Section, in order that a rider's performance may be determined.

Marks will be

lost in a decreasing manner from 5 to 0 depending on the distance a rider can traverse the Section without failure. The front wheel spindle is the part of the machine to be used in assessing the distance traversed.

Footing is allowed without penalty.

- 0 Clean
- 1 Reaching or passing the "1 Board" without Failure
- 2 Reaching or passing the "2 Board" without Failure
- 3 Reaching or passing the "3 Board" without Failure
- 5 Failure to reach the "3 Board"
- 5 When requested by a rider rather than attempt the section
- 10 Not attempting a Section when called upon to do so by an official
- 10 For missing a section or failing to have punch card marked.

DEFINITIONS

Clean: A rider traversing a Section as defined above without penalty as described under FOOTING or FAILURE shall be unpenalised and given a "CLEAN".

Footing: Footing will be considered to have occurred if any part of the rider's body or any part of the machine, (with the exception of the tyres or the sump shield) touches the ground or the rider benefit from any part of their body, or any part of the machine, (with the exception of the tyres or the sump shield) leaning on an obstacle (tree, wall etc.)

Footing outside the lateral limits of a Section does not constitute a failure but should simply be classed as footing.

Failure: A failure is considered to have occurred if:

- a) The machine moves backwards.
- b) The rider does not have both hands on the handlebar WHEN HE FOOTS WHILST STATIONARY.
- c) The engine stops WHILST ANY PART OF THE MACHINE, WITH THE EXCEPTION OF THE TYRES, TOUCHES THE GROUND OR THE RIDER IS FOOTING.
- d) The rider dismounts from the machine. Dismount will be deemed to have occurred when both of the rider's feet are on the ground at the same side of, or behind the machine.
- e) A machine does not stay within the intended limits of the section as defined by the Observer.
- f) If any wheel of the machine crosses any boundary tape or goes over or on the wrong side of a marker, whether the wheel be on the ground or airborne, before the front wheel spindle passes the "Section ends" sign.
- g) The rider is held responsible for displacing a marker or support in an observed section whereby the observer considers it necessary to reinstate the flag/marker prior to the passage of the next rider. The displacing of any marking not relating to the competitor's route will be considered to constitute a failure.
- h) Travelling in a forward direction against the direction of the Section.
- i) The motorcycle crosses its own track with either wheel.
- j) The machine or rider receives outside assistance.
- k) A rider or person having an interest in a rider's performance, who in any way alters the severity of a section without the authority of an official.

Note: A rider not exiting the section after recording a failure when requested to do so by the Observer will be awarded an additional penalty for causing unnecessary delay.

For all trials other than those for which Championship Regulations apply the organiser may, with the agreement of the Permit Issuing Authority, apply a time limit to each section. The time allowed must be the same for each and every Section and the penalty for a rider not completing the Section within that time would be failure. If a time limit is to be applied to the Sections then this must be clearly stated in the Supplementary Regulations.

B. NON-STOP (SOLO & SIDECAR)

- 0 Clean
- 1 Footing once
- 2 Footing twice
- 3 Footing more than twice
- 5 Failure
- 5 When requested by a rider rather than attempt the section
- 5 Entering a section before being called upon to do so by an official
- 10 Not attempting a section when called upon to do so by an official
- 10 For missing a section or failing to have punch card marked.

Graded Hills. Where a Section is to be termed a 'Graded Hill' a notice to that effect must be displayed at the Section Begins, and the following shall apply: Numbered boards must be placed at defined places along the Section, in order that a rider's performance may be determined. Marks will be

lost in a decreasing manner from 5 to 0 depending on the distance a rider can traverse the Section without failure. The front wheel spindle is the part of the machine to be used in assessing the distance traversed.

Footing is allowed without penalty.

- 0 Clean
- 1 Reaching or passing the "1 Board" without Failure.
- 2 Reaching or passing the "2 Board" without Failure.
- 3 Reaching or passing the "3 Board" without Failure.
- 5 Failure to reach the "3 Board".
- 5 When requested by a rider rather than attempt the section
- 10 Not attempting a Section when called upon to do so by an Official
- 10 For missing a section or failing to have punch card marked.

DEFINITIONS

Clean: A rider traversing a Section as defined above without penalty as described under FOOTING or FAILURE shall be unpenalised and given a "CLEAN".

Footing: Footing will be considered to have occurred if any part of the rider's body or any part of the machine, (with the exception of the tyres or the sump shield) touches the ground or the rider benefit from any part of their body, or any part of the machine, (with the exception of the tyres or the sump shield) leaning on an obstacle (tree, wall etc.), Footing outside the lateral limits of a Section does not constitute a failure but should simply be classed as footing.

Failure: A failure is considered to have occurred if:

- i) The machine ceases to move in a forward direction.
- ii) The rider dismounts from the machine. Dismount will be deemed to have occurred when both of the rider's feet are on the ground at the same side of or behind the machine.
- iii) A machine does not stay within the intended limits of the section as defined by the Observer.
- iv) If any wheel of the machine crosses any boundary tape or goes over or the wrong side of a marker, whether the wheel be on the ground or airborne, before the front wheel spindle passes the "Section ends" sign.
- v) The rider or passenger is held responsible for displacing any marker or support in an observed section whereby the observer considers it necessary to reinstate the flag/marker

- prior to the passage of the next rider.
The displacement of any marking not relating to the competitor's route will also be considered to warrant a failure.
- vi) The machine or rider travels in a forward direction against the direction of the Section.
 - vii) The motorcycle crosses its own track with either wheel.
 - viii) The machine, or rider or passenger receives outside assistance.
 - ix) A rider or person having an interest in a rider's performance, in any way alters the severity of a section without the authority of an official.

For Sidecar events only.

A failure is considered to have occurred if:

The passenger foots i.e. if any part of the passenger's body touches the ground, or benefit is gained from any part of his body leaning on an obstacle (tree, wall etc.).

Note ACU Trial GB method of marking: see Championship Regulations for description. Only to be used in ACU Trial GB events

TSR23 TIES

A) Ties in an Event

Ties will be resolved by the following method in the sequence shown:

- a) In favour of the rider with the highest number of cleans.
- b) In favour of the rider with the highest number of one mark.
- c) In favour of the rider with the highest number of two marks.
- d) In favour of the rider with the highest number of three marks.
- e) In favour of the rider who travelled furthest with the least marks lost.
- f) In favour of the rider who completes the course with the least marks lost on time.

If not resolved by the above **and the organiser has stated so in the Supplementary Regulations** then a special test may be used for final deciding of ties.

If the event is part of a Championship and if a tie cannot be resolved in accordance with the above those involved in the tie will be allocated the Championship points of the highest place for which the tie exists.

B) Ties at the end of a Championship Series.

Should a tie occur in a Championship series it shall be decided as follows:

- a) In favour of the rider with the greatest number of wins in ALL rounds held.
- b) If not resolved then the greatest number of second places and so on down to 15th place in ALL rounds held.
- c) If not then resolved, by the rider with the best performance in the final event held. If neither rider competed in the Final round, the highest position will be awarded to the rider of the last round in which either competed.

TSR24 FINAL ASSESSMENT OF CHAMPIONSHIPS

The Championship Regulations for any Championship must state the number of rounds to count for the Final Assessment eg: "All rounds to count" or "All rounds held less one, or all rounds less two to count". If no indication is stated then it will be assumed that all rounds held will count.

TSR25 BAULK

A baulk is deemed to have occurred when a rider, whilst attempting an observed section, is prevented from making a bona-fide attempt due to some outside obstruction. Should a rider claim a baulk, the Observer may, at his discretion, allow a re-run of the section. The Observer's decision as to whether a re-run is permitted is final. Should a re-run be granted, any marks lost prior to the point of the baulk on the original attempt shall stand, and the section shall be observed from the point of the baulk.

Regarding any time allowed for the section the re-run shall start from the Section Begins and the time will be measured for the total section as if no obstruction had taken place.

TSR26 pRACTISING

Unofficial practising at the venue is prohibited. A breach of this regulation renders the rider liable to disqualification from the event and to be reported to the stewards of the meeting for disciplinary action. If official practice is to be allowed, either in a suitable area away from the paddock, or on the sections to be used, then full details must be stated in the Supplementary Regulations or relevant Championship Regulations.

Where another event takes place at the same venue it will not be considered to constitute unofficial practice.

TSR27 pREJUDICIAL ACTION

Any person having an interest in a rider's performance, who takes any action prejudicial to the sport may be liable to a penalty up to and including disqualification. Riders, parents or associates failing to obey instructions given by officials of a meeting or deemed to have unjustifiably or maliciously jeopardised the efficient running of the meeting by not adhering to the Regulations, Supplementary Regulations or the Protest or appeal procedure, may render the rider liable to a penalty up to and including disqualification and being reported to the permit issuing authority for further action.

TSR28 LEGAL ACTION

A rider who is convicted following a police prosecution for an offence committed by them whilst taking part in the competition may be liable to disqualification.

TSR29 INSURANCE

The responsibility is on the rider to ensure that his motorcycle complies with all legal requirements. The organisers will be required to cover riders and passengers against Personal Accident risk and for Third Party Insurance for 'off-the-road' risks whilst taking part in the event and the premium for such insurance will be included in the entry fee. The ACU have arranged third party RTA Insurance as a blanket cover across the whole Membership to cover any competitor, marshal or Official signed on for an ACU permitted event which, for the duration of the permit, will allow them to use any motor vehicle in connection with the event in areas of the event where the Road Traffic Act is deemed to be applicable. The RTA cover will be provided in the same way as the ACU Public Liability and other insurance covers. That is to say when the Rider, Marshal or Official signs on at an event, the cover is automatically in place. The RTA cover comes at no extra cost to the Organiser as this cover is provided free of charge by the ACU.

TSR30 ABANDONMENT

The organisers reserve the right, subject to the approval of the Stewards of the Meeting, to cancel, postpone or abandon the competition, if circumstances should arise which in their opinion, render such action necessary.

TSR31 MEDICAL SERVICES

It is recommended that a person holding a certificate of First Aid competency be present at all events. In addition it is recommended that the organiser shall be conversant with the nearest Accident/ Emergency Services and ensure they have a means of contacting them. Where ambulances are in place, by law, they must be registered with the DVLA and be CQC-registered in order to transport a casualty to hospital. An ambulance must have an appropriately qualified driver to transport a casualty under blue lights. Organisers must also refer to the "Medical Services and Definition" section of this Handbook.

Concussion/suspected concussion

If a competitor is involved in an incident which results in him being diagnosed by the Medical Officer/Paramedic as suffering from concussion or suspected concussion, the rider is not permitted to participate any further in that event.

Organisers are to notify ACU Head Office as soon as possible of any concussion or suspected concussion injuries and then will subsequently:

- a) Place the rider on the ACU Stop List
- b) Inform Organisers of forthcoming events that the Rider has suffered a concussion or suspected concussion injury and is therefore placed on the ACU Stop List
- c) Inform the Rider that he needs to see a Doctor and obtain a letter/doctor's certificate which confirms he is fit to resume competitive racing/participate in a practice/test session.

The recovery time for anyone diagnosed with concussion or suspected concussion is as follows:

- a) Over 20 years: Excluded immediately and suspended for a period of nine days.
- b) 16–19 years: Excluded immediately and suspended for a period of twelve days.
- c) 15 and under: Excluded immediately and suspended for a period of twenty three days. The rider is not permitted to ride during the obligatory suspended periods outlined above and then only once he is in possession of a doctor's certificate/letter after the suspended period has expired. If a competitor has been injured on a Saturday and is suffering from concussion or suspected concussion, and the Organiser is aware that the rider was intending to ride or is scheduled to ride somewhere else the next day, the Organiser will inform the Organiser of the event being held the next day so they are aware of the rider's injuries and as such he is prevented from participating in that event.

TSR32 LIABILITY FOR DAMAGE

A rider is liable for any damage caused by themselves, their passenger, or any agent, representative or servant acting on their behalf, during the meeting. The promoters may act as agents for such persons to agree and pay for any such damage, and the rider shall on demand reimburse the promoters any sum so paid.

TSR33 DISCLAIMER

It is condition of acceptance of entry that the promoters shall not be responsible for any damage to, or loss of a motorcycle or its accessories whether by fire, accident or any agent, representative or servant acting on their behalf, during the meeting.

TSR34 OFFENSIVE BEHAVIOUR

Any rider, or party with an interest in a rider's performance, reported to the Clerk of the Course for arguing or being offensive to an Observer, or other Official, renders that rider liable to disciplinary action. Where the Organiser supplies the Observer with a Yellow Card, the Observer may issue it to any rider who continues to hassle or abuse the Observer following a warning. Any rider who is issued a Yellow card will be reported to the Clerk of the Course who may issue further disciplinary action. The Organiser must report to the T&E Committee all incidents where disciplinary action has been taken for Offensive Behaviour.

TSR35 YOUTH AWARDS

Cash awards and gift vouchers are not permitted for Youth classes.

TSR36 JOINT ADULT/YOUTH EVENTS

Subject to the agreement of the Permit issuing Authority a Youth Class/Classes may be included in Adult events. Youths to ride the route as decided by the Clerk of the Course. A Youth must ride a machine of a maximum capacity/power and wheel size as appropriate to their age.

Adults and Youths must compete for separate awards.

TSR37 COMPLIANCE WITH REGULATIONS

Every rider, by entering or being nominated, thereby acknowledges that he is bound by the National Sporting Code of the ACU and these Standing Regulations together with any Supplementary Regulations and Final Instructions to be hereafter issued, to all of which he undertakes to submit and moreover renounces any right to have recourse to any arbitration or tribunal not provided for in the said Rules and Regulations.

TSR38 RESULTS

For each event a set of Results must be produced which display the event date and Permit number. The method to be used for the publication of the results must be shown in the Supplementary Regulations or the Championship Regulations. Acceptable formats are by post, email or website but in addition for every event a set of provisional results must be sent, either by post or by email, to the Permit issuing authority. These must clearly show the date and time of publication. If these provisional results are amended then a copy of the revised set, clearly marked "Amended (date)" must be sent by post or email to the Permit Issuing authority and any rider affected by the amendment.

TSR 39 pROTESTS

See Appendix B of this Handbook.

Where it has been previously stated in the Championship Regulations or Supplementary Regulations that the results will be announced at the conclusion of the event and the full results, signed by the Clerk of the Course (or appointed official) with the time of day, are displayed within 30 minutes of the last rider finishing, any protest must be submitted within 30 minutes of the time of signing.

Where the above for any reason does not apply (e.g results are announced later, sent by post, email or published on a website) any protest must be submitted within 5 days of publication. The date of publication of results must be shown on the results displayed on a website or sent by email, or confirmed by postmark if mailed and the Protest period will commence from this date. Protest against the Capacity/power of a motorcycle must be accompanied by a deposit of £250 to cover associated costs.

TSR40 pOWER WASHERS

It is prohibited to use power washers, unless the organisers offer suitable facilities which comply with the ACU Environmental Code.

TSR41 FIRE EXTINGUISHERS

There shall be at least one fire extinguisher at the start of each event and at any subsequent designated refuelling areas. (Mobile phones must not be used in designated refuelling areas).

TSR42 INTERpRETATION

The interpretation of these Standing Regulations and the Supplementary Regulations or Instructions to rider will rest entirely with the Stewards of the Meeting whose decision shall be final and binding except as provided in the National Sporting Code.

TRIALS – MACHINE EXAMINER'S CHECK LIST**GENERAL TRIALS**

Machines should be in general good condition with no obvious parts missing or not working. Should be adequately silenced and the following checked:

- Brake and Clutch levers should have in principle ball ended levers
- Folding Footrests
- Self closing throttle

- Have trials tyres
- Have a helmet and suitable boots

For **youth competitors** the additional items should be checked:

- Operation of cut out device
- Correct engine and wheel size size for age of rider
- Have gloves and the forearms covered

And **sidecars** should have:

- Operation of cut out device
- A nose cone
- Seat for the passenger
- Passenger has helmet and suitable boots

For entries in ACU Championships please refer to current Championship Regulations.

TRIALS OFFICIALS

QUALIFICATIONS AND CONDITIONS

Officials are divided into two categories: Those that are Licensed and those that are Registered. No Fees are payable in respect of any Licences or Registration or for the appropriate form of identification issued.

LICENCES: Senior Officials are required to hold an ACU Licence of the appropriate Grade for the performance of their duties.

	See Note Below	Licence Required	Attendance at Seminar/ Training Session
Clerk of the Course	1	YES	Renew licences every third year
Chief Steward	2	YES	Renew licences every third year
Club Stewards		No	May attend Regional or ACU HQ Seminars

Clubs and Centres shall only nominate candidates whose aptitude and integrity for the position they can fully justify. Official ACU approval and the issue of a Licence is only after the candidates have proved to be competent according to the special requirements for each discipline. The respective Committees and Panels organise Seminars that are compulsory for certain Officials. A Licence is valid for 3 years.

Note 1 Clerk of the Course

GRADES

Regional must attend a seminar organised by a Centre/Region.

National must attend a National seminar organised by the Trials & Enduro Committee and must also comply with specific criteria.

Note 2 Steward

GRADES

Regional will be appointed by the Centre as the Permit issuing authority as required. **National** will be appointed by the Trials & Enduro Committee as the Permit issuing authority and must also comply with specific criteria.

LICENCE FEES All licences will be issued, free of charge, for a period of three years.

Arena Trials

The National Sporting Code of the ACU and these Standing Regulations shall apply to all Arena Trials together with the Supplementary Regulations and any Final instructions issued for individual events.

1 GENERAL

- 1.1 **Description.** An Arena Trial is a test of riding skill and balance over a variety of observed obstacles with riders incurring penalties for footing or for failing to fulfil other conditions. The obstacles (Sections) are usually man made, specifically for the event which is held within an arena or stadium. The Standing Regulations for Trials (TSRs) as printed in this Handbook shall be applicable with the following amendments.
- TSR3** Entries shall be by the invitation of the organising Club.
- TSR20** The order in which the Sections shall be attempted must be explained to the riders at the briefing meeting.
- TSR21** Any obstacle which is more than 1000mm from the ground and has a width of less than 500mm shall have a firm support below and along the full length of the said obstacle. The "Start" and "End" of each Section shall be clearly marked and the lateral limits clearly explained at the briefing meeting.
- TSR22** The method of marking shall be to TSR22A.
- TSR28** Prior to the start of the above event the Clerk of the Course must hold a briefing meeting which must be attended by all riders, the Referee and the Observer(s). The Clerk of the Course must inform the riders of the lateral limits of each Section, the order that they will be attempted in and any other information for the smooth running of the event.
- TSR33** A person holding a certificate of First Aid competency must be present throughout the duration of the event. The organiser shall be conversant with the nearest Accident/ Emergency services and have the means of contacting them.
- TSR41** It is not permitted to hold an Arena Trials on a Time and Observation basis.

Additionally the following apply:

1. **Referee.** A Referee shall be appointed by the body issuing the permit who must carry out a course inspection prior to the start. The Referee shall replace the Stewards of the Meeting and have the same powers and obligations.

Duties of the Referee

 - a) He shall be in attendance throughout the meeting and for such further period of time as be necessary for him to complete his duties arising therefrom.
 - b) He shall have the duty of enforcing these Regulations.
 - c) He shall prohibit from competing a rider whom, or a motorcycle which, he considers might be a source of danger.
 - d) He shall immediately deal with any appeal that may properly be delivered to him during a meeting.
2. **Permit.** A permit may be issued by a Local Centre for events of up to Centre Restricted, which must comply with the following restrictions:
 - a) The event is not televised other than for local promotional reasons where the transmission must not exceed 5 minutes.
 - b) No Audience participation.
 - c) No involvement of "Fire" in the display,
 - d) No free-style jumping or jumping competition.
 - e) Only controlled riding over obstacles NOT jumping over vehicles or people. f) Estimated audience not to exceed 1,000.

- g) Any “Contractual Terms” must exclude any liability upon the organiser for slipping or tripping in public areas or in Grandstands or in Car Parks.
3. **In all other cases the Permit must be issued by the ACU Office.**
- Spectator safety.** Where no wooden paling or interlinked metal public fence is provided double roping must be erected. The inner rope must be a minimum of 7m from the obstacles and the outer rope must be a distance of 4m from the inner rope.

ACU Normandale Masters Trials Championship

These Championship Regulations to apply in addition to the National Sporting Code, Standing Regulations for Trials and the Supplementary Regulations for each event.

Championship points will be awarded to competitors of any Nationality. The title "ACU Normandale Masters Trials Champion" will be awarded to the competitor with the most points who holds British Citizenship. If a competitor with the most points is not a British Citizen they will be awarded the title "ACU Open Normandale Masters Trials Champion". This principle will apply throughout the Championship classes.

- 1 **Title of Event.** All Supplementary Regulations and Programmes must include the words "Around of the ACU Normandale Masters Trials Series" in the heading and reference to the sponsor, if any, is to be made at the beginning of the regulations.
- 2 **Series Sponsor.** Where there is a Series Sponsor who provides bibs/riding numbers, these must be used by the rider without alteration or the obscuring of Sponsors' logo
- 3 **Qualifying Meetings.** The list of events may be found in the current ACU Fixture List.
- 4 **Eligibility.** Priority of entry at the closing date will be given to Championship points scorers from the current series and the previous year subject to completed entry forms being received by that date. Any entry once accepted by the organiser renders the rider eligible for awards and Championship points.
- 5 Championship Classes

CLASS 1	Over 40 (at the date of the competition)	ROUTE 1
CLASS 2	Over 50 (at the date of the competition)	ROUTE 2
CLASS 3	Over 60 (at the date of the competition)	ROUTE 2
CLASS 4	Air-cooled Monoshocks (no rider age restriction)	ROUTE 2
CLASS 5	Twinshock Class (Must have twin rear suspension units and drum brakes as at the time of manufacture)	ROUTE 2

NB: ROUTE 1 = Standard Route

ROUTE 2= Easier Route

Competitors can only enter ONE Class.

All riders in the same class must ride the same route.

Note Where Sidecars are included in the event it is strongly recommended that separate sections are provided.

The organisers may introduce an additional non Championship class for riders who are not eligible for the Championship classes on Route 1 or Route 2 Priority must be given to Championship entrants if the number of entries is limited.

- 6 **Course** The course shall be on or off road, which must be clearly stated in the Supplementary regulations and be, of no more than 2 laps with a total overall distance of between 5 and 30 miles.
To qualify as a finisher and be eligible for an award, with the exception of a section where the rider has recorded a failure, the rider's machine must have travelled the whole distance under its own power or the exertion of the rider and passenger
- 7 **Observed Sections.** The sections shall be of natural terrain, i.e. no man made materials shall be used, and should be suitable for all classes.
- 8 **Marking.** Marking will be to TSR22 B No stop permitted.
- 9 **Starting Intervals.** All riders must start at one minute intervals.

- All Championship class riders must start consecutively.**
- 10 **Time.** If a time restraint is applied to part of or all of the Trial, it shall be in the form of an individual Time Allowance for each rider and the details given in the Supplementary Regulations or Final Instructions.
- 11 **Championship Points.** Championship points will be awarded to the top 15 eligible finishers in each class at each round on the following scale:
- | | | |
|---------------|---------------|---------------|
| 1st 20 points | 6th 10 points | 11th 5 points |
| 2nd 17 points | 7th 9 points | 12th 4 points |
| 3rd 15 points | 8th 8 points | 13th 3 points |
| 4th 13 points | 9th 7 points | 14th 2 points |
| 5th 11 points | 10th 6 points | 15th 1 point |
- Should a Tie occur it is to be resolved in accordance with TSR23 A)
- Riders who score points in one championship class shall not be eligible for points in another championship class
- 12 **Final Assessment.** At the conclusion of the Series, the points for each rider's best results from all rounds held will be added together and the rider with the highest number of points to his credit will be awarded the relevant Championship title. Should a tie occur it is to be resolved in accordance with TSR23 B)
- 13 **Protests.** Protests to be in accordance with TSR 39.
- 14 **Awards.** The organisers shall supply a minimum of one award to the first placed rider in each class in the event. The first three placings in each class will be presented with certificates at the conclusion of the series whilst the individual class winner will receive an award which will be presented, together with an ACU medal, at the annual ACU Awards Presentation.
- 15 **Jurisdiction.** IN GRANTING A PERMIT TO "PROMOTE" THE COMMITTEE DOES NOT ABROGATE ITS OVERALL RESPONSIBILITY FOR THE CHAMPIONSHIP SERIES AND MAY IN ITS ABSOLUTE DISCRETION, WITHHOLD POINTS FOR ALL OR PART OF A "ROUND" INTRODUCING A REPLACEMENT EVENT AT A LATER DATE IF SEEN FIT.

ACU Wessex plant Hire British Sidecar Trials Championship

These Championship Regulations to apply in addition to the National Sporting Code, Standing Regulations for Trials and the Supplementary Regulations for each event.

Championship points will be awarded to competitors of any Nationality. The title "Wessex Plant Hire ACU British Sidecar Trials Champion" will be awarded to the competitor with the most points who holds British Citizenship. If the competitor with the most points is not a British Citizen, they will be awarded the title of "Wessex Plant Hire British Open Sidecar Trials Champion". This principle will apply throughout the Championship classes.

- 1 **Title of Event.** All Supplementary Regulations and programmes must include the words "Around of the ACU Wessex Plant Hire British Sidecar Trials Championship".
- 2 **Series Sponsor.** Where there is a Series Sponsor who provides bibs/riding numbers, these must be used by the rider without alteration or the obscuring of Sponsors' logo
- 3 **Qualifying meetings.** The list of events will be found in the current ACU Fixture List.
- 4 **Classes.** Class A – British Championship. Class B – ACU Intermediate Championship. Class C – ACU Clubmans Championship. Class D – ACU Newcomer. (A newcomer is classified as a rider who has never competed in the British/ACU Trials Championship on any class of sidecar machine prior to the current year).
The Organiser may at their discretion add a Non Championship Sportsman's class (Class E). The Intermediate Class will ride a 50/50 combination of Championship and Clubmans sections as determined and identified by the Clerk of the Course.
- 5 **Eligibility.** To be eligible for ACU Clubman Championship and ACU Intermediate Championship points, riders must not have won that Championship class in the previous year. Championship class riders may downgrade at the discretion of the Trials and Enduro Committee. Riders not eligible for points (as detailed above) may compete on a no points basis.
The named Driver and Passenger must complete the entire Trial in their respective positions to be eligible for points
- 6 **Entries** Any entry once accepted by the organiser renders the rider eligible for awards and Championship points
Acceptance or Refusal of Entry. The organiser should notify all riders of the position regarding their entry prior to the event.
- 7 **Starting Order.** The organiser shall determine the starting order within each class by ballot. Class C will start first, then Class D, then Class B, then Class A, then Class E. Riding numbers for the Championship class (Class A) will correspond to the rider's finishing position in the previous year.
- 8 **Starting Intervals.** All riders must start at one minute intervals.
- 9 **Method of Marking.** The Championship will be held under TSR22B – Non Stop.
- 10 **Time.** If a time restraint is applied to all or part of a Trial, it shall be in the form of an individual Time Allowance for each rider and the details given in the Supplementary Regulations or Final Instructions.
- 11 **Championship Points.** Championship points for each class will be awarded to the top 15 eligible finishers in each round on the following scale:

1st 20 points	6th 10 points	11th 5 points
2nd 17 points	7th 9 points	12th 4 points
3rd 15 points	8th 8 points	13th 3 points

4th 13 points 9th 7 points 14th 2 points
5th 11 points 10th 6 points 15th 1 point

Should a Tie occur it is to be resolved in accordance with
TSR23(a)

A rider who scores points in one Championship class shall not be eligible for points
in another Championship class.

12 **Protests.** Protests in this Championship must be submitted within 30 minutes of the
announcement of results provided the results are displayed within 30 minutes of the
last rider finishing.

13 **Final Assessment.** At the conclusion of the Series, the points for each rider's performance
in all rounds held will be added together and the rider with the highest number of points
to his credit will be awarded the relevant Championship title.

Should a tie occur it is to be resolved in accordance with TSR23 (b)

14 **Course.** The course shall be between 6 and 30 miles, with a minimum of 36
subsections. No more than 2 laps to achieve minimum mileage. In addition no more
than 10 double sub sections must be used.

To qualify as a finisher and be eligible for an award, with the exception of a section where
the rider has recorded a failure, the rider's machine must have travelled the whole
distance under its own power or the exertion of the rider and passenger.

15 **Observed Sections.** The sections should be of a natural terrain i.e. no man-made
artificial hazards. Sections for the Intermediate Class will be determined by the Clerk
of the Course and identified accordingly.

16 **Awards.** The Organisers shall supply a minimum of one award to the first placed rider
in each class in the event. The first three placings in each class will be presented with
certificates at the conclusion of the series whilst the individual class winners will
receive an award which will be presented together with an ACU medal at the annual
ACU Awards Presentation. Where more than one passenger accompanies the driver in
the series the passenger named on the award shall be the one who rides in the most
rounds. Should a tie still remain then the award will go to the passenger who
accompanies the rider at the last round.

17 **Jurisdiction.** IN GRANTING A PERMIT TO "PROMOTE" THE TRIALS AND ENDURO
COMMITTEE DOES NOT ABROGATE ITS OVERALL RESPONSIBILITY FOR THE
CHAMPIONSHIP SERIES AND MAY IN ITS ABSOLUTE DISCRETION, WITHHOLD
POINTS FOR ALL OR PART OF A "ROUND" INTRODUCING A REPLACEMENT EVENT
AT A LATER DATE IF SEEN FIT.

ACU Belle Trailers British Ladies and Girls Trials Championships

These Championship Regulations to apply in addition to the National Sporting Code, Standing Regulations for Trials and the Supplementary Regulations for each event.

Championship points will be awarded to competitors of any Nationality. The title "ACU Belle Trailers British Ladies and Girls Trials Championships" will be awarded to the competitor with the most points who holds British Citizenship. If the competitor with the most points is not a British Citizen they will be awarded the title "ACU Belle Trailers British Ladies/Girls Open Trials Champion". This principle will apply throughout the Championship classes.

- 1 **Title of Event.** All Supplementary Regulations and Programmes must include the words – "incorporating the ACU Belle Trailers British Ladies And Girls Trials Championships".
- 2 **Series Sponsor.** Where there is a Series Sponsor and the Organiser provides bibs/riding numbers, these must be used by the rider without alteration or the obscuring of sponsors' logo.
- 3 **Eligibility.** All riders in the Championship classes must be of the female gender. Classes for girls are as defined under youth riders in TSR1.
- 4 **Classes**
 Ladies Championship
 Girls A Championship
 Ladies 50/50 Championship
 Ladies Intermediate
 Championship Girls A
 Intermediate Championship Girls
 B Championship
 Girls C Championship
 Girls D Championship
 Ladies Sportsperson (Non
 Championship) Girls Sportsperson (Non
 Championship)
- 5 **Starting.** Starting intervals shall be at intervals of 1 minute.
- 6 **Cut Out Device.** All competitors riding combustion engine machines must have cut out devices rigidly connected to the rider by lanyard (max length 1 metre) so as to stop the engine should the rider and machine be parted.
- 7 **Time Allowed.** There will be an overall individual time allowance for the Trial. The Final Time Control must be located immediately after the final section. The rider is obliged to go directly from the Final Control to the Results Recorder. Any rider who delays the publication of a result will be reported to the Stewards of the Meeting for disciplinary action.
- 8 **Method of Marking.** The Championship will be held under TSR 22B.
- 9 **Course.** The course will be entirely on private land and will consist of a minimum of ten Sections. NB The maximum lap length must be no more than 2 miles (measured accurately) taking into account accessibility for parents who will be on foot
 There will be 3* routes as follows:
 ROUTE 1 Ladies Championship
 Class 50% ROUTE 1 and 50% ROUTE 2 Girls A Championship
 Class
 ROUTE 2 Ladies 50/50 Championship Class
 Ladies Intermediate Championship
 Class Girls A Intermediate
 Championship Class Girls B
 Championship Class
 ROUTE 3 Girls C Championship Class

Girls D Championship Class
Ladies Sportsperson (Non Championship)
Girls Sportsperson (Non Championship)

***Note:** In the Girls D Championship Class a 4th route may be offered at the discretion of the organisers if practical

All routes to be clearly distinguished with appropriate marking, particularly where routes are split.

To qualify as a finisher and be eligible for an award, with the exception of a section where the rider has recorded a failure, the rider's machine must have travelled the whole distance under its own power or the exertion of the rider and passenger.

10 **Assistants.** Each Rider may register one Assistant to accompany them on the course and carry tools. The Assistant must comply with the following:

- The Assistant must be a minimum age of 18 years
- The Assistant must pay a fee.
- The Assistant is NOT allowed to ride a motorcycle.
- The Assistant will only be allowed into the boundaries of a section if their rider is in that section and if specifically invited by an official.
- The Assistant must wear identification supplied by the organiser

The rider and the assistant must sign a declaration that the rider is responsible for all the actions of the assistant. In the case of an injury, a substitute assistant may be registered.

The rider's machine must travel the whole distance of the course under its own power or the exertion of the rider.

N.B. The Organiser must charge an Assistants fee to cover insurance etc and the Assistant must be issued with identification eg. Bib, Armband etc

11 **Championship Points.** Any entry once accepted by the organiser renders the rider eligible for awards and Championship points. Championship points will be awarded to the top 15 eligible riders in each Championship Class at each event on the following scale for each class: 1st 20 points 6th 10 points 11th 5 points

2nd 17 points	7th 9 points	12th 4 points
3rd 15 points	8th 8 points	13th 3 points
4th 13 points	9th 7 points	14th 2 points
5th 11 points	10th 6 points	15th 1 point

Should a Tie occur it is to be resolved in accordance with TSR23(a)

A rider who scores points in one Championship class shall not be eligible for points in another Championship class.

12 **Awards.** The organisers shall supply a minimum of one award to the first placed rider in each class. The first 3 placings in each Ladies class and the first 3 placings in each Girls class will be presented with certificates at the conclusion of the series. The individual Ladies class winners and the first 3 Girls class winners will receive an award which will be presented together with an ACU medal at the Annual ACU Awards Presentation.

13 **Protests.** Protests in this Championship must be submitted within 30 minutes of the announcement of results provided the results are displayed within 30 minutes of the last rider finishing.

14 **Final Assessment.** At the conclusion of the series, the points for each rider's performance from all rounds held will be added together and the rider with the highest number of points to her credit will be awarded the relevant Championship title.

Should a tie occur it is to be resolved in accordance with TSR23 (b)

15 **Jurisdiction.** IN GRANTING A PERMIT TO 'PROMOTE' THE COMMITTEE DOES NOT ABROGATE ITS OVERALL RESPONSIBILITY FOR THE CHAMPIONSHIP SERIES AND MAY IN ITS ABSOLUTE DISCRETION, WITHHOLD POINTS FOR ALL OR PART OF A 'ROUND' INTRODUCING A REPLACEMENT EVENT AT A LATER DATE IF SEEN FIT.

ACU S3 parts National Trials Championship

These Championship Regulations to apply in addition to the National Sporting Code, Standing Regulations for Trials and the Supplementary Regulations for each event.

Championship points will be awarded to competitors of any Nationality. The title "ACU S3 Parts National Trials Champion" will be awarded to the competitor with the most points who holds British Citizenship. If the competitor with the most points is not a British Citizen, they will be awarded the title "ACU S3 Parts National Open Trials Champion". This principle will apply throughout the Championship classes.

- 1 **Title of Event.** All Supplementary Regulations and Programmes must include the words – "incorporating the ACU S3 Parts National Trial Championship". Where possible the sponsor's logo provided must be used.
- 2 **Series Sponsor.** When the Series Sponsor provides bibs/riding numbers, these must be used by the rider without alteration or the obscuring of Sponsors' logo
- 3 **Eligibility.** Any entry once accepted by the organiser renders the rider eligible for awards and Championship points. To be eligible for Championship points, (Classes A and B) the riders must not, in the previous three calendar years, have
 - Finished in the top ten places in the final standings of the British Solo Trials Championship in the previous three calendar years.
 - Won the British Solo Expert Class of the British Solo Trials Championship in the previous three calendar years.
 - Won the S3 Parts ACU National Trials Championship more than once in the previous three years.
 Exceptions may be made at the discretion of the Trials and Enduro Committee.
 PRIORITY OF ENTRY AT THE CLOSING DATE IS TO BE GIVEN TO RIDERS IN THE S3 PARTS CHAMPIONSHIP CLASSES
- 4 **Route 1 (hardest)**
 Class A – All riders eligible for S3 Parts Expert Championship points.
 Class B – Riders eligible for S3 Parts Expert Championship points and riding a machine not exceeding 125cc are also eligible for points in the "125cc S3 Parts Championship.
 Class C – Additional riders not eligible for Championship points (as described above) who wish to ride the Championship route through the sections. Organisers may include a 3rd route of up to 10 sections of higher severity for this class.
Route 2 (Easier)
 Class D – All riders eligible for S3 Parts Clubman Championship points
 Class E – Riders aged 40 and over at the date of the competition
- 5 **Sections.**
 Riders riding Classes A, B and C will ride the principal route through all sections. Riders riding Classes D and E will ride sections with easier variations to at least 50% of the sections
- 6 **Start Order.** Riders will start at one minute intervals
 First round of the series: Riders will start in the following group order: First – All riders in the Clubman Championship.
 Second – All riders entered in the S3 Expert Class.
 Third – All riders who finished in the top 15 of the S3 Expert Class in the previous year who are still eligible for points.

- Fourth – All riders ineligible for points.
Riders will be balloted within their groups except for the top 15 group who will start in reverse order of the previous year's ranking.
For subsequent rounds riders will be grouped as follows:-
First – All riders in the Clubman Championship.
Second – All riders in the S3 Expert Class.
Third – Top 15 points scorers of the current series in reverse order of their current standing.
Fourth – All riders ineligible for points.
Where there are 2 rounds in consecutive days, or on the same weekend the ranking of the top 15 will be based on their positions before the first of the two rounds.
- 7 **Time.** If a time restraint is applied to part of or all of the Trial, it shall be in the form of an individual Time Allowance for each rider and the details given in the Supplementary Regulations or Final Instructions.
- 8 **Championship Points.** Championship points for each class will be awarded to the top 15 eligible finishers in each round on the following scale:
- | | | |
|---------------|---------------|---------------|
| 1st 20 points | 6th 10 points | 11th 5 points |
| 2nd 17 points | 7th 9 points | 12th 4 points |
| 3rd 15 points | 8th 8 points | 13th 3 points |
| 4th 13 points | 9th 7 points | 14th 2 points |
| 5th 11 points | 10th 6 points | 15th 1 point |
- Should a Tie occur it is to be resolved in accordance with TSR23(a)
- 9 **Final Assessment.** At the conclusion of the Series, the points for each rider's best results from all rounds held will be added together and the rider with the highest number of points to his credit will be awarded the relevant Championship title.
Should a tie occur it is to be resolved in accordance with TSR23 (b)
- 10 **Awards.** The organisers shall supply a minimum of three awards to the first placed riders in each class plus an award for the best 125cc award winner. The first three placings in each class will be presented with certificates at the conclusion of the series whilst the individual class winners will receive an award which will be presented together with an ACU medal at the annual ACU Awards Presentation.
- 11 **Special Notes.** Entry Form/Programme. Provision must be made for the declaration of eligibility for this Championship on the entry form and the programme must indicate which riders are eligible to compete.
- 12 **Protests.** Protests in this Championship must be submitted within 30 minutes of the announcement of results provided the results are displayed within 30 minutes of the last rider finishing.
- 13 **Course.** Whilst this is a National Trial, the Championship course must be laid out to a standard suitable for average Clubman riders with less challenging variations for riders in class D as detailed above. The course shall be between 6 and 30 miles, with a minimum of 36 subsections. No more than 2 laps to achieve minimum mileage. In addition no more than 10 double sub sections must be used.
To qualify as a finisher and be eligible for an award, with the exception of a section where the rider has recorded a failure, the rider's machine must have travelled the whole distance under its own power or the exertion of the rider and passenger
- 14 **Method of Marking.** The Championship will be held under TSR22B.
- 15 **Jurisdiction.** IN GRANTING A PERMIT TO "PROMOTE" THE COMMITTEE DOES NOT ABROGATE ITS OVERALL RESPONSIBILITY FOR THE CHAMPIONSHIP SERIES AND MAY IN ITS ABSOLUTE DISCRETION, WITHHOLD POINTS FOR ALL OR PART OF A "ROUND" INTRODUCING A REPLACEMENT EVENT AT A LATER DATE IF SEEN FIT.

ACU Trail Bike Series incorporating the ACU Trail Bike Championship

These Championship Regulations to apply in addition to the National Sporting Code, Standing Regulations for Trials and the Supplementary Regulations for each event.

The ACU will promote a Trail Bike Series which is aimed at riders who want an enjoyable day on and off road on their road legal machine with Observed Sections suitable for such machines. Championship points will be awarded to competitors of any Nationality. The title "ACU Trail Bike Champion" will be awarded to the competitor with the most points who holds British Citizenship. If the competitor with the most number of points is not a British Citizen they will be awarded the title "ACU Open Trail Bike Champion".

- 1 **Title of Event.** All Supplementary Regulations and programmes must include the words "Around of the ACU Trail Bike Championship" and the name of any official series sponsor.
- 2 **Qualifying Meetings.** The list of events may be found in the current ACU Fixture List.
- 3 **Eligibility.** Trail Bike Series Open to machines that are fully legal to use the Public Highway fitted with working lights, Trials Spec Tyres as per TSR8 for championship class. Non championship class must be road legal & tread pattern at discretion of the organisers and as supplementary regulations, and must be silenced to comply with TSR 14.
 - A) Trail Bike Championship. Open to machines that comply with the following in addition to the above:
 1. Wheelbase not less than 1350mm
 2. Minimum 5 litre fuel tank
 3. Minimum seat length 350mm
 Converted Trial Bikes will be excluded from this Class. The organiser, in conjunction with the Trials & Enduro Committee, reserves the right to place machines regarded as ineligible in the appropriate Class, and the rider will therefore not qualify for Championship points.
 - B) Hybrid Trail Class (championship Route eligible but not an official championship 2020). Machines with a minimum seat height of 700mm using trials bike type running gear with larger tank and seat units, Trials Spec Tyres as per TSR8 and must be silenced to comply with TSR 14.
- 4 **Course.** It is recommended that the course should be between 25 and 75 miles in length and include 25 to 40 sub-sections suited to the type of machine and rider entered. It is recommended that tight turns and steep drops be avoided. Organisers have the option to offer a dual route on a maximum of 8 sections – the harder route for the Championship Class and the easier route for all other classes – with the dual routes being clearly marked. A rider shall be given the opportunity to inspect a section before riding it. To qualify as a finisher and be eligible for an award, with the exception of a section where the rider has recorded a failure, the rider's machine must have travelled the whole distance under its own power or the exertion of the rider and passenger
- 5 **Method of Marking.** As per TSR22 B Non Stop.
- 6 **Championship Points.** Any entry once accepted by the organiser renders the rider eligible for awards and Championship points. Championship points will be awarded to the top 15 eligible finishers at each round on the following scale:

1st 20 points	6th 10 points	11th 5 points
	points	
2nd 17 points	7th 9 points	12th 4 points
3rd 15 points	8th 8 points	13th 3 points

4th 13 points 9th 7 points 14th 2 points
5th 11 points 10th 6 points 15th 1 point

Should a Tie occur it is to be resolved in accordance with
TSR23 (a)

- 7 **Final Assessment.** At the conclusion of the Series, the points for each rider's results from all rounds held will be added together and the rider with the highest number of points to his credit will be awarded the relevant Championship title.
Should a tie occur it is to be resolved in accordance with TSR23(b)
- 8 **Protests.** In this Championship must be submitted within 30 minutes of the announcement of results provided the results are displayed within 30 minutes of the last rider finishing.
- 9 **Awards.** The organisers shall supply a minimum of one award to the first placed rider in each class. The first three placings in each class will be presented with certificates at the conclusion of the series whilst the individual class winners will receive an award, which will be presented, together with an ACU medal, at the annual ACU Awards Presentation.
- 10 **Jurisdiction.** IN GRANTING A PERMIT TO "PROMOTE" THE COMMITTEE DOES NOT ABROGATE ITS OVERALL RESPONSIBILITY FOR THE CHAMPIONSHIP SERIES AND MAY, AT ITS ABSOLUTE DISCRETION, WITHHOLD POINTS FOR ALL OR PART OF A "ROUND" INTRODUCING A REPLACEMENT EVENT AT A LATER DATE IF SEEN FIT

ACU Belle Trailers British Solo Youth Trials Championship

These Championship Regulations to apply in addition to the National Sporting Code, Standing Regulations for Trials and the Supplementary Regulations for each event.

Championship points will be awarded to competitors of any Nationality. The title "ACU Belle Trailers British Solo Youth Trials Champion" will be awarded to the competitor with the most points who holds British Citizenship. If the competitor with the most points is not a British Citizen they will be awarded the title "ACU Belle Trailers British Open Solo Youth Trials Champion". This principle will apply throughout the Championship classes.

- 1 **Title of Event** All Supplementary Regulations and Programmes must include the words "ARound of The ACU Belle Trailers British Solo Youth Trials Championship"
- 2 **Series Sponsor.** Where there is a Series Sponsor who provides bibs/riding numbers, these must be used by the rider without alteration or the obscuring of Sponsors' logo.
- 3 **Eligibility.** Open to A, B, C & D Class youth riders as defined under TSR1.
- 4 **Classes.** See TSR 1.
A Class
B Class
C Class Std wheel
C Class Med wheel (Combustion Engine & Electric)
D Class Med wheel (Combustion Engine & Electric)
D Class Small wheel (Combustion Engine & Electric)
- 5 **Routes**
A Class will ride Route 1
B Class will ride Route 2
C Class Standard wheel will ride Route 3
C Class Medium wheel Petrol & Electric combined will ride 50% Route 3 50%
Route 4 (NB where routes are split they must be clearly defined)
D Class Medium wheel Petrol & Electric combined will ride Route 4
D Class Small wheel will ride Route 5
Any rider wishing to ride in a class lower than their age may do so on a no points basis
- 6 **Starting Order.** The riders will have their starting order determined by ballot.
- 7 **Starting Intervals.** All riders will start at one minute intervals, by class
- 8 **Cut Out Device.** All competitors' machines must have cut out devices rigidly connected to the rider by lanyard (max length 1 metre) so as to stop the engine should the rider and machine be parted.
- 9 **Time Allowed.** There will be an overall individual time allowance for the Trial. The Final Time Control must be located immediately after the final section. The rider is obliged to go directly from the Final Control to the Results Recorder. Any rider who delays the publication of a result will be reported to the Stewards of the Meeting for disciplinary action.
- 10 **Assistants.** Each Rider may register one Assistant to accompany them on the course and carry tools. The Assistant must comply with the following:
 - The Assistant must be a minimum age of 18 years
 - The Assistant must pay a fee.
 - The Assistant is NOT allowed to ride a motorcycle.
 - The Assistant will only be allowed into the boundaries of a section if their rider is in that section and if specifically invited by an official.

- The Assistant must wear identification supplied by the organiser
- The rider and the assistant must sign a declaration that the rider is responsible for all the actions of the assistant. In the case of an injury, a substitute assistant may be registered.

The rider's machine must travel the whole distance of the course under its own power or the exertion of the rider.

N.B. The Organiser must charge an Assistants fee to cover insurance etc and the Assistant must be issued with identification eg. Bib, Armband etc.

- 11 **Championship Points** Any entry once accepted by the organiser renders the rider eligible for awards and Championship points. Championship points will be awarded to the top 15 eligible finishers in each class at each round on the following scale: A rider can only gain Championship points from one class in one year.

1st 20 points	6th 10 points	11th 5 points
2nd 17 points	7th 9 points	12th 4 points
3rd 15 points	8th 8 points	13th 3 points
4th 13 points	9th 7 points	14th 2 points
5th 11 points	10th 6 points	15th 1 point

Should a Tie occur it is to be resolved in accordance with TSR23 (a)

Riders who score points in one championship class shall not be eligible for points in another championship class.

- 12 **Awards.** The organisers shall supply a minimum of one award to the first three placed riders in each class. Each class will be presented with certificates at the conclusion of the series and an award which will be presented, together with an ACU medal, at the annual ACU Awards Presentation.

- 13 **Protests.** Protests in this Championship must be submitted within 30 minutes of the announcement of results, provided the results are displayed within 30 minutes of the last rider finishing.

- 14 **Final Assessment.** At the conclusion of the series, the points for each rider's performance from all rounds held will be added together and the rider with the highest number of points to his credit will be the winner.

Should a tie occur it is to be resolved in accordance with TSR23 (b)

- 15 **Observed Sections.** Each observed section or subsection must be attempted in the order in which they are numbered, except where a class is instructed to start other than at Section 1, they must still attempt the sections consecutively. The sections should be of natural terrain, i.e. no man-made hazards and consecutively numbered.

- 16 **Method of Marking.** As per TSR 22B.

- 17 **Assistance on the Course** The rider may receive assistance to repair their machine anywhere on the course. The rider's machine must travel the whole distance of the course under its own power or the exertion of the rider.

- 18 **Course.** The number of laps and approximate length of lap must be stated in the Supplementary Regulations. NB The maximum lap length must be no more than 2 miles (measured accurately) taking into account accessibility for parents who will be on foot.

To qualify as a finisher and be eligible for an award, with the exception of a section where the rider has recorded a failure, the rider's machine must have travelled the whole distance under its own power or the exertion of the rider and passenger

- 19 **Riding Bibs.** If bibs are supplied they must be worn by competitors throughout the event without any defacement.

- 20 **Jurisdiction.** IN GRANTING A PERMIT TO 'PROMOTE' THE COMMITTEE DOES NOT ABROGATE ITS OVERALL RESPONSIBILITY FOR THE CHAMPIONSHIP SERIES AND MAY IN ITS ABSOLUTE DISCRETION, WITH-HOLD POINTS FOR ALL OR PART OF A 'ROUND' INTRODUCING A REPLACEMENT EVENT AT A LATER DATE IF SEEN FIT.

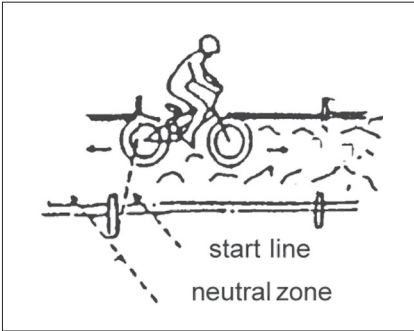

Fig 1

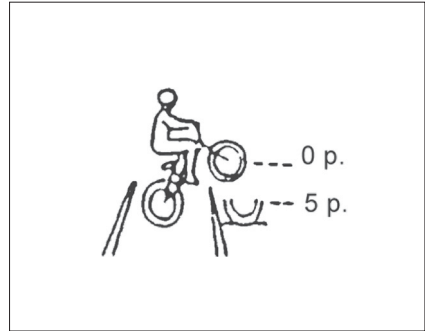

Fig 2

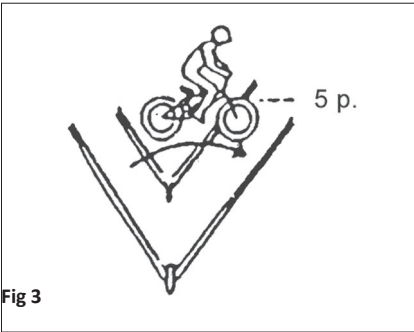

Fig 3

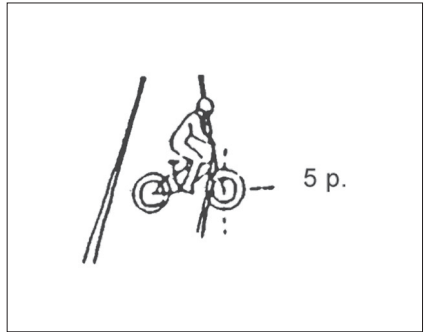

Fig 4

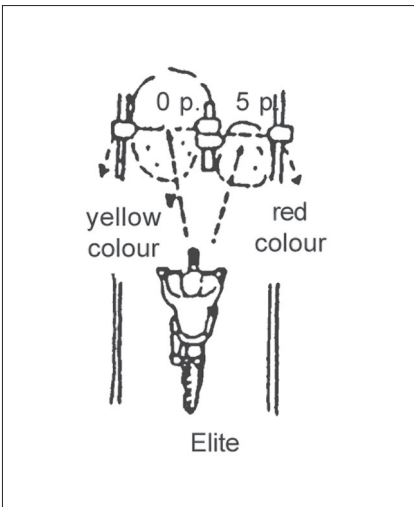

Fig 5

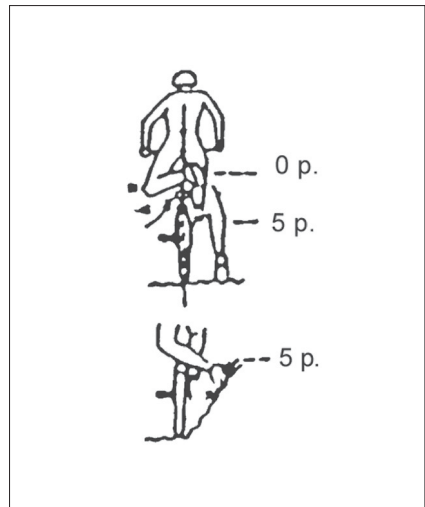

Fig 6

Track Racing

Standing Regulations

SECTION 1 GENERAL	205
SECTION 2 PROCEDURES	207
SECTION 3 RIDERS	213
SECTION 4 TECHNICAL	215
SECTION 5 SAND/BEACH RACING	224
SECTION 6 FLAT TRACK	225
SECTION 7 FLAT TRACK TECHNICAL REGULATIONS	225
SECTION 8 1000CC SIDECAR SPEEDWAY REGULATIONS	225
SECTION 9 YOUTH COMPETITOR REGULATIONS	228
SECTION 10 GRASS TRACK EVENTS HELD ON SPEEDWAY CIRCUITS	230
SECTION 11 TRACK RACING OFFICIALS	231

The Sporting Code and the Standing Regulations of the ACU together with the Supplementary Regulations will apply to all Grass Track Races.

SECTION 1 GENERAL

1.1 COMPLIANCE WITH REGULATIONS

Every rider (and parent/guardian for youth) entering or being entered acknowledges that he/she is bound by the ACU Sporting Code, these Track Racing Regulations, together with any Supplementary Regulations and Final Instructions thereafter issued to all of which they undertake to submit and moreover, renounce the right to have recourse to any arbitration or tribunal not provided for in the rules.

1.2 ELIGIBILITY

For National competitions, entrants, drivers and passengers must hold a current competition licence for International or National events issued by the ACU, or the Scottish ACU. Organisers may allow licence holders from FMNs within FIM Europe to participate. Start permission from the relevant FMN must be submitted to the organiser and any additional third party insurance must be obtained. For all competitions of below National status, a current competition licence of the appropriate grade is required. Details of eligibility will be found in the Supplementary Regulations of the event.

Applicants for youth licences please refer to the Youth Licence Regulations within this handbook. The minimum age for an adult competitor is 16 years, but applications will be considered by the Track Racing Committee (TRC) for 15 year olds to ride in the 250cc class. The minimum age for 1000cc Sidecar drivers and passengers is 17 years. The minimum age for 500cc Right Hand Sidecar class is 15 years old for both drivers and passengers.

Any competitor over 70 years of age must have a medical examination.

1.3 NON-STARTERS/RESERVES/SUBSTITUTES

The place of any non-starter shall be taken by a RESERVE driver whose entry has been accepted, and in the order of priority as listed in the official programme of the competition. A SUBSTITUTE driver may be nominated only by the ENTRANT being the holder of an Entrant's International or National competition licence. Where a rider is his own entrant, no substitution will be permitted (see Sporting Code). A change of passenger during a meeting is permitted if authorised by the Clerk of the Course and having completed a minimum of two laps practice within that class.

1.4 ALTERATIONS TO PROGRAMME

In the event of a race being cancelled due to insufficient entries, the organisers reserve the right to offer the race time and prizes for a race of similar length, for machines of another class or category.

1.5 ABANDONMENT

The organisers reserve the right, subject to the approval of the Stewards of the Meeting, to cancel, postpone or abandon any event, or the competition itself, if circumstances should arise which in their opinion, renders such action necessary.

1.6 BRITISH INDIVIDUAL GRASS TRACK CHAMPIONSHIPS

It is a condition of the issue of a National competition licence that the competitors will not be granted authority to compete at home or overseas at any event which clashes with the qualifying rounds or the Final of an Individual Championship for which they have qualified or may be nominated for.

Competitors should also note the requirements for International selection through the appropriate Individual Championship. However, following a written request to the TRC, permission may be given for a rider to compete at a FIM EUROPE or FIM Championship event which conflicts with the date of an Individual Championship event within the UK.

1.7 ADULT TRACK RACE RECORDINGS

At all ACU Grass Track events, points will be allocated to competitors finishing in point scoring positions. Standings in the National Grading lists will be used to decide competitors for the 250cc and 350cc Solo, 500cc Sidecar and 1000cc Left Hand Sidecar British Championships. The British Masters Qualifier Championship will not be awarded grading points. For all Grass Track events, the following points will be awarded in each class:

1st = 6 points

2nd = 5

points 3rd =

4 points 4th =

3 points 5th =

2 points 6th =

1 point.

Points are allocated on the results of each class at each event. In classes where there is more than one Final, points will only be allocated on the results of the first Final.

Where a competitor rides in more than one class, they will score points for each class. These points are not transferrable between classes.

Points will not be allocated in an 'Unlimited' capacity or 'Open' classes, with exception of 'Upright' Solos and 'Pre 75' Solo classes. In these classes, 'Unlimited' and '500cc' results will be combined. There will be no Grading List for 250cc or 350cc Upright or Pre 75 classes.

Results are declared by the Clerk of the Course. They are either decided by a one-race Final, or by point-scoring legs.

The conditions of results must be listed in the race programme. In the result of a tie, it is at the organising Club's discretion how ties are decided.

Points will only be awarded if results are declared after no less than two heats per competitor. All National Grading lists will be published online throughout the season.

At the end of the season, results will be compiled, checked and cross-referenced with the Centre Recorders to ascertain the final standings.

1.8 YOUTH TRACK RACING RECORDINGS

At all ACU Youth Grass Track events, points will be allocated to competitors in accordance with their finishing positions.

Points will be used to form the National Grading list for these four Youth classes: (a) Auto-Cadet, (b) Cadet, (c) Juniors and (d) Inters.

Competitors who ride in more than one class will score points for each class, but points are not transferrable between classes.

All Youth competitors riding in an event will score points. However, competitors must complete in least one race to earn National grading points.

Points are allocated based on the number of competitors in the event. For example, when 5 riders compete, points will be allocated as follows:

1st = 5 points

2nd = 4

points 3rd =

3 points 4th =

2 points 5th =

1 point.

1.9 CLERK OF THE COURSE

A list of current National ACU Clerks of the Course is available from the ACU Head Office.

1.10 CONDUCT

All ACU licence holders are expected to conduct themselves in a professional manner. Any physical/

verbal abuse directed towards Officials of the Meeting will be subject to disciplinary action in accordance with NSC chapter 10/11.

SECTION 2 PROCEDURES

2.1 DIRECTION OF RACING

Solos A, 500cc Sidecar B1(c), 1000cc B1 (b), will race in an anti-clockwise direction. 1000cc Sidecar B1 (a) will race in a clockwise direction.

2.2 RUNNING OF ENGINES

The running of engines is prohibited except during official practicing and actual racing, and for a period not exceeding fifteen minutes prior to the start of official practice and five minutes prior to the start of each race. A breach of this regulation will involve disqualification from the meeting of the driver (and passenger where applicable) of the motorcycle concerned.

Engines must NOT be warmed up prior to Technical Inspection

2.3 CONTROL OF EXHAUST SOUND LEVEL

The Clerk of the Course may exclude any machine which exceeds the maximum permitted sound level, or which in his opinion is deemed to be excessively noisy. The sound level will be controlled either by the fitment of an FIM homologated silencer or, in the absence of homologated silencers according to the FIM 2 Metre Max Method where the sound levels will not exceed 81dB(A) when measured at a distance of 100 metres. For precise method of testing, please refer to the Sound Control Regulations within this Handbook. Random or spot checks may be made by ACU Sound Control Officials of the sound level of any machine not fitted with an FIM homologated silencer taking part in any ACU meeting in addition to any routine checks at Technical Control. Exhaust heatshields are recommended but not mandatory with the exception of the 500cc Sidecar class.

2.4 ENGINES MEASUREMENT

Where it becomes necessary for the ACU or an organiser to verify any fact relating to an engine capacity, it shall be carried out at the cost of the rider. Where an engine is measured, as the result of a protest, the protest must be submitted with the appropriate fee plus a deposit of £250.00 for a single cylinder engine and £500.00 for a multi-cylinder engine which can only be returned if the protest is upheld. If the protest is unsuccessful then the deposit will be awarded to the person against whom the protest has been made and the protest fee will be sent to the ACU Benevolent Fund. The Clerk of the Course shall judge as guilty anyone who refuses to present an engine for measurement. The rider (and passenger where applicable) will be excluded from the results of the event and will be subject to disciplinary procedures. If engines are presented for measurement, but this cannot be carried out at the event, the engines must be sealed for later measurement. If seals are damaged or removed the rider will be excluded from the results and fined. A sealed engine must be measured before the next round of that championship for which it has qualified, or within 28 days, whichever is the sooner.

2.5 ENVIRONMENTAL PROTECTION

- a) Environmental mats must be used by all competitors for every machine present at an event, practice or training, to prevent the discharge of fuel, oil, cleaning fluids, degreasants, cooling and brake fluids from contaminating the ground. This includes all areas within the confines of the event including pits, warm up areas and Parc Ferme. If competitors provide their own personal generator(s), then these must also be positioned on a suitably sized environmental mat.
- b) The power washing of motorcycles is not permitted at Grass Track events.
- c) Competitors and their teams must make use of the containers provided by the organiser for the disposal of oils and other waste material.

- d) Organisers must ensure that any waste oil collection points are positioned within suitable bunds.
- e) The minimum technical data for an environmental mat is: Solo Machines: minimum 160cm × 100cm
Sidecar: minimum 160cm × 200cm.
- f) The ACU Environmental Code must be respected at all times.

2.6 TECHNICAL CONTROL

All motorcycles and protective clothing must be presented to the Technical Official for examination before the start of any practice, or at any time during the meeting as may be required by the Clerk of the Course or Senior Technical Official, to ensure continued compliance with the requirements of the regulations. Spokes on all wheels must be accessible during technical control. Any machine involved in an accident must be presented to Technical Control for re-inspection before being ridden again at the meeting. Youth – protective clothing must be worn by competitors when presented for Technical Control. Engines should be cold when submitted for technical inspection.

2.7.1 PRACTISING

At all Grass Track meetings controlled practicing will be allowed on the course and each driver and passenger must complete at least two laps of practice to qualify for the event. Practice laps must be recorded.

Solo: Youth & GT140cc should be run as separate practice sessions.

2.7.2 PRACTICE STARTS

Practice starts are permitted provided they take place off the “racing line”, unless stated otherwise in the Supplementary Regulations for the event.

2.8 ON TRACK STARTS

The Start/Finish line should be positioned at 50% of the length of the straight. No more than eight Solos, six Sidecars or six quads machines are permitted at the start line.

The inner stanchion (post) of the ‘On Track’ start gate should be positioned approximately one metre from the inner edge of the track, and should be covered with either straw bales or other suitable cushioning material – at least 60cm in width and two metres in height, towards the direction of racing. The outer stanchion of the start gate should be positioned on the spectator side of the first catch fence and must be protected by straw bales or other suitable cushioning material.

Youth events: ‘On Track’ starting gates ARE NOT permitted at any youth only event. If a combined youth and adult event is being staged, then the organising club must supply an ‘Off Track’ starting gate for the youth competitors.

2.9 METHOD OF STARTING

The method of starting shall be stated in the Supplementary Regulations. Any rider whose machine touches the starting tapes once under starter’s orders will be disqualified. For National adult events a green light will be illuminated to indicate to riders that they are under Starter’s Orders.

2.10 STARTER’S ORDERS

Only scheduled riders/passengers in the starting area or on a grid will be deemed to be under Starter’s Orders, except Auto Cadet/Cadet Youth classes. No other rider is subsequently permitted to start in a race. Machines must not move whilst under starter’s orders.

2.11 DELAYING THE START

Any rider not prepared to start within two minutes after being called from the pit box will be disqualified from the race.

2.12 FALSE START

Any rider who in the opinion of the Clerk of the Course has caused a false start will be disqualified from that race.

2.13 FLAG SIGNALS

The following code of flag signals will be used where appropriate.

National flag: Start.

Yellow: Accident, slow down, driver must be prepared to stop. OVERTAKING STRICTLY PROHIBITED. Any rider judged to have taken unfair advantage by racing or attempting to overtake within the area controlled by the yellow flags will be considered guilty of unfair and/or dangerous driving and will be disqualified.

Red: Immediate STOP all drivers – return to the pits at a walking pace or as directed by the Marshals.

Green: Course clear.

Yellow with Black diagonal cross: Start of last lap.

Chequered Black and White: Finish.

Any additional flag signals will be stated in the Supplementary Regulations. Only authorised Officials are permitted to use these flags.

All the above flags should measure not less than 750mm × 600mm.

2.14 FINISH OF RACE

The chequered flag will be displayed as the winner crosses the finishing line and will be displayed until the last rider finishes the lap. No rider will be allowed to start a new lap after the chequered flag has been displayed. Thereafter riders crossing the line will be flagged off, their position being determined by the number of laps each has completed. To be classified as a finisher a rider must complete $\frac{3}{4}$ of a four lap race or $\frac{2}{3}$ of a six lap race within three minutes of the winner crossing the finish line.

A competitor who has started in a Final but not completed race distance will be placed according to the number of laps completed, without the requirement to complete a minimum number of laps.

2.15 FALSE FINISHES

When a race has been indicated as finished by the display of the chequered flag before the required number of laps has been completed by the leading rider, the race must be declared null and void and re-run unless the leading rider had completed 75% of the scheduled number of laps, in which case the result will stand.

If the chequered flag has not been shown after the completion of the scheduled number of laps, the chequered flag shall be considered to have been shown at the completion of the scheduled number of laps.

2.16 STOPPING A RACE

- a) If an incident occurred on the race start straight or the first corner, which the Clerk of the Course determines will unfairly affect the outcome of the race he may, at his sole discretion, declare an unsatisfactory start, stop the race and allow all riders back into the re-run.
- b) If an accident has occurred and in the opinion of the Clerk of the Course it would be dangerous for the race to continue, he will order the race to be stopped and may order it to be re-run. The Clerk of the Course will exclude the rider(s) who he deems to be the primary cause of the race being stopped.

2.17 STOPPAGE OF A RACE

If a race is stopped before the race leader has completed $\frac{3}{4}$ of a four lap race, or $\frac{2}{3}$ of a three or six lap race, the race shall be re-run. If the race leader has completed the above race distances, ($\frac{3}{4}$ of four lap race or $\frac{2}{3}$ of a three or six lap race), before the race is stopped, the results can be declared at the discretion of the Clerk of the Course.

2.18 RE-RUN RACES

In the event of a race being re-run, the Clerk of the Course may permit any rider who has fallen either as a result of his having been fouled or because he had deliberately 'laid down' his motorcycle or has left the course in the interest of safety, to take part in the re-run. Any rider having been the primary cause of the stoppage, or not proceeding under mechanical power at the time of the stoppage, will not be eligible to take part in the re-run.

2.19 LEAVING THE COURSE/CUTTING THE COURSE

Any competitor(s) whose motorcycle crosses the defined edges of the track markers/white line – with any wheel – will be disqualified unless, in the opinion of the Clerk of the Course, the action was taken in the interest of safety for other competitors, or the competitor involved was forced 'off course' due to the actions of another competitor.

2.20 RIDING IN THE PITS

The riding of motorcycles in the designated pit area is strictly prohibited. Where possible an area protected by a safety fence shall be provided for competitors to start their motorcycles.

2.21 RIDERS PRESENTATION LAP/WINNERS LAP OF HONOUR

No unauthorised passengers (children, wives/partners etc.) are allowed to ride on a competitor's motorcycle at any time during the event. In exceptional circumstances, an organiser may apply to the TRC for dispensation to this rule.

2.22 OUTSIDE ASSISTANCE

If, during a race, a rider receives outside assistance, other than that provided by the organisers for the removal of himself or his machine from the course in the interests of safety, he will be excluded.

2.23 FOUL, UNFAIR OR DANGEROUS RIDING

The Clerk of the Course may discipline any rider who, in his opinion is guilty of unfair, foul or dangerous riding in accordance with 10.03.3.3 of the National Sporting Code of the ACU.

2.24 CHANGE OF MACHINE OR PASSENGER

A change of machine and/or passenger within a particular capacity class may be permitted at any stage of an event (including the re-run of any races) subject to the approval of the Clerk of the Course, providing that:

- a) The machine has been passed by the Technical Official.
- b) The passenger has an appropriate licence, has signed on, and has taken part in the Sidecar practice.

2.25 TIES

(Required for ACU Championship and National events, recommended for other events – if an alternative method is to be used, it must be included in Supplementary Regulations)

Intermediate/Semi Final Standings

- a. Count back
- b. Best position in the last heat that the riders met
- c. A ballot in the presence of a Steward

Finals where points are carried forward

- a. Where riders tie on points after the Final, the best place in that Final will decide the overall result.

2.26 MEDICAL CODE OF PRACTICE

Track Racing is potentially dangerous; therefore care regarding the quality of medical facilities,

medical personnel and the fitness of riders is necessary, hence this Code sets out the minimum requirements necessary.

Note: Local hospital authorities must be advised prior to the event of the time and date of the meeting.

The Competitors

Every competitor taking part in a Grass Track event must be medically fit, not under the influence of alcohol or prohibited drugs, and certifies this at the time of Signing-On at a meeting or permitted training session. Competitors, having signed-on, may be required to undergo a medical examination to confirm both their physical and mental fitness. A failure or refusal to undergo an examination will result in immediate disqualification from the meeting or permitted training session.

Where a competitor is withdrawn from a meeting due to injury, all instructions given by the Medical Officer should be noted and adhered to.

Concussion/suspected concussion

If a competitor is involved in an incident which results in him/her being diagnosed by the Medical Officer/Paramedic as suffering from concussion or suspected concussion, the competitor is not permitted to participate any further in that event.

Organisers are to notify ACU Head Office as soon as possible of any concussion/suspected concussion injuries and then will subsequently:

- a) Place the competitor on the ACU Stop List
- b) Inform organisers of forthcoming events that the competitor has suffered a concussion or suspected concussion injury and is therefore placed on the ACU Stop List
- c) Inform the competitor that s/he needs to see a Doctor and obtain a letter/Doctor's certificate which confirms s/he is fit to resume competitive racing/participate in a practice/test session.

The recovery time for anyone diagnosed with concussion or suspected concussion is as follows:

- a) Over 20 years: Excluded immediately and suspended for a period of nine days.
- b) 16–19 years: Excluded immediately and suspended for a period of twelve days.
- c) 15 and under: Excluded immediately and suspended for a period of twenty three days.

The competitor is not permitted to ride during the obligatory suspended periods outlined above and then only once s/he is in possession of a Doctor's certificate/letter after the suspended period has expired.

If a competitor has been injured on a Saturday and is suffering from concussion or suspected concussion, and the organiser is aware that the competitor was intending to ride or is scheduled to ride somewhere else the next day, the organiser will inform the organiser of the event being held the next day so they are aware of the competitor's injuries and as such s/he is prevented from participating in that event.

Facilities

The minimum personnel and facilities required at ALL Grass Track events (below National status) are:

- a) One qualified Medical Officer (MO) e.g. a Doctor, OR a Paramedic (PM) OR an IHCD Emergency Technician (EMT) who must be in attendance during both official practice and racing
- b) One Ambulance with a driver and attendant,
- c) One Medical Treatment Facility
- d) Four qualified First Aid personnel complete with full First Aid equipment, including a stretcher. A second ambulance is strongly recommended but if not, as a minimum, an auxiliary vehicle with a stretcher must also be available on the course during both official practicing and racing.

For events of NATIONAL status and above arrangements must also be made for TWO Doctors or TWO Paramedics, with appropriate equipment for racing, to be in attendance during official practice and racing with TWO (class C) ambulances being available.

For further details, please refer to Medical Services on page 93.

The Medical Officer

The Medical Officer can be either a Doctor or a Paramedic. Nevertheless where a Doctor is present,

s/he will be the Chief Medical Officer, and in the case of two or more Paramedics being in attendance, the one that signs the Injury Report Form assumes the role of Chief Medical Officer. A Doctor must have Medical Malpractice Cover appropriate for pre-hospital immediate care, (NHS Crown Indemnity is not applicable) and must not be subject to working in a GMC Approved Practice Setting (APS).

A Paramedic must hold appropriate Personal Medical Malpractice Insurance cover.

All Paramedics must be registered with the Health Professional Council. Names of Paramedics should be obtained by an organiser prior to the event taking place and then checked on the following HPC website: <http://www.hcpc-uk.org>.

The Chief Medical Officer's responsibilities under these Regulations are to:

- a) Carry out medical examinations of any competitor when specifically requested to do so by the Meeting Steward and or Clerk of Course and in all cases following a track incident.
- b) Complete the appropriate documents as required under ACU Regulations.
- c) Ensure a full complement of personnel and equipment as detailed in these Regulations is available at all times during the Meeting, signing the Injury Report Form to confirm the fact and also that all personnel and equipment conforms to the ACU and other legal requirements.
- d) Ensure adequate arrangements have been made and are maintained for dealing with any casualties and be quickly accessible to the Clerk of Course and be readily available to deal with all medical emergencies.
- e) Inform the Clerk of Course if at any time during the meeting any of the medical requirements are not being met.
- f) Order that racing and/or training be suspended, when insufficient medical cover is available (e.g. following an accident or when the Ambulance, any of the required items of equipment, medical gasses or drugs etc. is not available).
- g) Ensure the availability of and administer any Prescription Only Medicines (POM) or Controlled Drugs (CD) that are appropriate. NB. A Paramedic who has access to drugs on licence from his employing authority may also administer them in accordance with his employing authority's protocols.
- h) Have available resuscitation drugs conforming to Resuscitation Council guidelines and a supply of parenteral and oral analgesics
- i) Ensure that the medical team and First Aiders are familiar with ALL varieties of clothing and equipment worn by competitors/passengers and in the safe procedures for their removal.

Medical Treatment Facility

The Medical Treatment facility may be a second fully equipped Ambulance or a designated Medical Room/tent, with good access, that is well lit, dry, windproof and heated with curtains or similar at all windows, has a chair/couch or similar, a supply of basic medical equipment and facilities for hand washing with hot and cold water. NB. If this is a second Ambulance, appropriately qualified persons must be available to supervise a casualty.

Doctors, Paramedics and First Aid personnel must be in attendance 30 minutes prior to the official practice or start time (whichever is the earliest), wearing appropriate outer clothing that clearly shows their professional designation (front and back) and have personal malpractice indemnity insurance cover or similar provided by their governing body or employing authority (excludes NHS Crown Indemnity).

All members of the medical team (one of whom must have a mobile telephone in working order) must be immediately available to and under the direct control of the event's Chief Medical Officer, who has overall responsibility for all medical and First Aid matters.

Ambulances

Ambulances must be legally road-worthy, taxed, insured and registered as an ambulance with UK DVLA and where applicable, with the Care Quality Commission. The primary ambulance at a meeting must be appropriate for and insured for emergency casualty transportation, have radio communications together with visible and audio signals. It should be equipped as a resuscitation

centre and carry two stretchers; one of which must be an ambulance cot (the second can be a scoop type or similar). Ambulances must incorporate an oxygen supply system that can deliver oxygen at the rate of 10+litres/minute for 60+ minutes, a portable oxygen supply system that can deliver oxygen at the rate of 10+litres/minute for 20+ minutes with oxygen therapy masks capable of delivering high concentrations of oxygen.

Apparatus for:

- a) Automatic or manual ventilation, suction, and intravenous infusion (plus infusion fluids),
- b) Equipment to immobilise limbs and vertebral column
- c) Equipment and fluids for irrigation and toilet of eyes and wounds
- d) First Aid medicaments and materials
- e) ECG Monitor, defibrillator, stethoscope
- f) Inhalational analgesia (nitrous oxide/oxygen mixture) and equipment for its administration
- g) Instruments for haemostasis, equipment for dealing with burns
- h) Apparatus for securing an emergency surgical airway (e.g. cricothyroidotomy)
- i) Equipment for thoracic drainage/de-compression
- j) Sphygmomanometer
- k) Equipment to remove clothing and helmets
- l) Ice or other appropriate means for cooling injuries

The crew of the primary ambulance must consist of a driver, trained and qualified to drive under blue light response conditions and be accompanied by a competent attendant who is capable of giving emergency treatment, both of whom should remain with the vehicle at all times when the ambulance is utilised.

For definitions of Doctor, Paramedic, Ambulance and First Aid personnel please refer to the Medical Services section within this Handbook. Paramedics must be registered with the Health Professional Council.

Note: Be aware that some Paramedics and St Johns Ambulance teams may not be able to carry morphine

2.27 DOGS/pETS

Whilst dogs and other pets are not discouraged from attending Off Road motorcycle sport events, they are to be kept on a lead and under control at all times. Owners are responsible for ensuring that any dog is kept under control and are responsible for clearing up any fouling that may occur.

2.28 RIGHTS OF pROTEST

No protest can be accepted against decisions made by the Clerk of Course or referee where appointed, Chief Technical Steward against matters that are considered a Statement of Fact. Specifically these include:

A ruling on a heat result

A ruling on a racing incident (such as articles 2.11, 2.122, 2.16, 2.21, 2.22, 2.23) A ruling on a Technical Matter

At all meetings a separate, private enclosed area is to be provided away from the public area in order to deal with any protests that may arise.

SECTION 3 RIDERS

3.1 HELMETS

Helmets approved by the ACU bearing the current ACU approval stamp and being in sound condition and properly fitted must be worn by all riders and passengers while practicing and racing. Overseas competitors may use helmets as approved by their own FMN or FIM. Cameras mounted on helmets will not be permitted to be used in Track Racing. For further information regarding helmets please refer to the Helmet section of this handbook.

3.2 PROTECTIVE CLOTHING

In all races and official practice outer clothing made of leather or a substitute, substantially padded at the shoulders, elbows, hips and knees, and leather or suitable substitute material gloves, must be worn by both riders and passengers. Racing suits should be one piece or effectively joined when worn to form one piece. Any other racing suits must meet the standards required for leathers. Where non-leather materials are used they should have the following characteristics equivalent to leather:

- i) Fire retardant ability
- ii) Resistance to abrasion
- iii) Coefficient of friction against track surfaces
- iv) Perspiration absorbing ability
- v) Be nontoxic and non-allergic
- vi) Fabric must not melt

The clothing manufacturer is responsible for ensuring that the products and materials that carry his name conform to these rules. Kevlar suits are approved ONLY if worn with padding or a padded under suit. This under suit can be either one or two piece. Motocross race wear (e.g. separate top/ shirt and trousers) is permitted as long as suitable body armour or a protective under suit is worn. The body armour or under suit must offer suitable protection against abrasion to the body, with padding provided to protect the shoulders, elbows, hips and knees.

Footwear: The minimum requirements for protective footwear for riders is calf length boots and for passengers leather ankle boots (minimum height 200mm).

Goggles: Goggles, and spectacles if worn, shall be of a non-shatter proof material.

Rigid 'Tear Offs' must have rounded corners to avoid causing injury to others when discarded.

Back Protectors: competitors in all classes are required to wear commercially manufactured back protection during both practice and racing.

Youth Protective clothing requirements:

Youth protective clothing should comply to the same standards as those required for adults including the wearing of back protectors.

3.3 JEWELLERY

Competitors are advised not to wear hand, face or body jewellery/piercings which could prove hazardous in the event of an accident. The mouth should be kept clear of anything likely to cause a blockage of the airway in the event of an incident, e.g. chewing gum. This includes removing dentures.

3.4 FIRE EXTINGUISHERS

All competitors must have a 2kg (minimum) dry powder fire extinguisher available for immediate use. If a 'closed vehicle' is being used the extinguisher must be fitted adjacent to, or on the inside of the working door. In the case of a shared vehicle the other competitor's extinguisher(s) should also be visible, or, the fitted extinguisher(s) must be of a proportionately larger capacity.

3.5 LICENCES

- a) **FIM and FIM EUROPE Championship Licences** – the Track Racing Committee will confirm the competitors who qualified and are eligible for these licences. The holders will be automatically entitled to hold an International Non-Championship Licence.
- b) **International Non-Championship Licence** – to qualify for an FIM Non Championship licence, a competitor must finish in the top twenty (Solo) or top ten (Sidecar) in the appropriate British Masters or National Championship. The FIM Non Championship licence is valid for a period of **two years** commencing on the 1st January following the date of qualification. The Track Racing Committee reserve the right to issue this licence to competitors in exceptional circumstances.
- c) **Licence Upgrading** – to upgrade to a National licence, competitors must obtain signatures from the relevant Clerk of the Course to demonstrate that they have finished in SIX final at

lower level events. Sidecar drivers and passengers wishing to upgrade to a National licence must obtain signatures from the relevant Clerk of the Course to demonstrate they have finished in six finals at lower level events in the same category that they are seeking a National licence for.

- d) **Lapsed Licences** – any competitor wishing to renew a licence which requires qualification and the licence has been expired for more than THREE years will be issued with a Restricted licence.

SECTION 4 TECHNICAL

Each rider is responsible for ensuring that his motorcycle conforms to the Technical Regulations.

Refusal to allow the examination of the motorcycle or any parts of the motorcycle by the appointed Technical Steward at any time during the meeting, and for 30 minutes after the Final race, shall be deemed to be an offence which will be reported to the Clerk of the Course and may result in the disqualification of the rider and machine from the race or meeting.

4.1 SPECIFICATION OF MOTORCYCLE

Motorcycles of Solo Category 1, Group A1, Sidecar Category 1, Group B1 (a, b, c) must comply with the following discipline requirements in addition to those of the National Sporting Code Appendix

D. Machines originally designed for Enduro, Motocross, and Trials competitions (as defined in the respective regulations) are permitted in race meetings but may not be used in the same races as Track Racing motorcycles, but may be included on the same permit.

4.2 BRAKES

Motorcycles in Category A(1) and A(2) (Solos) must comply with the following:

- 140cc, 250cc, 350cc and 500cc Track Racing motorcycles used in adult competitions must not be fitted with brakes or decompressors.
- All other motorcycles used in adult competitions to be fitted with at least one effective brake. Motorcycles in Category 1 Group B (a, b) must be equipped with at least one effective brake operating on the motorcycle wheels.

Motorcycles in Category B1(C)

- Brakes are not permitted on 500cc Sidecar motorcycles.

For Youth competitions, all machines must be fitted with an effective brake, with the exception, machines used in the International 125cc and 250cc four stroke class competitions where brakes are not allowed.

Machines without brakes CANNOT COMPETE in the same races as machines with brakes.

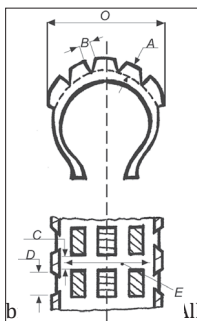

4.3 TYRES

Except for the prohibited use of tractor pattern tread tyres there is no restriction as to the type of tyres which may be used for Solo motorcycles, other than as may be laid down in the Supplementary Regulations. The tread depth and spacing of tyres fitted to the driven wheel of Groups B

(a, b) must not exceed the dimensions specified for trials tyres refer to diagram. The overall width, measured at wheel spindle height must not exceed 150mm. Tread depth (A) must not exceed 13mm. All tread blocks in the same circumference must be of the same depth. The space between the tread blocks (B) must not exceed 10mm across the tyre or 13mm in a circumferential direction (C). The space between the shoulder blocks (D) must not exceed 22mm. The space across the tread (E) must not extend completely across the tyre measured at right angles to the tyre wall unless

main tread blocks must in principle be parallel with or at right angles to the

tyre axis. (The tyre must have the same appearance if reversed and conform in principle with these diagrams). The tread pattern of the tyre must not be modified.

4.4 MUDGUARDS AND WHEEL PROTECTION

Category 1, Group A and B motorcycles must be fitted with two mudguards giving protection to the driver. The rear mudguard must extend laterally beyond the tyre and cover at least 35 degrees of the upper front quadrant of the rear wheel, and must extend to 5 degrees or more behind a vertical line running through the rear wheel spindle and must extend to the full width of the tyre. The Clerk of the Course may permit the removal of the front mudguard if conditions make this desirable. If cast or welded wheels are used for all types of Track Racing a protection must be provided by enclosing the spokes with solid discs. The Sidecar wheel mudguard must extend to the full width of the tyre. Dirt Deflectors (DD) – The 'flap' must retain its original shape. Any 'flap' that is distorted, holed, worn through, cut or dismembered must be replaced prior to racing. The DD 'flap' must remain effective under all track surface and wind conditions. The DD 'flap' must be shaped and positioned in such

a way that the distance of the upper 'flap' edge to the complete tyre tread width. The opposite lower edge shall be 35mm maximum (+/- 5mm) from the track surface over an equal distance. All of the measurements are taken with the motorcycle in a vertical position, with the tyres normally inflated but without a rider. The mechanism must maintain constant function of the pivot arrangement and be able to return the DD 'flap' to its normal operating position with minimal delay. To measure the tension provided by the mechanism of the DD, a vertical balance shall be used to measure an equivalent minimum pre-load of 6kg for 1000cc Sidecars. The vertical balance must be attached to the outer edge of the DD holder in line with the centre of the tyre.

If 'Huggers' are fitted to protect the rear wheel of Solo machines competing at ACU domestic events, they must comply to FIM regulations and be mechanically fitted to the machine.

4.5 WHEEL RIMS

The modification by drilling to the wheel rims is prohibited other than for spokes, valve, security bolts or tyre retention screws. If the rim is modified for tyre security bolts, or tyre retention screws etc. then they must be fitted.

4.6 ALL CONTROL LEVERS

All ball ended levers (fitted to any machine) must be a minimum of 16mm min diameter. The end of levers when closed must not be situated wider than the furthest extremity of the handlebar.

4.7 FOOTRESTS AND HANDLEBARS

The footrest for the driver must be positioned to give easy access to any control pedal. The ends of the footrest must be rounded with a spherical radius of not less than 8mm viewing from front and end of footrest. The ends of the handlebars on all motorcycles shall be rounded or protected. Footrests must be mounted on an independent pivot.

When light alloy handlebars are used, the distance between the two extremities of the clamping area (or of the two clamps) must not be less than 120mm and handlebar clamps must be very carefully radiused and engineered so as to avoid fracture points in the bar.

Maximum handlebar width (Solo machines)

85cc/125cc	Min 650mm	Max
850mm	140cc/250cc/350cc/500cc	Min 700mm
Max 900mm		

4.8 FRONT ENGINE PLATES SOLO – MACHINES

Where appropriate, the void between the front engine plates of Solo machines below the dirt shield, if fitted, must be covered with a permanently fixed shield or plate.

4.9 OPEN TRANSMISSION GUARDS

The primary transmission must have a fully enclosed guard. The cutting of the guard is only permitted to expose the clutch pressure plate and allow adjustments to the clutch springs. An additional protection must be provided to prevent a broken primary chain from flying upwards. This can be provided by either a fully enclosed steel chain guard or, if a plastic chain guard is used, a steel bolt of 10mm minimum diameter, placed outside the bottom rear quadrant of the clutch sprocket. This bolt, if damaged, must always be completely replaced. On all machines chain guards must be fitted to cover the entry to the gear box and rear wheel sprockets.

4.10 IGNITION CUT-OUTS

An ignition cut-out operated by a lanyard which disables the machine in the event that the driver dismounts must be fitted to all machines. Cut-outs must function when the lanyard is pulled from any direction. The lanyard must be non-elastic and made of one constant material. Coiled telephone cable or similar materials are not permitted. The cut-out must operate on the low voltage circuit and be fail safe when operated. In addition, any part of the cut-out which remains live after actuation must be shrouded in order to prevent accidental contact re-establishing the current flow. The use of the handlebars or front forks as part of any circuit is not permitted. The length of the cut-out lanyard must be short as possible and attached to the competitor's/mechanic's wrist whenever the engine is running including push starting the machine and warming up the engine. Cut-outs will be checked prior to practice. In cases where there are time limitations or noise constraints, cut-outs will be tested as the machine enters the track for first practice. Machines must not be started before Technical Inspection
– cold engines only.

4.11 CARBURETTORS OR OTHER AIR INPUT CONTROL INSTRUMENTS

All Track Racing engines must be fitted with one carburettor with a maximum choke size of 26mm for 140cc and 34mm for 250cc, 350cc and 500cc engines + 0.1mm circular shape. Air Filters: Air filters can only have a dust prevention fluid added to them, any other additive is prohibited.

4.12 SUPERCHARGERS

The use of superchargers and turbo chargers on Solo machines is prohibited.

4.13 CHASSIS CONSTRUCTION

The use of titanium in the construction of the frame, the front forks, handlebars, swinging arm and swinging arm spindle, front and rear wheel spindles is strictly forbidden. The use of light alloys for wheel spindles is also forbidden. The use of titanium alloy nuts and bolts is allowed.

4.14 EXHAUST SYSTEMS AND CONTROL OF EXHAUST SOUND LEVELS

Solo – The exhaust system of a Solo machine must not extend beyond the outer circumference of the rear tyre. Between the silencer and the tyre a maximum gap of 60mm must not be surpassed. The exhaust fumes must be discharged from the system horizontally and parallel to the centre line of the machine. The exhaust pipe of a Solo track racing motorcycle must be fixed to the cylinder head and frame with a minimum of three clips (the point of fixture at the cylinder head is considered as one clip). The diameter of the exhaust pipe must not exceed 50mm diameter or an equivalent area and must remain constant up to the silencer. The outlet area of the silencer must remain constant over a length of 50mm and must not exceed 45mm or an equivalent area.

500cc Solo and Sidecar Machines – must use a 2010 FIM Homologated silencer. The only exception are machines using engines not designed for Track Racing where an alternative silencer must be used and will be subject to sound control using the new FIM 2 metre Max method of testing.

250cc and 350cc Solo Machines – must use either the 2010 or any FIM Homologated silencer.

The only exception are machines using engines not designed for Track Racing where an alternative silencer must be used and will be subject to sound control using the FIM 2 Metre Max Sound Levels. **Pre 75 and Upright Solo Machines** – must use either the 2010 or any FIM Homologated silencer. The only exceptions are machines using engines not designed for Track Racing where an alternative silencer must be used and will be subject to sound control using the FIM 2 Metre Max Sound Levels. **1000cc Sidecar Machines** – will be subject to sound control using a 'Ride By' method with a maximum sound level of 85dBA. The sound meter will be positioned in the middle of the centre green opposite the finish line, the sound meter will face the finish line or directly opposite on the back straight if the wind is blowing towards the sound meter.

If a machine is over the maximum sound level and the competitor disputes the sound meter reading, the machine will be tested to the '2 Metre Max Method'. If the competitor refuses to undertake the '2 Metre Max' sound test or if the machine cannot be tested to '2 Metre Max' sound method satisfactorily (e.g. the engine will not rev to near the maximum revs) the Ride By Sound reading will prevail without appeal.

200cc and Lower Machines (including 140cc) – will be subject to sound control using the current ACU sound control method.

For Sidecar Category B1(c) 500cc exhaust systems see specification 4.16(b).

All Machines – The outside shell of a silencer must form one integral unit in order to prevent any parts being dropped during a race. The end of the pipe must be cut at a right angle. The silencer must be fixed to the frame with at least one clip. In addition, for reasons of safety, a second flexible coupling must be fitted from the first third of the silencer to the frame (for example: a steel cable of at least 3mm diameter). The use of intermediate expansion boxes on two-stroke machines is permitted.

All Sidecars (except 1000cc Left Hand class) – Any silencer exposed across the front of a machine MUST be covered.

4.15 SPECIFICATION OF THREE WHEELERS CATEGORY 1 (1000CC SIDECARS)

All motorcycles in Group B1 (a, and b) shall comply with the following:

- a) The three wheels shall be each of at least 400mm (16") in diameter measured over the outside of the tyre.
- b) Where wheels are not wire spoked they must be enclosed with a disc.
- c) The wheel track, or lateral distance between tracks, shall be at least 800mm (32").
- d) Chains: The top and bottom runs of the drive chains and points of connection must be shielded.
- e) A passenger must be carried in addition to the rider.
- f) All Sidecars must be on the left hand side of the motorcycle except where special dispensation has been granted for races confined to Sidecars affixed to the right hand side of the motorcycle.
- g) All Sidecars must be rigidly fixed to the motorcycle. On level ground the maximum incline of the Sidecar wheel must not exceed 25 degrees. The maximum incline of a Class B1 (a) (1000cc) motorcycle must not exceed 5 degrees from the vertical. The Sidecar wheel must be completely covered on the outside by a disk extending to the wheel rim. No light alloy bolts shall be used in the attachment of the Sidecar or Sidecar wheel.
- h) The Sidecar wheel may be covered by a fairing. If such a fairing is fitted it must be constructed of fibreglass, plastic or similar material and must not provide a danger to any competitor. No part of any Sidecar fairing may extend beyond a vertical line drawn through the rear edge of the back tyre. If the Sidecar wheel is to be enclosed by a fairing it must be contained within a continuous 25mm horizontal supporting bar, fixed rigidly to the Sidecar platform at Sidecar floor height. On the right hand side of the machine any single projection within the diameter of the rear wheel and tyre must not exceed 100mm (4") measured horizontally from the outside of the rear wheel fork slot. Where a single projection as an extension to the rear spindle is used, this must have a minimum diameter of 25mm, be ball-ended and covered with a rubber ferrule.
- i) The maximum capacity of machines permitted in Sidecar races shall be: Class B1 (a and b) maximum 1006cc, unsupercharged, 650cc supercharged maximum.

- j) For all 1000cc Sidecar machines – Class B1 (a and b) – dirt deflectors must be used. Where a machine is fitted with a dirt deflector it will replace the mudflap.
- k) No part of the passenger hand-rail on a Sidecar may be less than 255mm from the outer edge of the Sidecar (this includes the wheel and wheel arch).
- l) The front of the Sidecar chassis must allow reasonable lift of the rear wheel. Where foot boards are fitted to the motorcycle, there must also be reasonable lift of the Sidecar wheel before the foot boards foul the ground.
- m) Protection for the passenger must be provided on three-wheelers from the rear wheel, the primary and final drive chains of the motorcycle and from the Sidecar wheel.
- n) The front and rear wheels, when measured from the centre lines of each wheel at ground level (in direction of forward travel and with correctly inflated tyres) may be displaced by a maximum of 75mm.
- o) Methanol, of a commercial make, is the only permitted fuel. The use of octane boosters is forbidden. On liquid cooled engines, an overflow pipe must direct any overflowing coolant away from the rider and passenger into a catch tank. The use of fuel additives is prohibited, with the exception of oil for two stroke engines. Fuel injection is permitted. Fuel tanks must be constructed of a material that will neither shatter nor splinter upon impact.

4.16 SpECIFICATION OF THREE WHEELER CATEGORY B1(C) 500CC

- a) **General Specification.** For all races, only single cylinder 4-stroke engines are allowed. The maximum capacity is 500cc, 4 valves maximum fitted with one carburettor, maximum diameter 38mm and one spark plug.
- b) **Exhaust System.** The exhaust must not extend beyond the outer circumference of the rear tyre and must not end further forward than the centre of the rear wheel. Between the silencer and the tyre there must be a maximum gap of 60mm. On a Sidecar machine the exhaust must discharge horizontally and towards the rear, at a maximum angle of 30 degrees to the axis of the machine, and at the end be of a constant diameter over a distance of 50mm. FIM homologated silencers must be used, in line with the current sound control regulations and a FIM approved heat shield must be fitted.
- c) **Brakes.** Brakes are not permitted on 500cc Sidecar motorcycles.
- d) **Footrests.** For Track Racing Sidecars the footrest on the opposite side to the Sidecar must be protected at the front by a crash bar connected to the frame so that injury or breakdown to other participants is prevented. The footrest must be fitted at a height of at least 150mm from the ground.
- e) **Mudguards and Wheel Protection.** For 500cc Sidecars, the mudguard of the rear wheel and the mudguard of the Sidecar must extend within 200mm from the ground. Protection from the Sidecar wheel and the rear wheel for the passenger must be provided down to the level of the Sidecar platform. The Sidecar wheel must either be completely covered by a disc extending to the wheel rim, or the Sidecar mudguard must extend downwards on the outside of the centre of the wheel spindle.
- f) **Tyres.** No specification for front and Sidecar tyres. For the rear tyre the overall width must not exceed 100mm and the only tyres allowed are those with Track Racing, Speedway or Trials tyre tread pattern.
- g) **Wheels and Rims.** Front wheel: Minimum rim diameter 18", minimum diameter of wheel spindle 15mm, solid steel shaft permitted only, minimum diameter of spokes 3.5mm M4 steel, spoke facing must cross twice. Rear wheel: Minimum rim diameter 18", maximum rim diameter 22", minimum diameter wheel spindle 17mm, solid steel shaft permitted only, minimum diameter of spokes 4mm M4 steel, spoke facing must cross twice. Sidecar wheel: Maximum rim diameter: 16". Maximum wheel inclination of 30°, measured from the vertical to the inside (controlled by angle measuring instrument and spirit level). Position: One-sided wheel spindle

diameter of 25mm minimum at the point of the highest moment of deflection; solid steel; or, diameter of 15mm if supported on both sides of the wheel. The Sidecar wheel spindle must not be welded in position. It must be screwed on, for example, by collar or clamp, with at least

three M8 screws. The minimum length of the clamp is 100mm. For construction using a clamp, protective devices against the loss of the component or failure of the clamp must be provided. Clamp construction in two places is forbidden. All wheel shafts must be secured by a nut with a secondary safety device e.g. split pin, R clip or circlip.

- h) **Sidecar Specification.** The minimum ground clearance at the front edge of the Sidecar platform is 150mm. The ground clearance of a laden Sidecar (with a rider and passenger) must be no less than 100mm at any point. The distance between the tracks left by the centre lines of the rear motorcycle wheel and the Sidecar wheel must be at least 800mm and not more than 1100mm. On the opposite side of a 500cc Sidecar, the exhaust pipe must not extend more than 330mm from the centre of the machine. On the Sidecar side, the exhaust pipe must not extend beyond the width of the Sidecar. The furthest extremity of the exhaust pipe must not exceed the vertical line drawn at a tangent to the rear edge of the rear motorcycle tyre or the rear edge of the Sidecar platform whichever is shorter. The outside of the 500cc Sidecar wheel shall be provided with horizontal tubular protection (minimum tube diameter 25mm) fixed at the same height as the Sidecar wheel spindle. No component shall protrude beyond this protection. The inclination angle of the motorcycle must not exceed 15°.

4.17 ADDITIONAL (OLD AND NEW) SIDECAR CLASSES

1. Pre 1980 Class

- a) For machines fitted with British made twin cylinder engines, initially designed for mass produced road bikes (up to 650cc supercharged and 1000cc naturally aspirated). For 650cc machines actual maximum capacity will be based on manufacturer's standard rebore sizes
- b) Chassis and running gear to be based upon the type commonly in use pre 1980.
- c) British twin shock, no 2 speed gear boxes.
- d) Dirt deflectors are not mandatory in this class. If a dirt deflector is not used, a flexible mud flap must be securely fixed, minimum thickness 10mm and 150% of the overall tyre width. The bottom edge of the mud flap must be within 35mm of the ground when laden.
- e) All current safety and environment requirements must be respected.

2. 500cc Twin Cylinder Class

- a) For machines fitted with parallel twin cylinder engines initially designed for mass produced road bikes (naturally aspirated)
- b) Standard 500cc air cooled parallel twin, mass produced, running on standard petrol. Carburettors and electrics must be standard manufacture for the engine used in the motorcycle.
- c) Chassis to be based on current requirements.
- d) Dirt deflectors are not mandatory in this class. If a dirt deflector is not used, a flexible mud flap must be securely fixed, minimum thickness 10mm and 150% of the overall tyre width. The bottom edge of the mud flap must be within 35mm of the ground when laden.
- e) All current safety and environment requirements must be respected.

4.18 TRACTION CONTROL

The forward motion of a motorcycle must be controlled by the rider only, and the regulation of speed shall be through the use of throttle, clutch, gears and brakes when fitted.

Throttle opening must be controlled by cable only, no 'fly bye wire' type throttle actuation is permitted. Rider aids whether a part or full system fitted on a machine/engine CANNOT be used and are not permitted.

4.19 FUEL

Fuel may be methanol or unleaded petrol. Please refer to the ACU and FIM fuel regulations for physical properties, fuel test costs, and penalties for non-compliance. Power boosters and octane boosters are forbidden. Fuel may only be retailed from a point of a minimum of 7 metres from any other vehicle. The area must be roped off and the retailers must display 'No Smoking/Vaping' and 'No Naked Lights' signs, in addition to any other requirements requested by the local authorities. Fuel must only be dispensed in clearly labelled containers. No smoking also applies to all Electronic Cigarettes. Mobile phones should not be used when refuelling machines.

4.20 OIL CATCH TANKS

Must be securely fitted to all four stroke machines using a total loss lubrication system. Oil catch tanks must be connected at all times and be emptied after each race. Oil catch tanks must be securely fitted to all machines with engines that require an oil breather system.

4.21 NUMBER PLATES

Whenever number plates are required to be used at an event they will be three in number and must comply with the following requirements. Both classic and Pre-75 machines may be granted a dispensation to this rule. Number plates must be of durable construction with the minimum dimensions height 235mm × width 285mm. The front plate must be rectangular with 50mm radius to the corners. The plates must be flat or slightly curved (not more than 50mm from the true plane) and must not be otherwise bent or obscured in any way. One plate must be carried forward and not more than 30 degrees from the vertical and the others must be facing outwards and vertical (one on each side of the machine). Side facing plates can be oval. They must be so fixed that they are clearly visible and not obscured by any part of the machine or by the driver or passenger when in the riding position. **It is the responsibility of the competitor to ensure that racing numbers are clearly visible for lap scorers.** The minimum dimensions of the figures must be: height 140mm, width 80mm, width of stroke 25mm and the space between any two figures 15mm. The number plate size relates to a two digit number. Should a three digit number be used then an increase in the size of the plate will be required. Numbers cannot be 'joined up' - single figures only with no outline around the outside of each figure. The figures must be legible and both figures and background must be in a 'matt'

(non-shiny) colour. The colours shall be as follows:

Front and Side Number Plates – Background Colour and Number colour

Capacity – Solo's	Number plate Background Colour	Number Colour
250cc	Green	White
Over 251cc to 350cc	Blue	White
351cc to 500cc	Yellow	Black

Capacity – Sidecars	Number plate Background Colour	Number Colour
B1c	Yellow	Black
B1a, B1b	Black	White
GT140	Black	White

Where yellow, green or blue are required the colours shall comply with BS4800: 1972 as follows: Yellow 10E526 Green 14E53 Blue 18E53.

Any other number plate or any marking on the motorcycle that might be confused with a number plate must be removed before the rider is allowed to start.

Streamlining – Streamlining is NOT permitted on any Solo machine. Streamlining is defined as any addition to the handlebars or to the frame of the machine, the effect of which is to shield the rider's arms, legs or body from the air stream.

4.22 qUADS

Grass Track Quads are limited to a maximum engine capacity; a two stroke engined quad should not exceed 550cc. Whether two stroke or four stroke the engine must have no more than two cylinders up to 550cc. The maximum engine capacity for a four stroke engined quad should not exceed 700cc and be single cylinder. Quads eligible for the 250cc class are allowed a 10% oversize but are not allowed to exceed 275cc. Motocross riding gear must be worn at all times. Track safety roping is to be set out as in accordance with the Grass Track Sidecar safety roping regulations. Lanyard cutouts must be used and attached to the rider's wrist as per Track Racing Regulations.

Youth – Quads are not permitted in youth events without agreement from the Track Racing Committee.

For Quads a third number plate must be fitted running parallel with the machine at the rear, readable when facing the side view of the machine. The mounting bracket must not exceed 25mm in a vertical plane from the mounting point.

All other specifications as in Quad/ATV Motocross Standing Regulations and National Sporting Code Appendix D.

4.23 CLASSIC pRE-75 SOLO GRASTRACK MACHINES

These guidelines are for Solo machines in accordance with equipment which was in common use up to 1975.

- a) **Standing Regulations.** All machines must comply with the Standing Regulations for Track Racing as given in the current edition of the ACU Handbook with the exception of the following:
- b) **Frame.** The frame should ensure that the engine is mounted in a near upright or vertical position. The rear suspension, if fitted, should incorporate a swinging arm with suspension units mounted on each leg of the swinging arm and onto the rear sub frame. Monoshock rear suspension is not permitted. Only telescopic style front forks are permitted. Leading link style forks are not permitted.
- c) **Four Stroke Engines.** The engine will have one inlet and one exhaust valve per cylinder. The inlet port of the cylinder head must be angled towards the right hand or left hand side of the machine. Central carburettor cylinder head design are not permitted. On a pre unit construction type engine the lubrication system will be total loss type with an oil catch tank fitted as per Grass Track Technical Rule 4.20. On a unit construction type engine a recirculatory oil system will be permitted.
- d) **Two Stroke Engines.** The engine will be of air cooled design and be of a type commercially available up to 1975. Water cooled engines not permitted.
- e) **Carburettor and Ignition System.** No restriction.
- f) **Transmission System (gearbox and clutch).** No restriction.
- g) **Mudguard.** Number plates and dirt shields etc. In keeping with the styles and types available of the period (plain designs and colours are preferred)
- h) **Wheel Sizes.** No restriction.
- i) **Brakes.** As per Grass Track Standing Regulations rule 4.2.

The object of the above guidelines are to ensure that all Club Officials and competitors are aware of the construction requirements so that the possibility of a dispute at an event is reduced. It is recognised that certain parts will be of modern manufacture, this will be accepted as long as the above guidelines are adhered to.

4.24 pOST-CLASSIC pRE-1990 UpRIGHT SOLO GRASSTRACK MACHINES

These guidelines are for Solo machines in accordance with equipment that was in common use between 1976 and 1990.

- a) **Standing Regulations.** All machines must comply with the Standing Regulations for Track

- Racing as given in the current edition of the ACU Handbook with the exception of the following:
- b) **Frame.** The frame should ensure that the engine is mounted in a near upright or vertical position. The rear suspension, if fitted, should incorporate a swinging arm with suspension units mounted on each leg of the swinging arm and onto the rear sub frame. (MONOSHOCK REAR SUSPENSION IS NOT PERMITTED) Both telescopic style and leading link type front forks are permitted.
 - c) **Four Stroke Engines.** The engine will be of a type commercially available between 1976 and 1990. The engine will have two inlet and two exhaust valves per cylinder. The inlet port of the cylinder head may be angled towards the right hand or left hand side of the machine or mounted centrally from the cylinder head. The engine the lubrication system may be either a recirculatory system or a total loss system. If the engine is a total loss system then an oil catch tank must be fitted as per Grass Track Technical Rule 4.20.
 - d) **Four Stroke Engine Carburettor.** Must have a maximum choke/venturi diameter of 34mm.
 - e) **Two Stroke Engine.** The engine will be of a type commercially available between 1976 and 1985. Both air cooled and water cooled engines are allowed.
 - f) **Two Stroke Engine Carburettor.** Must have a maximum choke/venture diameter of 38mm.
 - g) **Ignition system.** No restriction.
 - h) **Transmission system (gearbox and clutch).** No restriction.
 - i) **Mudguard.** Mudguards, number plates and dirt shields etc. will be in keeping with the styles and types available of the period.
 - j) **Wheel sizes.** No restriction.
 - k) **Brakes.** As per Track Racing Technical rule 4.2 (ACU Handbook).
 - l) **Silencers.** All machines must adhere to the current ACU Sound Regulations, as set out at 4.14 above.

The object of the above guidelines are to ensure that all Club Officials and competitors are aware of the construction requirements so that the possibility of a dispute at an event is reduced. It is recognised that certain parts will be of modern manufacture; this will be accepted as long as the above guidelines are adhered to.

4.25 FORMULA GRASS TRACK

- a) All machines must comply with the Standing Regulations for Track Racing as stipulated in the current edition of the ACU Handbook except for the following:
- b) 1. Honda Engine – a standard street legal 100cc – 125cc single cylinder, two valve, 4 stroke air cooled. Standard specification as per HAYNES MANUAL i.e. Bore 56mm Stroke 49.5mm comp ratio 9.5:1 etc
- c) No engines designed for 'Off Road' use e.g. XR range
- d) No interchanging of parts that would alter the standard specification of the engine.
- e) Standard up to 125cc single cylinder, two valve, 4 stroke, air cooled horizontal engines (e.g. Pit bike style engine).
- f) Gear Box – standard ratios only. No close ratio gears. No pinions to be left out of the gear box, the full cluster must be fitted.
- g) Carburettor – any make of carburettor. Carburettor must be upright.
- h) Ignition – any type including electronic. Rotor and stator plate may be removed.
- i) Fuel – petrol, normal pump grade. METHANOL IS NOT ALLOWED
- j) Tyres
 - Senior Class – Rear tyre restricted to Grass Track/Speedway/Trials tread patterns only.
 - Maximum width 3.75 ins (95mm) No tyre cutting in any form will be allowed.
 - Youth Classes – no restriction as per ACU technical regulation 4.3

k) Classes and number plate colours

Class	Background Colour	Number Colour
Cadets/Auto Cadets 6–8 years	White	Black
Cubs 9–12 years	Red	White
Juniors 12–16 years	Green	White
Seniors 16+	Black	White

4.26 GT 140

- a) Standing regulations must comply for Track Racing machines with current technical regulations for the GT 140 class.
- b) Frame can be a Grass Track twin shock or mono-shock incorporating a swinging arm with suspension, a Speedway rear subframe is not permitted.
- c) Forks can be any type. Leading link or telescopic.
- d) Wheels: Front – 23 inch Rear – 22 inch as per current regulations
- e) Engine: Maximum 140cc with 2 valves.
- f) Fuel: Petrol only, methanol is not permitted.
- g) Carburettors inlet must not exceed a maximum diameter of 26mm. Carburettor must be upright.
- h) Number plates (refer to 4.21) must be displayed on the front and either side at the rear of the machine.
- i) Brakes are not permitted as per Grass Track regulations 4.2.
- j) The rear silencer must be fitted with a retaining wire to ensure it does not become detached from the motorcycle during racing.
- k) Mudguards: Regular Grass Track guards or huggers kits are permitted.
- l) Ignition cut out system must be fitted to disable the engine via a lanyard attached to the rider.
- m) Chain: The rear chain must be covered on any area where the chain meets the front and rear sprocket.

4.27 INTERNATIONAL 125CC FOUR STROKE SPECIFICATION

For International 125cc and 250cc four stroke specifications, refer to current FIM/FIM EUROPE technical specifications. These classes will run without brakes. Other than events run to FIM/FIM EUROPE rules brakes must be fitted. Braked and non braked machines must not compete in the same race. The specification of machines in these classes will be in accordance with FIM Rules which are available from ACU Head Office.

SECTION 5 SAND/BEACH RACING

As per Grass Track Standing Regulations with the exception of:

- a) Maximum twelve where on-track start
- b) MX classes – Specification of the motorcycle: Refer to Section 5 of the MX Standing Regulations for basic specification of motorcycles, which MUST ALSO INCLUDE:
Lanyard cut outs
Chain guards as per Grass Track standing regulations.
- c) MX classes to also include Enduro machines. ALL other Grass Track Standing Regulations apply to MX classes

THREE WHEELER CATEGORY 1. GROUP B1 (A, B)

- a) Maximum Capacity of Sidecars 1040cc (to accommodate FIM Sidecar Speedway regulation machines).
- b) Supercharged up to 650cc. 651cc to 1040cc – not supercharged.

SECTION 6 FLAT

TRACK

- 6.1 **Direction of racing.** Flat Track Racing will take place on an oval circuit or TT circuit (i.e. TT circuit with mainly left hand bends but can have up to two right hand bends and jump) and will run in an anti-clockwise direction.
- 6.2 **No of riders.** Track less than 400 metre in length – A maximum of twelve riders on the track in any race or practice session.
1/2 mile, Mile or TT Track – a maximum of sixteen riders on the track in any race or practice session.
- 6.3 **Practice.** The practice session at the beginning of the meeting is compulsory for all riders.
- 6.4 **Race Distances.** The duration of races will be as follows: six to eight laps for heat races, eight to ten laps for last chance/Semi Finals, twelve to sixteen laps for the Grand Final.
- 6.5 **Time Penalty.** Any rider not at the start line within two minutes of being called will be excluded from the race.
- 6.6 **Starting Infringement.** If a rider touches the tapes or jumps the start, the referee will place them twenty five metres back from the start line.
- 6.7 **Flags and Signals.** Riders must obey all signals given to them on the track. Chequered Flag – The finish of a race or practice sessions.
Yellow Flag – Danger in this section of the track, overtaking is prohibited.
Red Flag or Red Light – The practice or race is being interrupted. Riders must slow down, return to the pits and await further instructions from the Clerk of the Course.

SECTION 7 FLAT TRACK TECHNICAL REGULATIONS

The basis for the specification will be Motocross, Enduro, Supermoto and Dirt Track machines.

- 7.1 Engine Displacement. 2 stroke 125cc to 500cc, 4 stroke 250cc – unlimited.
- 7.2 Besides the compulsory adjustments, alterations may be applied to the frame and the appearance of the machine.
- 7.3 The front forks must not protrude more than 5cm above the upper attachment of the suspension.
- 7.4 The rear wheel must be able to stop instantly, so an efficient braking system on the rear wheel is mandatory.
- 7.5 Front wheel brakes are prohibited and all the components relating to a front brake must be removed.
- 7.6 Only the following tyres are permitted: Maxxis DTR, Dunlop DT, GoldenTyre FT, Barum DT.
- 7.7 The rear sprocket should be guarded with a shark fin type protector.
- 7.8 The gearbox sprocket must be suitably protected.
- 7.9 Only fuel that can be purchased from a roadside petrol station is permitted.
- 7.10 A Lanyard type cut-out must be fitted to all machines.
- 7.11 Foot pegs should be in their original position on the frame or no lower than the frame itself.
- 7.12 The noise level of any machine must not exceed 89dBA at 2 metres.

SECTION 8 1000CC SIDECAR SPEEDWAY REGULATIONS

8.1 DEFINITION

To be deemed as eligible for competition in 1000cc Sidecar events on Speedway circuits, the motorcycle shall be in conformity with the following requirements: The motorcycle must have three rolling wheels. The Sidecar wheel must be on the left hand side of the motorcycle. The drive must be transmitted to the track surface through the rear wheel of the motorcycle.

The motorcycle must at all time carry a rider and a passenger. Brakes are not permitted.

Rear wheel suspension is optional.

The passenger must sit astride the motorcycle

The motorcycle shall always race in a clockwise direction.

8.2 DIMENSIONS

The overall length from the leading edge of the front tyre to outside of the rear mudguard must not exceed 2600mm. The overall width must not exceed 1500mm.

The wheelbase, measured from the centre of the front spindle to the centre of the rear spindle, must measure between 1280mm and 1800mm. The wheel track, measured between the centre lines of the track left by the rear and Sidecar wheels, shall be a minimum of 800mm and a maximum of 1100mm. The front and rear wheel must be aligned as such that the centre line of the tracks made by the motorcycle is proceeding directly forward, must be no further apart than 75mm.

The width of the running board on the right of the motorcycle must not exceed 400mm. The angle of inclination of the main body of the motorcycle must not exceed 10° from the vertical. The minimum ground clearance at any point of the Sidecar shall be 75mm unloaded.

8.3 ENGINE

The engine capacity shall not exceed 1000cc. Engines may be bored up to 1006cc (no further tolerance).

8.4 MINIMUM WEIGHT:

- I 180kg with empty fuel tank. Coolant tank must be full.

8.5 FUEL, OIL AND COOLANTS

Methanol, of a commercial make, is the only permitted fuel. The use of octane boosters is forbidden. On liquid engines, an overflow pipe must direct any overflow coolant away from the rider and passenger into a catch tank.

The use of fuel additives is prohibited, with the exception of oil for two stroke engines. Fuel injection is permitted.

Fuel tanks must be constructed of a material that will neither shatter nor splinter upon impact.

8.6 EXHAUST SYSTEMS

Exhaust pipes and silencers may be of a "baffle" or "absorption" type and must fulfil the requirements concerning noise control.

An exhaust extraction (megaphone types) effect must not be caused by the positioning of any tapered, conical or other shaped parts.

The exhaust pipe must be fixed to the cylinder head and frame with a minimum of three clips (the point of fixture at the cylinder head is considered as one clip). The silencer must be fixed to the frame with at least one clip.

Additionally, a second flexible coupling must be fitted from the first third of the silencer to the frame (steel cable of at least 3mm diameter for reasons of safety) or a solid steel spring.

Exhaust fumes must be discharged towards the rear but not in a manner as to raise dust, foul the tyres, or inconvenience a passenger, or any other riders.

The entire exhaust system must be contained within the fairing, to ensure that the exhaust system cannot come in contact with any rider, passenger, or other motorcycle.

8.7 WHEELS, RIMS AND TYRES

The front tyre and Sidecar tyre must be of a 'trial' type pattern. Maximum sizes for rear wheel rim: 5.00" x 19".

The Sidecar wheel diameter must be between 16 and 19 inches and must camber inwards. Cast or welded wheels must be covered with a disc or other suitable shield.

On level ground the maximum incline of the Sidecar wheel must not exceed 25 degrees, with the Sidecar being fixed rigidly to the motorcycle

The Sidecar wheel can be mounted with plates on both sides. If this situation exists the spindle

diameter must be min. 12mm. If the Sidecar wheel is mounted with a bracket on one side, the spindle diameter must be min. 20mm. The rear and front wheel must be fitted with knockout spindles. The use of light alloys and titanium in the manufacturing of wheel spindles is forbidden.

8.8 SIDECAR pLATFORMS

If the Sidecar platform is not an integral part of the frame, the platform must be rigidly fixed to the motorcycle in at least four places.

Any space between the Sidecar platform and the rear wheel of the motorcycle must be covered to ensure that the passenger's hands and feet cannot be trapped in the driving chain or the rear wheel. The Sidecar wheel must be contained within a continuous 25mm horizontal crash bar, fixed rigidly to the Sidecar platform at Sidecar floor height.

Any open area in the Sidecar platform inside the continuous crash bar, and on the running board on the near-side, must be filled with a suitable material to prevent either the rider or passenger from trapping their feet.

8.9 DIRT DEFLECTORS, MUDGUARDS, FAIRINGS

A dirt deflector is compulsory and must be of a type homologated by the FIM. The dirt deflector flap holder must be constructed of a non-metallic material.

The dirt deflector must be fitted adjacent to the rear wheel and is required to deflect "wheel-spray" or track surface material downwards in order to minimise the inconvenience caused to other riders, spectators, and the soiling of track-side notices and equipment.

The return mechanism must have a minimum pre-load of 6 kilos (to be monitored during the season and reviewed if required). The lower flap edge of the deflector must be 35mm (± 5 mm) from the track surface.

The dirt deflector arm must be modified to ensure that the blade and flap are correctly positioned behind the rear tyre.

A rear mudguard must be fitted, and extend from the rear seat to a maximum of 150mm from the ground (when the Sidecar is laden).

The outside of the Sidecar wheel and tyre must be covered by a non-rotating shield or fairing. This fairing must be securely fixed to the Sidecar and outside of the crash bar.

All fairings and nose cones must be constructed of fibreglass, plastic, or similar material.

They must be smooth, free of any sharp or protruding edges, and must not provide a danger to any other competitor. The minimum clearance between streamlining and the ends of the handlebars or their attachments is 30mm with the front wheel in any position. No aero foils or similar devices are permitted.

No part of any nose cone or fairing may extend beyond a vertical line drawn through the leading edge of the front tyre. No part of the Sidecar fairing may extend beyond a vertical line drawn at a tangent to the rear edge of the back tyre.

8.10 FRAME

The use of titanium and composite materials in the construction of a frame is completely forbidden. An efficient steering damper may be installed.

8.11 THROTTLE CONTROLS AND IGNITION CUT OUTS

Throttle controls must be self closing when not held by the hand.

The throttle must be controlled by cable only; no 'fly by wire' type throttle actuation is permitted. Rider aids, whether part or full system fitted on a motorcycle/engine CANNOT be used and are not permitted.

An ignition cut-out must be fitted on the handlebar, as close as practical to the throttle.

The switch must cut off the circuit of the electrical supply by the simple action of pulling a lanyard or a non-elastic cord (with a maximum length on 30cm), attached to the rider's right WRIST.

Note: Interrupting the electric supply by grounding the circuit is not a sufficient measure. The ignition cut-out lanyard must be attached to the operator's wrist when the engine is running. Ignition cut outs will be checked prior to practice to ensure they function correctly

8.12 MEETING FORMAT AND REGULATIONS

Details of the meeting formats and associated meeting regulations will be confirmed in the form of Supplementary Regulations that will be issued by the ACU TRC prior to the start of each season's series.

SECTION 9 YOUTH COMPETITOR REGULATIONS

The following regulations apply to youth competitors only.

9.1 ORGANISING PERMITS

An application for a permit to organise a competition shall be made on the appropriate form and sent to the appropriate Permit Issuing Officer as per the National Sporting Code. Permits for events where revenue is to be obtained from the general public will only be issued if the proceeds are donated to charity, a Steward must also attend any such meeting. If revenue is to be obtained from the general public, it must be clearly stated when applying for a permit. Additional insurance must also be taken out and only events of National status and above will normally be granted permission.

9.2 JOINT YOUTH/ADULT EVENTS

Youth classes may be included in adult events of below National status. The practice and racing for Youth classes must be run separately from the Adult classes and the age groups also separated. Adult clubs promoting joint events shall organise these under a joint permit, issued by the local Centre.

9.3 ADVERTISING

Commercial advertising in connection with Youth competitors in the press or in any publication is not permitted. Approval must be obtained from the ACU Headquarters, before any club/rider appears on TV or any other media.

9.4 RESPONSIBILITY FOR YOUTH ENTRANTS

The parent or guardian must accompany a Youth entrant to a meeting and stay for the duration that the rider is present. A competitor deemed unfit by First Aid personnel will be withdrawn from the meeting.

9.5 AGE GROUPS, ENGINE CAPACITY AND NUMBER PLATES

When a competitor reaches the maximum age for his or her group, they may continue in that group until the end of the calendar year, or upgrade on his or her birthday.

No competitor may compete before his/her 6th birthday. Competitors may compete until the end of the year in which their 17th birthday falls. A competitor may be upgraded to compete in Adult competitions on or after his/her 15th birthday, up to a maximum capacity of 250cc and may only

revert to Intermediate Class Youth competition. There are no restrictions to the type or level of youth event that a competitor may enter.

All competitors must be capable of sitting on their machines at the start line (unaided) with the machine in an upright in-line position with one foot firmly on the ground and the other on the footrest. Production Motocross machines will not be allowed in any other Grass Track class apart from the Cadets which must not exceed the stated capacity.

At joint Adult/Youth events, a rider must specify which class he/she will enter, and cannot ride Youth

and Adult at the same event. The maximum engine capacity sizes as stated in the table below applies to Youth Grass Track
The Youth Auto/Cadet Class: The Auto machines and the geared machines in this class can run separately or be amalgamated depending upon the number of entries received by an organiser. For the British Championship these will be run as separate classes.
For Quads refer to Motocross 2.2 on page 109.
For FIM Gold Trophy meetings and FIM EUROPE European Cups the minimum for each meeting starts on the competitor's minimum age birthday. The maximum age finishes at the end of the year in which the competitor reaches the maximum age.
Youth competitors are limited to 250cc engine size.

Class	Capacity – Engine Type	Age on 1st January	Number Plate Background Colour	Number Colour
Auto/Cadet	50cc Fixed Auto. 65cc–2 stroke 110cc–4 stroke	6–8 years	White Black	Black (Auto) White (Cadet)
Junior	up to 100cc–2 stroke 150cc–4 stroke	9–12 years	Red	White
Intermediate	up to 150cc–2 stroke 250cc–4 stroke	13–17 years	Green	White
MX Classes				
Junior 65cc MX	65cc–2 stroke 110cc–4 stroke	7–10 years	Black	White
Inter 85cc MX	85cc–2 stroke 150cc–4 stroke Wheel size 14" rear 17" front	9–12 years	Red	White
Senior 85cc MX	85cc–2 stroke 150cc–4 stroke Wheel size 16" rear 19" front	11–15 years	Green White	
International and European Classes				
FIME 125cc European Cup	125cc–4 stroke	10–16 years	Green	White
FIM 125cc Gold Trophy	125cc–4 stroke	12–16 years	Green	White
FIM 250cc Gold Trophy	250cc–4 stroke	14–17 years	Blue	White

Where yellow, green or blue are required the colours shall comply with BS4800: 1972 as follows: Yellow 10E526 Green 14E53 Blue 18E53.
Any other number plate or any marking on the motorcycle that might be confused with a number plate must be removed before the rider is allowed to start.

9.6 UpGRADING

On reaching the minimum age for the next group, the competitor may upgrade. Please note that any competitor who chooses to upgrade cannot then move back to the lower age group once they have competed at a higher level.

A competitor may be upgraded into the next higher group before reaching the age normally required subject to the following:

- a) The written agreement of the parent or guardian plus An endorsement by a current Youth Organiser plus The written approval of the Track Racing Committee
- b) For upgrading from Intermediate class to Dual Youth/Adult 250cc competition: This is only available to competitors from their 15th birthday until the end of the year in which their 16th birthday falls.

The written agreement of the parent or guardian plus An endorsement by a current Youth Organiser plus An endorsement by a National Grass Track Coach plus The written approval of the Track Racing Committee.

In limited circumstances, the Track Racing Committee may give approval to a competitor remaining in a lower class for an additional year following written application. Where approval is given, the competitor will not qualify for any National Championship points for that year.

9.7 AWARDS

Cash awards are not permitted in Youth events.

9.8 HOLDER OF A SpEEDWAY CONTRACT

Riders in possession of a Premiership League contract to a BSPA promoter will not be permitted to compete in Youth Grass Track events.

9.9 CONDUCT

Competitors, parents, guardians or associates failing to obey instructions given by Officials of a meeting or deemed to have unjustifiably or maliciously jeopardised the efficient running of the meeting, will be dealt with in accordance with the National Sporting Code.

9.10 MINORITY CLASSES

If a group has an entry of four or less, the Clerk of the Course, with agreement of the Secretary of the Meeting and parents, will decide if those riders will ride with the group above or below the group the competitors normally ride in. This should normally be the minority group either side, but only at below National status level.

9.11 STARTER'S ORDERS

Only those competitors in the starting area or on a grid will be deemed to be under Starter's Orders. No other competitor is subsequently permitted to start in a race. No parents or mechanics will be allowed on the start area once competitors have come under Starter's Orders. The only exception being the Auto Cadet and Cadet classes. A parent or mechanic of a rider in this group will be permitted on the start provided they stand at least six feet/1.8 metres from the rear of the machines at the starting gate.

9.12 CLOTHING

As per Grass Track Standing Regulation 3.2.

SECTION 10 GRASS TRACK EVENTS HELD ON SPEEDWAY CIRCUITS

To be implemented where ACU/ACU Events/ACU Clubs hold events on Speedway tracks. The ACU Grass Track Regulations shall apply to all Speedway events, where appropriate and the following Supplementary Regulations will become applicable when events of this nature are held.

- 10.1 Permits may only be issued in respect of Speedway tracks that are licensed by the Speedway Control Bureau and maintained to the minimum standard for Speedway racing.
- 10.2 For an ACU club event, the Centre within which the circuit is based will normally issue permits for these events.
- 10.3 A Steward and/or Referee will be appointed by the Permit Issuing authority who will conduct a track inspection prior to the event.
- 10.4 The maximum number of competitors in each race shall be four.
- 10.5 Machines and capacities shall be as in current ACU Grass Track Standing Regulations.
- 10.6 Youth riders must only compete against others in their age groups as in Grass Track Standing Regulations.

- 10.7 Marshals must be appointed to the inside of the track as per Grass Track safety requirements. If a Clerk of the Course/Steward is in control on the track then red warning lights may only be used as a supplement to the Marshals' warning flags. However if a judicial Clerk of the Course/ or Referee is using a control panel then they will operate the red lights when required with Flag Marshals responding immediately in support.
No marshals shall be on the centre green for Sidecar Speedway events.
- 10.8 Two WARNING NOTICES (Type A) must be prominently displayed on either side of the track entrance.
- 10.9 PROHIBITED NOTICES must be displayed in areas to inform spectators of safe areas.
- 10.10 Strictly only appointed meeting Officials shall be allowed on the track or in the centre of the arena during practice or racing.
- 10.11 Strictly only competitors, mechanics and meeting officials shall be allowed in the Pit area during practice or racing. No riding will be allowed in the pits.
- 10.12 Any competitor deemed to be the primary cause of a race being stopped will be excluded from the race.
- 10.13 When a competitor's motorcycle or any part of their body or equipment touches or breaks the starting tapes or prevents the raising of the start gate, then they will be excluded by the Clerk of Course/Referee.
- 10.14 Ambulance and First Aid cover must be in line with ACU Grass Track Standing Regulations.
- 10.15 Track marking and starting gates will be made with white chalk or similar material in contrast to the colour of the track surface and maintained in suitable condition throughout the meeting.

SECTION 11 TRACK RACING OFFICIALS

QUALIFICATIONS AND CONDITIONS

Track Racing Officials are divided into two categories: those who are Licensed and those who are Registered.

No fees are payable in respect of any licence or registration for the appropriate form of identification issued.

LICENCES: Senior Track Racing Officials are required to hold an ACU licence of the appropriate grade for the performance of their duties.

REGISTRATION: A register is maintained by the ACU of all licensed officials.

TRACK RACING OFFICIALS WHO REQUIRE A LICENCE

See note below regarding whether a licence and attendance at an ACU seminar is required

Official	Licence Required	Attendance at Seminar/ Training Session
Clerk of the Course/ Referee/Assistant Clerk of the Course	YES (once in any given three year period)	YES, every third year minimum
Chief Steward	YES (once in any given three year period)	YES, every third year minimum
Chief Technical Officer	YES (once in any given three year period)	YES, every third year minimum
Sound Inspector	YES	YES, required for first issue only
Measurer	YES	YES, required for first issue only

Clubs and Centres shall only nominate candidates whose aptitude and integrity for the position they can fully justify. Official ACU approval and the issue of a licence is only after the candidates have proved to be competent according to the special requirements for each discipline. The respective Committees and Panels organise seminars that are compulsory for certain officials. A licence is valid for 3 years unless as otherwise specified.

- Note 1 Clerk of the Course Grades//Referee Grades/Levels – Track Racing Restricted/Centre** – must undergo training at a seminar organised by a National Clerk of the Course.
National – must attend a seminar organised and presented by the ACU Track Racing Committee.
International – must attend a seminar organised and delivered by the FIM.
- Note 2 Chief Steward Grades/Levels Restricted/Centre** – will be appointed by the Centre as the Permit Issuing Authority.
International/National – will be appointed by the Track Racing Committee as the Permit Issuing Authority.
- Note 3 Chief Technical Official** – will be licensed by the Technical Panel. The Chief Technical Official will be responsible for the Technical control at an event. The Technical Panel may restrict the disciplines of licence holders.
- Note 4 Measurer** – the Measurer is required for ACU National Championships and National status events. The licence is issued by the Technical Panel and may be restricted by discipline.

Licence Fees: All ACU Officials licences will be issued, free of charge by the ACU.

TRACK RACING OFFICIALS WHO DO NOT REQUIRE A LICENCE

See note below regarding requirement for training

Incident Officer: may attend Clerk of the Course seminars held at ACU HQ to assist in his/her understanding of the safety requirements needed for organising and staging a successful event.

Secretary of the Meeting: will receive training at events via mentoring from personnel within the club or via support from another club's Secretary of the Meeting.

NB: an ACU Secretary of the Meeting Guidance booklet is available for reference purposes – please contact the ACU Track Racing Secretary for further information.

Technical Official: will receive training via the Chief Technical Officer at race meetings. May also attend Regional training seminars.

Club Stewards: may attend Regional or ACU HQ seminars for information purposes.

Chief Marshal: will receive training and mentoring by the Clerk of the Course.

NB: an ACU Marshals Guidance booklet is available for reference purposes – please contact the ACU Track Racing Secretary for further information.

Marshal: will receive training and mentoring by the Clerk/Assistant Clerk of the Course or Chief Marshal.

NB: An ACU Marshals Guidance booklet is available for reference purpose together with additional relevant documentation to assist in the training and recording of the training of Marshals. The documentation is available by contacting the ACU Track Racing Secretary. A Marshal's registration card will be issued by the ACU after training has been given by the Clerk of the Course.

Medical Officer: must be a qualified Medical Practitioner or Paramedic – training for this Official is not supplied by the ACU. Qualification is only possible via the appropriate professional body.

Rider Liaison Officer: refer to note 4 below

All other Technical Officials, Race Day Officials (e.g. Secretary of the Meeting, Incident Officer, Club Stewards) and Marshals may be registered, free of any charge. All such Officials may or may not be required to attend a seminar; however the appointing organiser must at all times be in a position to demonstrate competency and training in respect of the individuals concerned. Registration will be renewed annually. Registered Officials and Marshals will receive an appropriate form of identification from the ACU.

Note 1 Incident Officer: will collate all information and documentation, and prepare reports relating to serious accidents and to all incidents involving Officials or spectators. A Deputy Clerk of the Course may undertake these duties. An Incident Officer may be nominated to attend a Clerk of the Course seminar to assist with these duties.

- Note 2** **Secretary of the Meeting:** will be responsible for all administration connected with the organisation of a race meeting.
- Note 3** **Club Stewards:** will together with the Chief Steward, form the Judicial authority for the running and overseeing of the race meeting.
- Note 4** **Rider Liaison Officer:** may be appointed to assist the Clerk of the Course. It is recommended that a Rider Liaison Officer should hold at least a Regional Clerk of the Course licence. It is also strongly recommended that a Rider Liaison Officer is appointed by the organising club when staging higher status events (e.g. National Championships/British Masters and International permitted events). In this situation the Rider Liaison Officer must hold an ACU National Clerk of the Course licence.

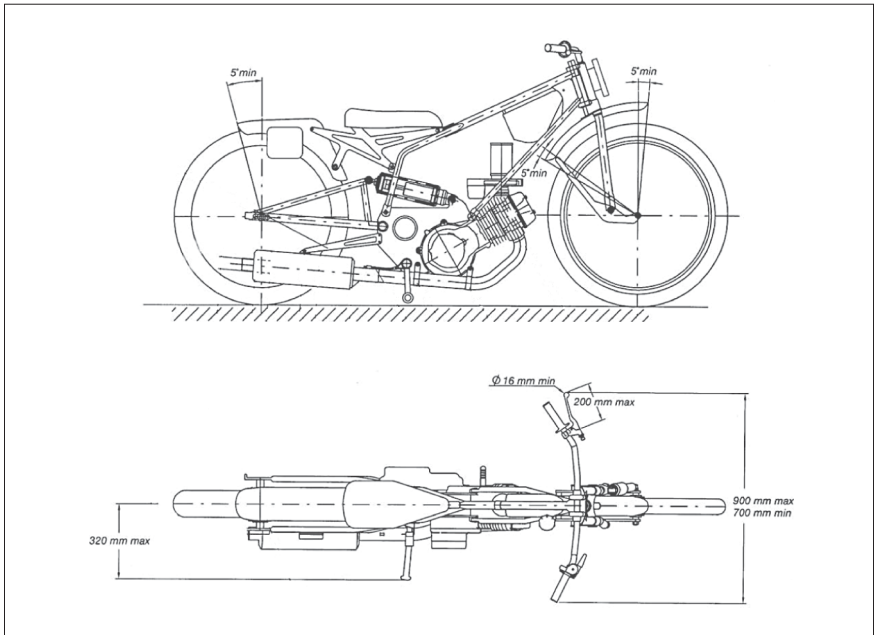

Track racing motorcycle

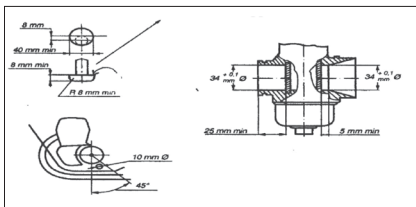

500cc solo only

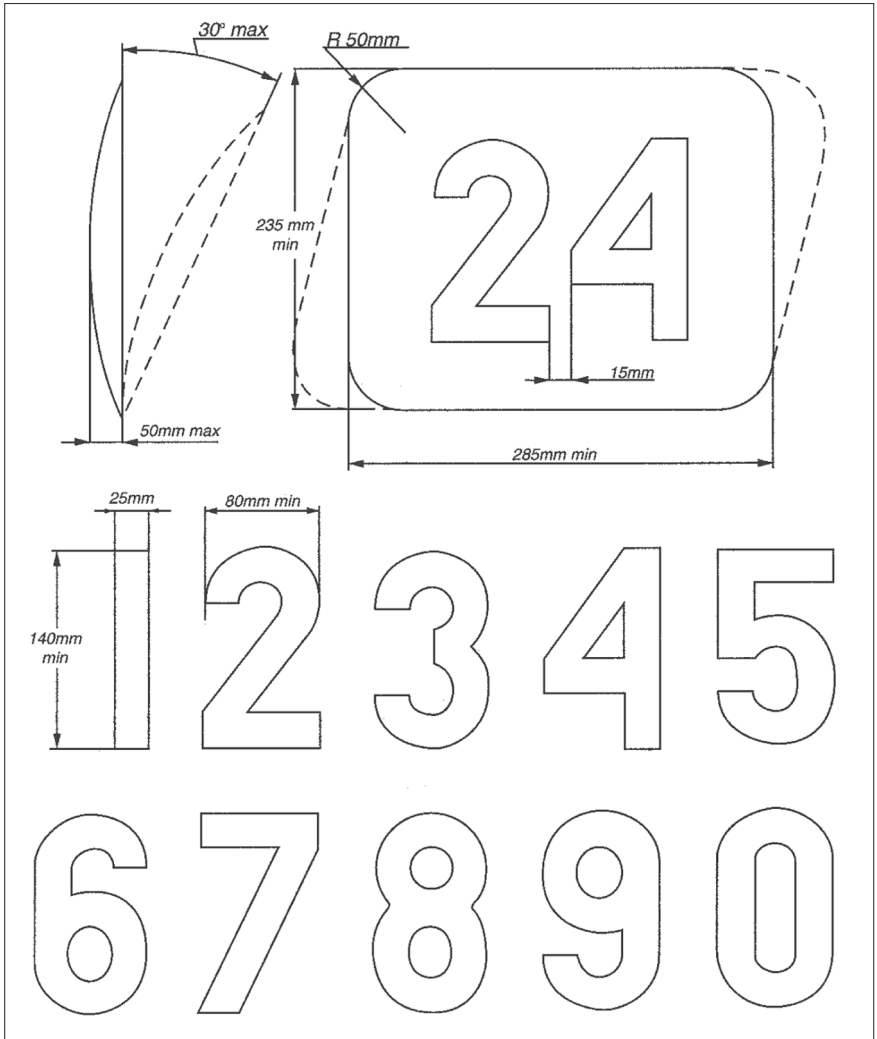

Road Racing

Standing Regulations

SECTION 1 MEETINGS

1.1	Categories of Meetings	241
1.2	International	241
1.3	European Open	241
1.4	National	241
1.5	Open	241
1.6	Restricted	241
1.7	Eligibility of Foreign Riders in Open and Restricted Meetings	242
1.8	Practice Meetings and Test Days	242
1.9	Conditions for Road Race Meetings	242
1.10	Force Majeure	242
1.11	Motorcycle Groups	242
1.12	New Application for a Track Licence for closed Public Roads	242

SECTION 2 LICENCES – COMPETITORS

2.1	General	243
2.2	Grades	243
2.3	Lapsed Licences	244
2.4	Capacity and Licence Restrictions	244
2.5	Racing on Closed Public Roads	245
2.6	Isle of Man Mountain Course Licence	245

SECTION 3 LICENCES AND REGISTRATIONS – OFFICIALS

3.1	Qualifications and Conditions	247
3.2	Road Race Officials who require a Licence	247
3.3	Grades for Clerk of the Course	247
3.4	Road Race Officials who do not require a Licence	248

SECTION 4 PRACTICE

4.1	Time must be put aside for the practice sessions and these must be defined in the Supplementary Regulations for the meeting.	249
------------	--	------------

SECTION 5 GRID POSITIONS

5.1	Positions	249
5.2	Timed Practice	249
5.3	Balloted	249
5.4	Allocated	249

SECTION 6 START PROCEDURES

6.1	Group Starts	249
6.2	Interval Starts	249
6.3	Clubmans Races	250
6.4	National Races	250
6.5	Anticipation of the Start	251

SECTION 7 FLAGS AND LIGHTS

7.1	Flags and Lights used to provide Information	251
7.2	Flags used to convey Information and Instructions	252
7.3	Flag Dimensions	254

7.4	Flag Colours	254
7.5	Flag Marshals Posts	254

7.6	Marshals Overalls	254
-----	-------------------	-----

SECTION 8 BEHAVIOUR DURING PRACTICE AND RACE

8.1	Riders must obey the flag signals, the light signals, and the boards	254
8.2	Protests	255

SECTION 9 NEUTRALISATION OF RACES – SAFETY CAR 256

SECTION 10 INTERRUPTION OF A RACE 257

SECTION 11 RE-STARTING A RACE THAT HAS BEEN INTERRUPTED 257

SECTION 12 FINISH OF A RACE AND RACE RESULTS

12.1	Finish of a Race	257
12.2	The Chequered Flag	258
12.3	Race Results	258

SECTION 13 SAFETY

13.1	Medical Services – Minimum requirements for Road Race Meetings	258
13.2	Track Safety Precautions	260
13.3	Fire Extinguishers	260
13.4	Fire Extinguishers at Circuits	261
13.5	Warning and Prohibition Signs at Circuits	261
13.6	Declaration – Admission Tickets, Armbands and Passes	261
13.7	Declaration on the Official Programme	262
13.8	Signing On	262

SECTION 14 GENERAL TECHNICAL SPECIFICATIONS

14.1	Protective Clothing	262
14.2	Helmets	263
14.3	Identification Discs	263
14.4	Body Jewellery	263
14.5	Engine and Frame Numbers	263
14.6	Fuel	263
14.7	Number Plates	263
14.8	Control of Exhaust Sound Level	265
14.9	Exhaust Pipes	266
14.10	Superchargers/Turbochargers	266
14.11	Handlebars	267
14.12	Clutch and Brake Levers	267
14.13	Mudguards	267
14.14	Open Transmission Guards	267
14.15	Footrests	267
14.16	Oil Supply Pipes	268
14.17	Oil Catch Tanks & Breather Systems	268
14.18	Petrol and Oil Filler Caps	268
14.19	Petrol Tank Breathers	268
14.20	Construction	268
14.21	Additives to Water in Radiators	268
14.22	Brakes	268
14.23	Transponders	268

14.24	Technical Control	269
14.25	Technical Protest	269

SECTION 15 SOLO SPECIFICATIONS

15.1	Size of Wheel Rims and Tyres	270
15.2	Type of Tyres including the use of Slick Tyres in Club Meetings	270
15.3	Treaded Tyres	270
15.4	Tubeless Tyres	270
15.5	Slick Tyres	270
15.6	Streamlining	270
15.7	Inclination	271
15.8	Brakes	271
15.9	Oil Containment	271
15.10	Red Rear Warning Lights	272

SECTION 16 SOLO ELIGIBILITY SPECIFICATIONS

16.1	ACU Production Classes	272
16.2	Formula Specifications	273
16.3	ACU Supersport Regulations	273
16.4	ACU/FIM Specifications for Superbike	273
16.5	ACU Stocksport/Superstock Regulations	273
16.6	ACU Superstock 600	273

SECTION 17 SIDECAR SPECIFICATIONS

17.1	GROUPS B1 AND B2 – General	273
17.2	GROUP B3 (CYCLECARS) – General	275
17.3	GROUP B1, B2 and B3 Technical Specifications	276

SECTION 18 OPEN 600 AND FORMULA II SIDECAR SPECIFICATIONS

18.1	Engine Types	278
18.2	General Construction	278
18.3	Engine Position	279
18.4	Dimensions	279
18.5	Streamlining and Bodywork	280
18.6	Passenger Platform	280
18.7	Air Intakes	280
18.8	Oil and Coolant Containment	280
18.9	Airbox	281
18.10	Oil Catch Tanks	281
18.11	Wheels	281
18.12	Steering	282
18.13	Throttle Controls	282
18.14	Control Levers	282
18.15	Brakes	282
18.16	Tyres	282
18.17	Mudguards and Wheel Protection	282
18.18	Exhaust Pipes	282
18.19	Fuel Tank	283
18.20	Battery	283
18.21	Cut out Device	283
18.22	Red Warning Light	283

18.23	Traction Control	283
18.24	Rear View Mirror	283

SECTION 19 FORMULA 1 SIDECAR SPECIFICATION

19.1	Engine Specifications	284
19.2	Engine	284
19.3	Dimensions	285
19.4	Steering	285
19.5	Suspension	285
19.6	Wheel Protection	285
19.7	Exhaust	285

SECTION 20 PARADES AT ACU/MCRCB ROAD RACE MEETINGS

20.1	Introduction	285
20.2	Organisation	285
20.3	PR5 Spectator Parades – Speed Controlled	286
20.4	PR6 Classic Machine and/or Rider Parades	287

SECTION 21 ORGANISATION OF OFFICIAL TEST DAYS

21.1	Organisation	289
21.2	Insurance	289
21.3	Medical Cover	289
21.4	Officials	289
21.5	Riders	289
21.6	Junior Riders	289
21.7	Technical Control	290
21.8	On Circuit Control	290
21.8	Road Race Motorcycle	291
21.9	Circuit	290

SECTION 1 MEETINGS

1.1 CATEGORIES OF MEETINGS

- International Meetings
- European Open Meetings
- National Meetings
- Open Meetings
- Restricted Meetings

Permits for all Road Race competitions are issued by ACU Headquarters.

1.2 INTERNATIONAL

1. The Permit shall be issued by the ACU Headquarters for a meeting inscribed on the International Calendar of the FIM and having an FIM International Meeting Number (IMN).
2. An International meeting is open to Entrants and Riders of more than one nation who must hold an International Licence or a National Licence issued by the ACU valid for the particular meeting concerned.
3. All riders not holding a Licence issued by the ACU or SACU must carry proof of Insurance and a written Start Permission document issued by their FMN.

Note: This includes all riders holding a licence issued by the MCUI.

1.3 EUROPEAN OpEN

1. The permit shall be issued by ACU Headquarters for a meeting inscribed on the Calendar of the Fédération Internationale de Motocyclisme Europe (FIME) and having a European Meeting Number (EMN).
2. A European Open meeting is open to Entrants and Riders of more than one European nation who must hold the appropriate Competition Licence valid for the particular meeting concerned.
3. All riders not holding a Licence issued by the ACU or SACU must carry proof of Insurance and a written Start Permission document issued by their FMN.

Note: This includes all riders holding a licence issued by the MCUI.

1.4 NATIONAL

1. The Permit shall be issued by the ACU Headquarters.
2. A National meeting is open to Entrants and Riders who are the holders of a National or International Licence valid for the particular meeting concerned issued by any Federation.
3. All riders not holding a Licence issued by the ACU or SACU must carry proof of Insurance and a written Start Permission document issued by their FMN.

Note: This includes all riders holding a licence issued by the MCUI.

1.5 OpEN

1. An Open permit is issued by ACU Headquarters.
2. An Open meeting is open to Entrants and Riders who hold a valid ACU or SACU Licence for the meeting concerned.

1.6 RESTRICTED

1. A Restricted Permit is issued by ACU Headquarters.
2. A Restricted meeting is open to Entrants and Riders who hold a current ACU or SACU Licence valid for the meeting concerned.
3. The Supplementary Regulations issued for the event must specify all restrictions and requirements of eligibility.

1.7 ELIGIBILITY OF FOREIGN RIDERS IN OPEN AND RESTRICTED MEETINGS

1. The Supplementary Regulations issued for the event must specify the licence qualification and eligibility requirements of foreign riders.
2. All riders must have a current Licence and Start Permission from their own Federation valid for the event.

1.8 PRACTICE MEETINGS AND TEST DAYS

1. Permits for Practice Meetings and Test Days may be issued on application to the Permit Issuing Authority.
2. No such event may be held unless the appropriate Permit and Insurance has been issued.

1.9 CONDITIONS FOR ROAD RACE MEETINGS

1. The ACU Road Race Committee must approve the Organiser.
2. The Venue must hold a current Track Licence or Track Certificate issued by the ACU Road Race Committee.
3. The ACU Secretariat must approve the Supplementary Regulations for the event and issue an ACU Permit prior to publication and circulation.
4. For all ACU Championships an ACU decal, supplied by the ACU Secretariat, must be displayed on each machine. Any rider not complying will be disqualified from the results of the race.
5. The Race Control must remain operative with all equipment in place until the end of the period provided for the lodging of a protest, and all officials and marshals must remain at the circuit and available to the Clerk of the Course and the Stewards during that period.

1.10 FORCE MAJEURE

The Clerk of the Course has the right to alter, abandon, cancel or postpone all or any part of a meeting for reasons of force majeure. Such a decision shall not be subject to any protest.

1.11 MOTORCYCLE GROUPS

For Racing purposes machines from Group A1, Group A2 and Group A3 should not be mixed on track to Race at the same time.

1.12 NEW APPLICATION FOR A TRACK LICENCE FOR CLOSED PUBLIC ROADS

All applications for Track Licences for closed Public Roads will only be approved once the organisers can show evidence that they have the facilities to provide suitable protection. A suitable risk assessment for spectators must be supplied and demonstrate that appropriate Prohibited and Restricted areas for spectators can be enforced and maintained during practice and racing.

They must have the approval of the land owners and have the right to close the public roads for racing to take place.

The maximum capacity solo machine will be restricted to 600cc four stroke or 650cc twins.

Sidecars will not be permitted in the first year, but may be permitted in future years with special permission of the Road Race Committee.

All such applications must include a map (to scale) of the roads to be raced together with the Prohibited and Restricted Areas and written consent of all the landowners/tenants involved.

A written Risk Assessment for Spectators and Riders must be submitted at least 30 days prior to any Track Inspection taking place.

SECTION 2 LICENCES – COMPETITORS

2.1 GENERAL

1. To participate in road race events an annual Licence issued by the ACU is required. Residents in Scotland apply to the Scottish ACU.
2. All first time applicants are required to complete a classroom based ACU Competitor Training Course. Riders and Sidecar Drivers must also satisfactorily complete an ACU Basic Rider Assessment. Full details from the ACU Road Race Department. First time applicants for an ACU Road Race Parade Licence must hold a current Full Class "A" DVLA motorcycle licence or must satisfactorily complete an ACU Road Race Basic Rider Assessment
3. Novice/Intermediate Novice competitors are required to wear an Orange Vest obtainable from the ACU Licence Department.
4. Sidecar passengers must hold a valid passenger licence.
5. The parent or Legal Guardian must accompany all competitors, or participants in parades, under 18 years of age to every meeting. This person must attend at signing-on, any riders briefings that take place and be present throughout the meeting.
6. Any competitor who in any ACU or MCRCB Permitted Event participates on a machine for which he/she is not eligible through age or licence restrictions to take part on will be penalised by a fine of £500.00 and a suspension for one year from the date of the hearing.

2.2 GRADES

1. **Parade.** A licence facilitating participation in non-competitive parades.
2. **Novice.** Entry level for all first time applicants, an Intermediate Novice licence will be issued to riders who hold a current Full Class "A" DVLA Licence. Novice Licence holders are required to wear an Orange Vest obtainable from the ACU Licence Department.
3. **Clubman.** Novice/Intermediate Novice licence holders who have obtained Satisfactory signatures on their record card for a minimum of 10 separate Race Days at 3 different circuits during the current year and preceding 2 years may apply to upgrade to Clubman. To obtain a satisfactory signature Competitors must appear in the official race results as a finisher of a race in accordance with Article 12.3.3 of the Road Race Standing Regulations. Only one signature per race day. The competitor record card together with copies of the official result sheets for the signatures should be submitted to the ACU Road Race Department.
4. **National.** Clubman competitors who have obtained upgrade signatures for a minimum of 10 separate Race Days at 3 different circuits during the current year and preceding 2 years may apply to be upgraded to a National Licence. To obtain an upgrade signature Competitors must appear in the official result sheets as having finished the race and have an average race speed equal to or greater than 92.5% of their respective CLASS winner. Only one signature per race day will be awarded with the exception of results from Endurance meetings. Where a rider competes in an Endurance race of 3 hrs or more duration 2 signatures will be awarded if the Team completes at least 90% of the number of laps completed by the Race/Class winner. The competitor record card together with copies of the official result sheets for the signatures should be submitted to the ACU Road Race Department. National Licence holders may apply for Start Permission to compete abroad.
5. **International** National licences holders who have held their National Licence for 12 months and who have competed at a minimum of 6 meetings in the previous 12 months may apply for an FIM Non-Championship International licence. The Competitor record card and copies of result sheets should be submitted to the ACU Road Race Department. A satisfactory medical examination is required before an FIM Non-Championship International licence can be issued (Eye Sight and Medical Report sections of the ACU Competition Licence Application Form).

6. **International Championship** National licences holders who have held their National Licence for 12 months and who have competed at a minimum of 6 meetings in the previous 12 months may apply for a Championship licence as described in the appropriate Sporting Code of the FIME or FIM. The Competitor record card and/or copies of result sheets should be submitted to the ACU Road Race Department. A satisfactory medical examination is required before an International Championship Licence can be issued (Eye Sight and Medical Report sections of the ACU Competition Licence Application Form).
7. A Licence can be upgraded at any time during the year.

2.3 LAPSED LICENCES

Lapsed Novice and Intermediate Novice Licence holders who have allowed their licence to lapse for five years or more (missed 5 or more seasons racing) will be required to complete the Basic Rider Assessment and Competitor Training Course before resuming competition at Novice/Intermediate Novice grade.

Lapsed Clubman, National and International licence holders who have allowed their licence to lapse for five years or more (missed 5 or more seasons racing) will be required to complete the Competitor Training Course before resuming competition at Clubman grade.

2.4 CAPACITY AND LICENCE RESTRICTIONS

SOLO MACHINES

Age	Licence	Machine
11 Years	Novice or Clubman or National	Up to 125cc Automatic Production Scooter
12 years	Novice or Clubman or National	Up to 80cc GP specification machine (treaded tyres) Up to 125cc Production based machine Up to 250cc single cylinder 4 stroke Production machines (restricted)
13 Years	Novice or Clubman or National	Up to 125cc Automatic Production Scooter Up to 80cc GP specification machine Up to 125cc Production based machine Up to 305cc single or twin cylinder 4 stroke Production machines (restricted to maximum 37hp) Up to 390cc Single cylinder 4 stroke Production machine (restricted) Aprilia RRV450-R (Restricted) Kawasaki Ninja 400, (restricted to maximum 37hp)
13 years	National	Up to 125cc GP specification machine Up to 250cc 4-stroke single cylinder machine (unrestricted)
14 years	Novice or Clubman or National	Up to 125cc GP specification machine Up to 250cc 4-stroke single or twin cylinder machine (unrestricted)
14 years	National	Up to Formula 400 specification or 450cc Production based machine Up to 500cc single or twin cylinder 4-stroke machine Up to 650cc twin cylinder 4-stroke Production based machine
15 years	Novice or Clubman or National	Up to Formula 400 specification or 450cc Production based machine Up to 500cc single or twin cylinder 4-stroke machine Up to 650cc single or twin cylinder 4-stroke Production based machine

16 years	Novice or Clubman or National	Up to Formula 400 specification or 450cc Production based machine Up to 500cc single or twin cylinder 4-stroke machine Up to 650cc single or twin cylinder 4-stroke Production based machine
16 years	National	Any classic or Vintage machine up to 650cc Up to Formula 600 or Supersport 600 specification machine 675cc 3 cylinder 4 stroke Production based machine Up to 250cc Grand Prix Machine
17 years	Novice or Clubman or National	Any classic or Vintage machine up to 650cc Up to Formula 600 or Supersport 600 specification machine 675cc 3 cylinder 4 stroke Production based machine Up to 250cc Grand Prix Machine
17 years	National	Unlimited capacity machine
18 years	Novice	Any classic or Vintage machine 650cc Up to Formula 600 or Supersport 600 specification machine 675cc 3 cylinder 4 stroke Production based machine Up to 250cc Grand Prix Machine
18 years	Int-Novice** Clubman or National	Unlimited capacity machine

***Intermediate Novice Licence holder with "A" validation for riders holding a Full Class "A" DVLA Licence*

SIDECAR AND THREE-WHEELER MACHINES

Age	Licence	Machine
Driver		
17 years	Novice or Clubman or National	F1, F2, F350, Classic, Vintage, Morgan Three Wheeler Unlimited 4-stroke or 2-stroke machine
Passenger		
16 Years	Novice or Clubman or National	F1, F2, F350, Classic, Vintage, Morgan Three Wheeler Unlimited 4-stroke or 2-stroke machine

PARADE

Age	Licence	Machine
14–70 years	Single Grade	All Classes

2.5 RACING ON CLOSED PUBLIC ROADS

The minimum grade of licence required for racing on Closed Public Roads is a National Licence and riders must be 18 years of age or over.

2.6 ISLE OF MAN MOUNTAIN COURSE LICENCE

An Isle of Man Course Licence (price £25 in addition to any other Licence Fee) issued by the ACU Road Race Department – Rugby is required for all competitors of any Nationality wishing to take part in any event to be held on the Isle of Man Mountain Circuit.

In addition to an Isle of Man Mountain Course Licence, all Newcomers to the Course must take part in prescribed Newcomers Training held on the Isle of Man prior to the event.

1 2020 Isle of Man TT Races

This licence is a requirement for all competitors who wish to take part in the 2020 Isle of

Man TT Races.

1. All applicants must provide a satisfactory medical report.
2. All Competitors must have held a National licence for Road Racing for a minimum of 12 months prior to the closing date for entries.

3. Official Result sheets confirming the following requirements must be supplied with the application:
 1. All applicants must have competed satisfactorily in at least 6 Road Race days in the period of 30th March 2019 to 1st May 2020.
 2. A minimum of 2 of the 6 required race days must be in the 2020 season.
 3. In exceptional cases Test Days may be taken into consideration. For a Test Day to be considered as one day, participants must complete a minimum of 50 laps during the Test Day.
 4. For all Competitors 3 of the 6 required race results must show the rider as having finished the race and have an average race speed equal to or greater than 92.5% of their respective CLASS winner. (ACU National licence upgrade qualifying criteria).
 5. One result will be permitted from each racing day of a short circuit Road Race Meeting to a maximum of 2 per meeting.
 6. One result will be permitted from each racing day of a Closed Public Road Race circuit meeting to a maximum of 2.
 7. Qualifying for the 2019 TT or Manx GP/Classic TT Races will count as one race day and finishing in a 2019 TT or Manx GP/Classic TT Race will count as a second race day. A competitor who competes in both the TT and Manx GP/Classic TT Race may count a maximum of three results towards the six required results.
4. Closing date for the receipt of completed Licence application forms at ACU House, Rugby: 8th May 2020.

2 2020 Manx Grand Prix and Classic TT Races

This licence is a requirement for all competitors who wish to take part in the 2020 Manx Grand Prix/Classic TT races.

1. All applicants must provide a satisfactory medical report.
2. ACU and SACU licence holders must have held a National licence for Road Racing for a minimum of twelve months prior to the first day of practising.
3. Official Result sheets confirming the following requirements must be supplied with the application:
 1. All applicants must have competed satisfactorily in at least 6 Road Race days in the 13 months expiring 28th June 2020.
 2. A minimum of 2 of the 6 required race days must be in the 2020 season.
 3. In exceptional cases Test Days may be taken into consideration. For a Test Day to be considered as one day, participants must complete a minimum of 50 laps during the Test Day.
 4. For all Competitors 3 of the 6 required race results must show the rider as having finished the race and have an average race speed equal to or greater than 92.5% of their respective CLASS winner. (ACU National licence upgrade qualifying criteria)
 5. One result will be permitted from each racing day of a short circuit Road Race meeting to a maximum of 2 per meeting.
 6. One result will be permitted from each racing day of a Closed Public Road circuit meeting to a maximum of 2.
 7. Qualifying for the 2019 TT or Manx GP/Classic TT Races will count as one race day and finishing in a 2019 TT or Manx GP/Classic TT Race will count as a second race day. A competitor who competes in both the TT and Manx GP/Classic TT Races may count a maximum of three results towards the six required results.
4. Closing date for the receipt of completed Licence application forms at ACU House, Rugby: 6th July 2020.

SECTION 3 LICENCES AND REGISTRATIONS – OFFICIALS

3.1 QUALIFICATIONS AND CONDITIONS

Road Race Officials are divided into two categories: Those that are Licensed and those that are Registered.

Licences: Senior Road Race Officials are required to hold an ACU Licence of the appropriate Grade for the performance of their duties.

Registration: A Register is maintained of Officials not required to hold a Licence.

3.2 ROAD RACE OFFICIALS WHO REQUIRE A LICENCE

All the following licences are valid for 3 years.

	See Note Below	Attendance at Seminar/Training Session
Clerk of the Course	1	Every third year maximum
Chief Steward	2	Every third year maximum
Chief Technical Officer	3	Every third year maximum
Sound Inspector		Required for First Issue only
Measurer	4	Required for First Issue only
Timekeeper		Equipment and operators check

ALL LICENCES ISSUED ARE SUBJECT TO THE APPROVAL OF THE ROAD RACE COMMITTEE

Organisers shall only nominate candidates whose aptitude and integrity for the position they can fully justify. Official ACU approval and the issue of a Licence is only after the candidates have proved to be competent according to the special requirements for each discipline. The respective Committees and Panels organise Seminars that are compulsory for certain Officials.

3.3 GRADES FOR CLERK OF THE COURSE

1. Probationary

Any Organiser may nominate a Probationary Clerk of the Course. The Organiser must be able to confirm that a candidate has attended at 10 Race Days in an Official capacity before

nominating the candidate to attend a Seminar. A Registered Probationary Official may act as an Assistant to a Clerk of the Course at a Club Event.

To upgrade from Probationary to National C a registered official must act as an Assistant to the Clerk of the Course at 10 Meetings and be recommended by the Clerk of the Course at each meeting. He must be nominated by an Organiser for a specific appointment at a future Event.

2. National Grade C

A Clerk of the Course who may officiate at a Club Event where the use of slick tyres has NOT been authorised. May act as Deputy or Assistant Clerk of the Course at below National status Events where slick tyres have been authorised.

To upgrade from National C to National B a licence holder must officiate as a Deputy to a National A or National B Clerk of the Course at 10 Events and be recommended by the Clerk of the Course at each. He must be nominated by an Organiser to take charge of a specific event where he will be observed by another Senior Official nominated by the Road Race Committee.

3. National Grade B

A Clerk of the Course who may officiate at a below National status events where slick tyres HAVE been authorised. May officiate as Deputy to a National Grade A.

To upgrade from National B to National A a Licence holder must officiate as a National B Clerk of the Course at 5 Events. He must act as Deputy to a National A Clerk of the Course at 5 Events and be recommended by the Clerk of the Course at each. In addition the Road Race, Drag and Sprint Committee may appoint a Senior Official to observe him. He must be nominated by an

Organiser to take charge of a specific future Event. First appointment must be approved by the Road Race Committee.

4. National Grade A

A Clerk of the Course who may officiate at any event held under an ACU Permit. He may officiate as Deputy or Assistant at FIM (Non Championship) Events.

Note 1 Clerk of the Course

Age Limits: Licences for Clerks of the Course who have attained their 70th birthday will be reviewed annually. Officials will be required to satisfactorily attend a seminar annually. The issuing of a licence will be subject to Road Race Committee approval.

Note 2 Steward

Grades: There is only one grade of Chief Steward's Licence for all Road Race disciplines. A Chief Steward of a meeting should not undertake any other duties except Environmental Reporting.

Age Limits: Chief Stewards may not normally officiate beyond the end of the season in which they attain their 70th birthday. The Road Race, Drag and Sprint Committee will review Stewards who reach the age of 70 for appointments on an annual basis.

Club Stewards may carry out other duties at a race meeting but they must not adjudicate on matters where they have a conflict of interest.

Note 3 Chief Technical Officer

The Chief Technical Officer will be licensed by the Technical Panel to be in charge of the Technical Control at an event. The Technical Panel may restrict the disciplines of licence holders.

Note 4 Measurer

The Measurer is required for ACU National Championships and National events. The Licence is issued by the Technical Panel and may be restricted by discipline.

Licence Fees: All licences will be issued, free of charge, for a period of three years. No fee will be charged for attendance at Seminars organised by the Road Race Drag and Sprint Committee or the relevant Panel with the exception of FIM Seminars.

3.4 ROAD RACE OFFICIALS WHO DO NOT REQUIRE A LICENCE

See Note Below Attendance at Seminar/Training Session

Incident Officer	1	Refer to Note 1.
Secretary of the Meeting	2 and 4	Will receive Training at meetings and if required at Regional or ACU HQ Seminars.
Technical Official		Will receive training via the Chief Technical Officer at meetings May attend Regional Training Seminars
Club Stewards	3	May attend Regional or ACU HQ Seminars for information purposes
Chief Marshal		May receive training at ACU HQ or Regional Training Days
Marshal		May receive training at Regional Training days and at meetings via the Chief Marshal
Medical Officer		None required

Registration of the above officials and marshals will be renewed annually. All such Officials will receive an appropriate form of identification from the ACU.

Note 1

For 2019 it is recommended that the Incident Officer is at least a Probationary Clerk of the Course or has attended an Incident Officer Seminar.

For 2020 and onwards the Incident Officer will be required to hold at least a Probationary Clerk of the Course licence or have attended an Incident Officer Seminar.

Note 2 Secretary of the Meeting

Will be responsible for all administration connected with the organisation of a meeting.

Note 3 Club Stewards

Stewards of the meeting exercise judicial authority over the running of the meeting according to the National Sporting Code and Supplementary Regulations.

Note 4 Secretary of the Meeting Registration

Currently there is no requirement for the Secretary of the Meeting to be registered for Road Race Disciplines.

SECTION 4 PRACTICE

4.1 TIME MUST BE PUT ASIDE FOR THE PRACTICE SESSIONS AND THESE MUST BE DEFINED IN THE SUPPLEMENTARY REGULATIONS FOR THE MEETING.

1. Riders will commence practice under the instructions of the Start Officials.
2. The duration of each practice session will commence from the time the pit lane opens and will finish (chequered flag) not less than 10 minutes later.
3. The end of practice will be indicated by the waving of a chequered flag at which time the pit exit will be closed. A rider's time will continue to be recorded until he passes the finish line after the allotted time has lapsed.
4. If practice is interrupted due to an incident or any other reason then a red flag will be displayed at the start line and at marshals posts. All riders must return slowly to the pit lane or as otherwise instructed by the Marshals under the direction of the Clerk of the Course.
5. When the practice is restarted the time remaining will be decided by the Clerk of the Course.

SECTION 5 GRID POSITIONS

5.1 POSITIONS

1. Pole position, and the configuration of the grid, will be determined at the time of the Track Inspection.
2. Grid positions will be established according to the provisions of the Supplementary Regulations.

5.2 TIMED PRACTICE

Where timed practice is used and identical times are recorded by more than one rider in the official qualifying practice session for the race the rider first setting such a time will receive the better starting position.

A qualifying maxima may be specified in the Supplementary Regulations.

5.3 BALLOTTED

Where the Organiser decides that the grid positions will be by ballot, this must be conducted by the competitors at the meeting.

5.4 ALLOCATED

Organisers wishing to allocate grid position will specify this and the method to be adopted in the Supplementary Regulations.

SECTION 6 START PROCEDURES

Races may be started by one of the following methods:

6.1 GROUP STARTS

Which include the 45 degree echelon line up known as the Le Mans start.

6.2 INTERVAL STARTS

Where competitors are started individually or in groups at pre-determined intervals.

Starts may be made with engines running or engines stopped. For starts with engines stopped the Supplementary Regulations for the race must specify the authorised method of starting.

6.3 CLUBMANS RACES

1. Riders collect in the Assembly Area and proceed when directed to the Grid to take up their allocated Grid positions.
2. An Official will signal all the Riders to proceed on a warm-up lap (of the circuit being used for the race) by waving a Green Flag. On completion of the warm-up lap the riders each return to their allocated Grid positions.
3. Riders who do not go on to the Grid may join the warm-up lap from the Pit Lane on the instruction of the Officials, but in this case must start the race from the back of the Grid.
4. On the completion of the warm-up lap an Official will display a Red Flag at the front of the Grid.
5. When the grid is re-formed the Official with the Red Flag will leave the Grid indicating to the Riders that the race is about to commence.
6. Any Rider who stalls his engine on the Grid, or who has other difficulties, must remain on his motorcycle and raise an arm. It is not permitted to attempt to delay the start by any other means.
7. A Red light will be displayed for up to 5 seconds. The Red Light will then be extinguished to start the race. Alternatively, the National Flag may be lowered to start the race.
8. After the Riders have passed the exit of the Pit Lane any Riders waiting there may be permitted to join the race at the discretion of the Clerk of the Course and under the instructions of the Officials.
9. Should there be a problem on the Grid, the Starter may display a Yellow Flag or Yellow lights to indicate a delayed start. The Clerk of the Course may decide that the Riders will complete another warm-up lap and the race distance may be reduced.

6.4 NATIONAL RACES

1. Riders proceed as directed to the Grid upon the opening of the Pit Lane and take up their starting positions.
2. Riders take up their allocated positions on the Grid. Riders who encounter technical problems must go to the Pit Lane to make adjustments or to change machines.
3. Two minutes before the start of the race the Starter will signal all the Riders to proceed on a warm-up lap by waving a Green Flag. On completion of the warm-up lap the riders each return to their allocated Grid positions.
4. Riders not going on to the Grid may join the warm-up lap from the Pit Lane on the instructions of the Officials but in this case must start the race from the rear of the Grid.
5. On completion of the warm-up lap an Official will display a Red Flag at the front of the grid.
6. When the Grid is re-formed the Official with the Red Flag will leave the track indicating to the Riders that the race is about to commence.
7. Any Rider who stalls his engine on the Grid or who has other difficulties must remain on his motorcycle and raise an arm. It is not permitted to delay the start by any other means.
8. A Red Signal light will be displayed for up to 5 seconds. The Red Light will then be extinguished to start the race. Alternatively, the National Flag may be lowered to start the race.
9. After the Riders have passed the exit to the Pit lane any Riders waiting there may be permitted to join the race at the discretion of the Clerk of the Course and under the instructions of the Officials.
10. Should there be a problem on the Grid, the Starter may display a Yellow Flag or Yellow lights to indicate a delayed start. Riders will stop engines. One assistant per team may enter the grid to assist the competitors. The Rider(s) responsible for the delay will start from the back of the

Grid. The Riders will complete another warm-up lap and the race distance will be reduced by one lap.

6.5 ANTICIPATION OF THE START

1. Anticipation of the Start is defined as when the motorcycle is moving forward when the Red Lights are on.
2. Any Competitor who takes up an incorrect Grid position will be judged to have anticipated the Start.
3. The Clerk of the Course will award a Time Penalty of up to 20 seconds to any Rider who anticipated the Start. The decision as to an anticipated Start is to be accepted as a Matter of Fact from which there is no right of Protest.

SECTION 7 FLAGS AND LIGHTS

Marshals and other officials display flags or lights to provide information and/or convey instructions to the riders:

7.1 FLAGS AND LIGHTS USED TO PROVIDE INFORMATION

1. NATIONAL FLAG OR START LIGHTS

1. Signal for the Start of the Race. A Red light will be displayed for up to 5 seconds. The Red Light will then be extinguished to start the race. Alternatively, the National Flag may be lowered to start the race.

2. GREEN FLAG

1. The track is clear.
2. This flag will be shown waved by the starter to signal the start of the warm up lap.
3. This flag must be shown motionless at each flag marshal post for the first lap of each practice session and of the warm up, for the sighting lap(s) and for the warm up lap.
4. This flag must be shown motionless at the flag marshal post immediately after the incident that necessitated the use of one or more yellow flags.

3. YELLOW AND RED STRIPED FLAG

1. Oil, water or other substance is affecting adhesion on this section of the track.
2. This flag must be shown motionless at the flag marshal post.

4. YELLOW AND RED STRIPED FLAG: NATIONAL EVENTS ONLY

1. The adhesion on this section of the track could be affected by any reason other than rain.
2. This flag must be shown motionless at the flag marshal post.

5. WHITE FLAG WITH DIAGONAL RED CROSS: NATIONAL EVENTS ONLY

1. Drops of rain on this section of the track.
2. This flag must be shown motionless at the flag marshal post.

6. WHITE FLAG WITH DIAGONAL RED CROSS + YELLOW AND RED STRIPED FLAG:

NATIONAL EVENTS ONLY

1. Rain on this section of the track.
2. These flags must be shown together motionless at the flag marshal post.

7. BLUE FLAG

1. National events and above. The use of this flag is optional at meetings of lower than National Status.
2. May be shown waved, this flag indicates that a faster rider is about to overtake.
3. Shown waved at the flag marshal post, this flag indicates to a rider that he is about to be overtaken.
4. During the practice sessions, the rider concerned must keep his line and slow down gradually to allow the faster rider to pass him.
5. During the race, the rider concerned is about to be lapped. He must allow the following rider(s) to pass him at the earliest opportunity.

8. YELLOW FLAG WITH BLACK DIAGONAL CROSS

1. This flag will be shown motionless at the finish line at track level to indicate the commencement of the final lap of the race.

9. CHEQUERED BLACK AND WHITE FLAG

1. This flag will be waved at the finish line on track level to indicate the finish of race or practice session.

10. CHEQUERED BLACK AND WHITE FLAG PLUS BLUE FLAG

1. The chequered black/white flag will be waved together with the blue flag presented motionless at the finish line on track level when a rider(s) precedes closely the leader during the final lap before the finish line.

11. ADDITIONAL FLAGS – THE ISLE OF MAN TT MOUNTAIN COURSE

1. White Flag with Black "V"
Indicates visibility is reduced on the part of the circuit ahead.
2. White Flag with Black "Sun"
Indicates dazzle from the sun on the part of the circuit ahead.

72. FLAGS USED TO CONVEY INFORMATION AND INSTRUCTIONS**1. YELLOW FLAG AND OR YELLOW LIGHTS**

1. During the final inspection lap (by the Stewards and other Officials) this flag must be waved at the exact place where the flag marshal will be positioned during the practices, warm ups and races.
2. Shown waved at each row of the starting grid, this flag indicates that the start of the race is delayed.
3. When shown stationary at the flag marshal post this flag indicates danger ahead, riders must slow down. No overtaking is permitted.
4. When shown waved at the flag marshal post this flag indicates that the danger is more imminent. The riders must be prepared to stop.
5. Overtaking is forbidden up until the point where the green flag is shown.
6. Any infringement of this rule during a practice session will result in the cancellation of the time of the lap during which the infraction occurred.
7. In case of infringement of this rule during the race, a time penalty will be imposed. In both cases, further penalties (such as fine – suspension) may also be imposed.
Note: Following an incident during a practice or race the Yellow Flags are usually displayed as follows:

1. Shown waved at the flag marshals' post immediately prior to the incident.

2. Shown stationary at the flag marshals' post preceding the post at which it is being shown waved.
3. Additional flags may be shown at the request of the Clerk of the Course.

2. WHITE FLAG

1. National events only. Not permitted at Club level.
2. An intervention vehicle is on the track.
3. Waved at the flag marshal post, this flag indicates that the rider will encounter the vehicle in the current section of the track.
4. It is forbidden for a rider to overtake another rider during the display of the white flag.
5. Overtaking the intervention vehicle is permitted.
6. As soon as such a vehicle stops on the track, the white flags must be maintained and the yellow flags must also be presented.

Note: At a meeting of below National status no Ambulance or Fast Intervention Vehicle will be allowed to be moved onto the course or its immediate verges whilst racing or practice is in progress on any part of the circuit. This means that in circumstances when an Ambulance or Fast Intervention Vehicle is required on the circuit, the Red Flags must first be displayed and the race or practice brought to an actual and effective halt before any vehicle is deployed.

3. RED FLAG WITH A WHITE DIAGONAL CROSS. ENDURANCE RACES ONLY.

1. The race is neutralised.
2. Riders must slow down and be prepared to catch up a SAFETY CAR.
3. It is forbidden for a rider to overtake another rider during the display of this flag.
4. Overtaking the SAFETY CAR is forbidden.
5. Riders must line-up in single file behind the SAFETY CAR.
6. This flag must be shown motionless at each flag marshal post,
7. At all meetings where this flag is used a riders briefing must be held.

4. RED FLAG AND RED LIGHTS

1. When the race or practice is being interrupted. On instructions from the Clerk of the Course Red Lights and/or waved Red Flags will be displayed around the circuit. Riders must stop racing/practice and proceed as instructed by the Marshals.
2. Any infringement of this rule will be penalised with one of the following penalties: fine – disqualification – withdrawal of Championship points – suspension.
3. The red flag will be shown motionless on the starting grid at the end of the sighting lap(s) and at the end of the warm up lap.
4. The red flag may also be used to close the track.
5. On the Start Grid a Red Signal Lights(s) will be displayed for up to 5 seconds. When the Red Light(s) are extinguished the race will start.

5. BLACK FLAG

1. This flag is used to convey instructions to one rider only and is displayed motionless together with the rider's number.
2. The rider must stop at the pits at the end of the current lap and cannot restart.
3. Any infringement of this rule will be penalised with one or more of the following penalties: fine – disqualification – withdrawal of Championship points – suspension.

6. BLACK FLAG WITH ORANGE DISK (RADIUS 40cm)

1. This flag is used to convey instructions to one rider only and is displayed motionless together with the rider's number.

2. This flag informs the rider that his motorcycle has mechanical problems likely to endanger himself or others, and that he must immediately leave the track.
3. Any infringement of this rule will be penalised with one or more of the following penalties: fine – disqualification – withdrawal of Championship points – suspension.

7.3 FLAG DIMENSIONS

The flag dimension should be approximately 80cms in the vertical and 100cms in the horizontal.

7.4 FLAG COLOURS

The Pantones for the colours are as follows:

- Orange: Pantone 151C
 Black: Pantone Black
 C
 Blue: Pantone 286C or
 298C Red: Pantone 186C
 Yellow: Pantone Yellow
 CGreen: Pantone 348C

7.5 FLAG MARSHALS POSTS

The position of the Flag Marshals Posts will be fixed during the ACU Track Inspection.

7.6 MARSHALS OVERALLS

It is recommended that Marshals overalls be Orange (Pantone 151C) or white in colour. Waterproofs should be of the same colour or transparent.

SECTION 8 BEHAVIOUR DURING PRACTICE AND RACE

8.1 RIDERS MUST OBEY THE FLAG SIGNALS, THE LIGHT SIGNALS, AND THE BOARDS WHICH CONVEY INSTRUCTIONS. ANY INFRINGEMENT TO THIS RULE WILL BE PENALISED ACCORDING TO THE PROVISIONS OF CHAPTER 7.

1. Riders must ride in a responsible manner which does not cause danger to other competitors or participants, either on the track or in the pit-lane. Any infringement of this rule will be penalised with one of the following penalties:
 fine – time penalty – disqualification – withdrawal of Championship points – suspension.
2. Riders should use only the track and the pit-lane. However, if a rider accidentally leaves the track then he may rejoin it at the place indicated by the marshals or at a place which does not provide an advantage to him. Any infringement of this rule during the practices or warm up will be penalised by the cancellation of the lap time concerned and during the race, by a time penalty. Further penalties (such as fine – disqualification – withdrawal of Championship points) may also be imposed.
3. Any repairs or adjustments along the race track must be made by the rider working alone with absolutely no outside assistance. The marshals may assist the rider to the extent of helping him to lift the machine and holding it whilst any repairs or adjustments are made. The marshal may then assist him to re-start the machine.
4. If the rider intends to retire, then he must park his motorcycle in a safe area as indicated by the marshals.
5. If the rider encounters a problem with the machine which will result in his retirement from the practice or the race, then he should not attempt to tour at reduced speed to the pits but should pull off the track and park his machine in a safe place as indicated by the marshals.
6. Riders are not permitted to return slowly to the pits for any reason during practice or racing.
7. Riders may enter the pits during the race, but taking the motorcycle inside the pit box is not permitted. Any infringement of this rule will be penalised with a disqualification.

- Riders who stop their engines in the pits may be assisted to re-start their motorcycle by the mechanics.
8. Riders are not allowed to transport another person on their machine or to be transported by another rider on his machine.
 9. Riders must adopt a position with their feet on the footrests.
 10. Riders who fall from their machine are not permitted to continue with the practice or race until passed fit by the Medical Officer and the machine re-inspected by technical control. Any infringement of this rule will result in the rider being disqualified from the remainder of the practice session or race and may result in further penalties.
 11. Riders must not ride or push their motorcycles in the opposite direction of the circuit, either on the track or in the pit lane, unless doing so under the direction of an Official.
 12. No signal of any kind may pass between a moving motorcycle and anyone connected with the motorcycle's entrant or rider, save for the signal from the time keeping transponder, or legible messages on a pit board or body movements by the rider. Automatic timing devices, provided they do not disrupt official timekeeping methods, are not considered as telemetry.
 13. The carrying of on board cameras is only permitted with the prior approval, in writing of the Clerk of the Course. The Camera must be securely fitted to the machine. It must not be attached to the body, helmet or clothing of the rider/driver or passenger. The installation of the camera must be approved by the Chief Technical Officer.
 14. A speed limit may be imposed in the Pit Lane.
 1. Any rider found to have exceeded the limit during the practice will be subject to a penalty as described in the Supplementary Regulations.
 2. Any rider who exceeds the pit lane speed limit during a race will be penalised with a time penalty as described in the Supplementary Regulations.
 3. The Clerk of the Course must communicate the offence to the pit of the rider.
 15. In the interest of safety, a rider may not stop his machine on the racing surface during the slow down lap, (exception see Art 8.17) when returning to the pits after the chequered flag.
 16. Stopping on the track during practices and races is forbidden. (exception see Art 8.17)
 17. During the practice sessions and warm ups, practice starts are permitted, when it is safe to do so, at the pit lane exit before joining the track and after the chequered flag is shown at the end of practice sessions and warm ups, when it is safe to do so. These practice starts must take place off the racing line.
 18. The spinning of rear wheels (burn-outs) is strictly forbidden. Breach of this rule will result in a penalty of disqualification.
 19. Any competitor who in any ACU or MRCB Permitted Event participates on a machine for which he is not eligible through age or licence restrictions will be penalised by a fine of £500.00 and a suspension for one year from the date of the hearing.

8.2 **PROTESTS**

1. Any Rider, Passenger, Entrant or Official licensed by the ACU affected by a decision taken during a meeting held under an ACU Permit has the right to protest against that decision.
2. No protest may be lodged against a decision of statement of fact of the Race Direction to inflict or not:
 - A time penalty
 - A change of position
 - A ride through
 - A disqualification from the practice sessions or races by means of a black flag or black flag with orange disc
 - A penalty for speeding in the pit lane.

SECTION 9 NEUTRALISATION OF RACES – SAFETY CAR

A compulsory riders briefing on these Regulations must be conducted by the Clerk of the Course or his Deputy prior to any race in which the use of Safety Cars is intended. The Safety Cars if they are to go on the track must be equipped with Yellow Flashing lights. The words "Safety Car" should be clearly indicated on the back and the sides of the car. The Driver of the Safety Car should be the holder of an ACU or FIM Clerk of the Course or Competition Licence for Road Racing, a MSA Competition Licence or an ARDS Licence. All "Safety Car" drivers must be assisted in the car by a Race Official who is in constant contact with the Clerk of the Course.

If during a race of 20 miles or more an incident other than rain puts at risk the safety of the competitors and renders impossible the normal progress of the competition the Clerk of the Course (Grade National A or above or of Grade National B with the prior individual approval of the Road Race Committee) may decide to neutralize the race.

The following procedure will be adopted:

1. A Red Flag with a White Diagonal Cross must be displayed at the selected Marshals Posts during the whole of the neutralisation period.
2. A White Board showing the words "Safety Car" will be displayed at the Start Line during the whole of the neutralisation period.
3. Riders must immediately slow down. Overtaking is forbidden. The Track Marshals will record all infringements and report them to the Clerk of the Course.
4. The pit lane exit will be closed to competitors.
5. When the leading competitor approaches the start line at the end of the lap that the neutralisation was decided a "Safety Car" equipped with flashing Yellow Lights on the roof will enter the track with flashing lights switched on.
6. The competitors will end up in single file behind the "Safety Car" without overtaking it.
7. Competitors may now enter the pits but all other rules must be complied with.
8. After stopping at the pits competitors must line up at the pit lane exit and must only rejoin the circuit when instructed to do so by the official with a Green Flag or when the Green Light at that location is switched on. These instructions will be given 10 seconds after the last competitor in line behind the "Safety Car" has passed that point. Competitors must join the back of the line and MUST NOT overtake. The pit lane exit will then be closed and competitors must wait for the next lap.
9. During the last lap of the neutralisation period the "Safety Car" will switch off the Lights on the roof to indicate to the competitors that the "Safety Car" will enter the pit lane at the end of that lap and the race will resume.
10. When the "Safety Car" has left the track overtaking is forbidden up until the start line, where a Green Flag will be waved and the Red Flag with the White Diagonal Cross immediately withdrawn.
11. The pit lane exit will then be permanently re-opened.
12. The race will continue normally.
13. Unless otherwise decided by the Clerk of the Course, each lap completed by the "Safety Car" will be counted as a race lap. A Board displaying the new actual number of laps remaining will be displayed on the start line when the green flag is waved. If the race is eventually stopped under SR 10.1 whilst the "Safety Car" is deployed the result will be according to the position at the last completed lap before the "Safety Car" was introduced.
14. No Protest may be lodged against the decision of the Clerk of the Course regarding the number of laps remaining in order to complete the race.
15. All other rules of the race must be observed.
16. **Exceptions – Clubman Endurance races only**
 1. In Clubman Endurance races, the Clerk of the Course is authorised to deploy the Safety Car at the earliest convenient moment irrespective of the position of each rider in the race.
 2. A Fast Intervention Vehicle may be despatched immediately ahead of the Safety Car.

3. No Protest may be lodged against the effect of any laps lost or gained in respect of Articles 16.1 and 16.2 mentioned above.

SECTION 10 INTERRUPTION OF A RACE

10.1 IF THE CLERK OF THE COURSE DECIDES TO INTERRUPT A RACE DUE TO CLIMATIC CONDITIONS OR SOME OTHER REASON, THEN RED FLAGS WILL BE DISPLAYED AT THE FINISH LINE AND AT ALL FLAG MARSHALS' POSTS.

1. Riders must immediately slow down and return to the pit lane, or as directed by the marshals upon instructions from the Clerk of the Course.
2. If less than three laps have been completed by the leader of the race, then the race will be null and void and a completely new race will be run. If it is found impossible to re-start the race, then it will be declared cancelled and the race will not count for any Championship.
3. If three laps or more have been completed by the leader of the race but less than two-thirds of the current race distance rounded down to the nearest whole number of laps, then the race will be re-started (subject to the provision of Article 10.1.5 below concerning meetings of below National status).
4. If the results calculated show that two-thirds of the original race distance rounded down to the nearest whole number of laps have been completed by the leader of the race, then the race will be deemed to have been completed.
5. Where a race is interrupted at a meeting of below National status the Clerk of the Course is permitted to decide either that a race has been completed or to run a new race over a distance appropriate to the prevailing conditions.

SECTION 11 RE-STARTING A RACE THAT HAS BEEN INTERRUPTED

11.1 IF A RACE HAS TO BE RE-STARTED, THEN IT SHOULD BE DONE AS QUICKLY AS POSSIBLE.

1. The start procedure will be identical to a normal start with sighting lap(s), warm-uplap, etc.
2. In the case of the situation described in Article 10.1.2 above (less than 3 laps completed)
 1. All riders may re-start.
 2. Motorcycles may be repaired or changed. Refuelling is permitted.
 3. The number of laps will be determined by the Clerk of the Course.
 4. The grid positions will be the same as for the original race.
3. In the case of the situation described in Article 10.1.3 above (more than 3 laps and less than two-thirds completed),
 1. Only riders who had completed 75% of the interrupted race may restart.
 2. Motorcycles may be repaired or changed. Refuelling is permitted.
 3. The number of laps will be determined by the Clerk of the Course.
4. Competitors will be restarted from a grid based on the finishing order of the previous part of the race. The finishing order of the previous part of the race will be the order as of the number of laps completed by the race leader, when the red flag was first shown, less onelap.
5. The final race classification will be established according to the position and the number of laps each rider has completed at the time he crossed the finish line at the end of the last part of the race.

SECTION 12 FINISH OF A RACE AND RACE RESULTS

12.1 FINISH OF A RACE

1. When the leading rider has completed the designated number of laps (or the designated time in the case of Endurance) for the race, a Chequered Flag will be displayed at the finishing line.

12.2 THE CHEQUERED FLAG

1. After the Chequered Flag is displayed to the leading Rider no other Rider is permitted to enter the track from the Pit Lane.
2. If a Rider closely precedes the leader during the final lap before the finish line the Official will show to the Riders and to the Leaders simultaneously the Chequered Flag and the Blue Flag. This will indicate to the Leader that he has completed the race and to the Rider closely preceding the Leader that he still has to complete the final lap.
3. In the case of a photo finish between two or more Riders the decision shall be taken in favour of the Rider whose Front Wheel leading edge crossed the finish line first. In the case of Ties, the Riders concerned will be ranked according to the best lap times they achieved in the race.
4. Should the end of the race signal inadvertently or otherwise be displayed before the leading rider completes the scheduled number of laps, or before the scheduled race time has been completed, the race will be deemed to have finished.
If the chequered flag is given to the leader then a result will be drawn accordingly, but if the chequered flag is given to a competitor other than a leader then the result will be taken when the leader last crossed the start/finish line.
Should the end of the race signal be advertently delayed, the race will nevertheless be deemed to finish at the correct moment and competitors be classified accordingly.
5. The Clerk of the Course may require machines to be presented for post Practice or Race verification. Where this is required the Riders must be informed prior to the start of the Practice or Race that they must attend the "Parc Ferme".

12.3 RACE RESULTS

1. When the Race has been completed as described above, the Results will be based on the order in which the Riders crossed the finish line and the number of laps that they have completed.
2. To be counted as a Finisher and be included in the results a Rider must have completed 75% of the actual race distance. He must also have crossed the finish line on the track and not in the Pit Lane within three minutes after the winner and be in contact with his machine.
3. If a race is interrupted either after two thirds distance (as described in Article 10.1.4 above) or after the chequered flag, the Results will be based on the order in which the Riders last crossed the finish line prior to the showing of the red flag. Only riders still racing when the red flag is displayed will be counted as finishers. In these circumstances any Championship points will be awarded in full.
4. A new lap record can only be established during a Race.
5. Both for practice and a race, the lap time is the subtraction of the time between two consecutive crossings of the finish line.

SECTION 13 SAFETY

13.1 MEDICAL SERVICES – MINIMUM REQUIREMENTS FOR ROAD RACE MEETINGS

	PERSONNEL			VEHICLES		
	Doctors MO	Paramedic(s) PM	First Aid personnel	Ambulance(s)	Fast Intervention Vehicle	Special Notes
Road Race	2 MOs	PMs can assist MOs but not replace them	5	2	1	(i)
Road Race Test Day	1 MO	1PM	2	1	1	

The following applies to all events run under this code.

1. **Medical Officer (MO) – DOCTOR** A medical practitioner (Doctor) fully registered with the General Medical Council (GMC), and holding appropriate personal medical malpractice insurance cover (excludes NHS Crown Indemnity).
2. **Paramedic (PM)** A State Registered Paramedic with the HPC (Health Professions Council) Paramedics must have appropriate personal medical malpractice insurance cover.
3. **Ambulance** A vehicle registered as an ambulance with the DVLA (Driver and Vehicle Licensing Agency) and registered with CQC if appropriate. An ambulance must have an appropriately qualified driver to transport a casualty under blue lights. It must be equipped with the FIM minimum equipment regulations for a type C vehicle; that is: Medical: A stretcher (preferably standardised), oxygen supply, apparatus to immobilise limbs and vertebral column. First aid medicaments and materials.
Technical: Radio communication. Visible and audible signals.
Staffing: An ambulance must be staffed by two First Aid Personnel (who can be the two minimum First Aid Personnel).
An ambulance may act as a Medical Centre BUT if so it must be a vehicle in addition to the minimum ambulance requirement.
4. **First Aid Personnel** A person holding a current certificate of First Aid competency. (Where an event is open to the public event organisers should ensure that all First Aid personnel are insured against malpractice for the event concerned).
5. **Fast Intervention Vehicle (FIV)**
 1. A Fast Intervention Vehicle is a compulsory requirement at all Road Race events.
 2. Such a vehicle requires a driver, a Doctor, and appropriate medical equipment. If the driver is not a First Aid Person, then such a Person must be present in the vehicle. This vehicle must be immediately available to proceed to an incident, if called to do so, upon instructions from the Clerk of the Course.
 3. A FIV must not be used in place of an ambulance.
 4. A Fast Intervention Vehicle must be equipped with visible signals (flashing lights).
6. At a meeting of below National status no ambulance or Fast Intervention Vehicle is allowed to be moved onto the course or its immediate verges whilst racing or practice is in progress on any part of the circuit. This means that in the circumstances of an Ambulance or Fast Intervention Vehicle being required on the circuit, the Red Flags must first be displayed and the race or practice brought to an actual and effective halt before the vehicle is deployed.
Note: This restriction is not applicable where the Clerk of the Course has decided to neutralise the race by use of the Safety Car in accordance with the provisions of Chapter 9 of the Road Race Regulations.
7. During Sighting Lap: Stationary or moving Ambulances, Fast Intervention Vehicles, and the like, may be encountered anywhere on the circuit when riders are dispatched from the Assembly Area on their “sighting lap” to the start line prior to the start of a race. This “sighting lap” is not considered to be either Practice or Racing and riders must always be prepared to encounter such vehicles. When such a vehicle or vehicles are on the track the Yellow Flags will be displayed in the appropriate section of the course.
Special Notes
2 MOs must be present at the start of every meeting and be present for the duration of the meeting unless accompanying a patient to hospital. If vehicles or First Aid personnel leave the circuit to convey a patient to hospital then the minimum requirements for the event to continue are 1 MO, 1 FIV, 2 Ambulances and 4 First Aid personnel.
8. **Medical Examination**
At any time during a meeting the Clerk of the Course may require a competitor to undergo a medical examination to determine his fitness to participate. The decision of the Medical Officer is a matter of fact without right of protest.

9. Concussion/suspected concussion

If a competitor is involved in an incident which results in him being diagnosed by the Medical Officer/Paramedic as suffering from concussion/suspected concussion, the rider is not permitted to participate any further in that event.

Organisers are to notify ACU Head Office as soon as possible of any concussion/suspected concussion injuries and then will subsequently:

- a. Place the rider on the ACU Stop List
- b. Inform Organisers of forthcoming events that the Rider has suffered a concussion/suspected concussion injury and is therefore placed on the ACU Stop List
- c. Inform the Rider that he needs to see a Doctor and obtain a letter/doctor's certificate which confirms he is fit to resume competitive racing/participate in a practice/test session.

The recovery time for anyone diagnosed with concussion/suspected concussion is as follows:

- a. Over 20 years: Excluded immediately and suspended for a period of nine days.
- b. 16–19 years: Excluded immediately and suspended for a period of twelve days.
- c. 15 and under: Excluded immediately and suspended for a period of twenty three days.

The rider is not permitted to ride during the obligatory suspended periods outlined above and then only once he is in possession of a doctor's certificate/letter after the suspended period has expired.

A rider may be signed off to ride by the CMO at an event once he has observed the obligatory suspended period outlined above.

If a competitor has been injured on a Saturday and is suffering from concussion/suspected concussion, and the Organiser is aware that the rider was intending to ride or is scheduled to ride somewhere else the next day, the Organiser will inform the Organiser of the event being held the next day so they are aware of the rider's injuries and as such he is prevented from participating in that event.

13.2 TRACK SAFETY PRECAUTIONS

1. The safety precautions of circuits will be as laid down for each Permanent Course Licence or Temporary Course Certificate following an inspection of the course.
2. It should be generally realised that the organisers of speed events have a legal responsibility to the general public and therefore it is the duty of these organisers to ensure that all reasonable precautions are taken to protect the public.
3. Whilst organising Clubs are insured under the Promoters Third Party Policy in respect of their legal liability, it is a condition of the policy that the promoters of an event must comply strictly with the National Sporting Code and any additional requirements as may be specified by the Permanent Course Licence or Temporary Course Certificate. Clubs failing to do so stand in grave danger of any claims being repudiated to the Club by the insurers under the terms of the policy covering legal liability.
4. The safety precautions to be adopted are provided with the Permanent Course Licence or Temporary Course Certificate for the particular course but the following general requirements must be observed.
5. The attention of organisers is drawn to the provision of the NSC which stipulates that no alteration of the requirements contained in the Permanent Course Licence or Temporary Course Certificate shall be made without the prior approval, in writing, of the ACU.
6. It is recognised that circumstances may arise in which it is necessary to make certain alterations to the course on the day of the meeting but any such alterations must be approved by the Stewards of the Meeting and details given in their report to the permit issuing authority.

13.3 FIRE EXTINGUISHERS

Each working vehicle in the Paddock must have a 2kg (minimum) dry powder fire extinguisher

available for immediate use. This extinguisher must show the date of the last annual inspection. Non-compliance with this regulation will incur a penalty imposed by the Clerk of the Course.

13.4 FIRE EXTINGUISHERS AT CIRCUITS

At all race and speed events, there must be a valid certificate, issued annually immediately prior to the start of each season's racing by the manufacturer or his agent, to the effect that all fire extinguishers are in effective working order. This certificate must be available for inspection by the Stewards.

All fire posts must be clearly marked. In addition to the fire equipment at each post there must be:

1. Fire extinguishers in the paddock and assembly area.
2. At least two fire extinguishers in the Technical Control Area.
3. Fire extinguishers in every medical room/centre.
4. During events of National status or below where machines may be refuelled and more than five gallons (22 litres) of fuel is held in any one pit, there shall be a minimum of one fire tender and crew in attendance, appropriately equipped and with immediate access to the pit area. International events must comply with appropriate FIM requirements.

13.5 WARNING AND PROHIBITION SIGNS AT CIRCUITS

For full details regarding Warning Notices and Prohibition Notices please refer to the Safety Precautions section of this Handbook.

1. WARNING NOTICES

The following requirements regarding the display of Warning notices are applicable to all Road Racing events.

1. WARNING NOTICE (A) (29 × 20 inches.) Warning notices as detailed below must be displayed on each side of every entrance to the course, including the entrance to car parks and paddock. These notices must be prominently displayed where they can be easily read by the public before any admission charge is paid, or where no admission charge is made before entry is gained into the circuit.
Where it is not possible to define the limits of the site and to control admission of the public (e.g. M.O.D. Land and heath land) warning notices must be profusely displayed around the course and also in the car parks.
2. WARNING NOTICE ((B) (20 × 15 inches.) Those parts of the course to which the public may be admitted and where it is neither practical nor necessary to erect a barrier, e.g. those parts of the course which are straight and are only used by the public to reach other parts of the course, may be indicated by the erection of the special type of Warning Notice (B). These notices should be displayed at least 30ft. from the course. It is recommended that the limit of these areas should also be defined by a boundary tape.

2. PROHIBITION NOTICES

The following requirements regarding the display of Prohibition notices are applicable to all Road Racing events.

PROHIBITED AREA NOTICE (C) (29 × 20 inches.) Areas where the public are not permitted must be clearly defined by the display of an adequate number of "Prohibited Area" notices (B). Notices should be displayed within the prohibited area, facing the public.

13.6 DECLARATION – ADMISSION TICKETS, ARMBANDS AND PASSES

Subject to the provision of the Sunday Observance Act 1780, no person may be allowed to any part of the circuit without a suitable pass or ticket. All tickets and passes must bear the following wording shown below in full and if the wording appears on the reverse side then the words "For Conditions of Admission See Over" must be clearly printed on the face thereof. Where a ticket is cancelled by being torn in half, the full wording and, where applicable, the "For conditions of admission see over"

must appear on each half. Where a charge is made for admission into special or “reserved” enclosures a ticket bearing the approved declaration must be issued in exchange for payment to enter these enclosures.

Declaration.

WARNING. MOTOR SPORT CAN BE DANGEROUS. Despite the organisers taking all reasonable precautions, unavoidable accidents can happen. Please comply with all instructions of marshals and notices and remain in permitted areas only. **THEY ARE CONCERNED WITH YOUR SAFETY.**

All vehicle passes must bear the same wording and comply with the above requirements.

13.7 DECLARATION ON THE OFFICIAL PROGRAMME

The declaration as outlined above should be printed in full on the outside front cover of all Official Programmes. Where this is not possible it must be printed in full in the programme and the words “For conditions of admission see inside” printed on the outside cover.

13.8 SIGNING ON

All riders, passengers, officials and press must sign a declaration on the relevant signing on form (available from the ACU).

1. Age Limits for Officials.
All event Executive and Administrative Officials shall be 18 years of age or over.
2. Age Limits for Marshals.
 1. All Assistant Officials whose function is to be carried out at the immediate trackside must be at least 16 years of age.
 2. All Assistant Officials who are under 18 years of age must have obtained parental agreement to carry out the duty and the signing-on signature must be countersigned by the person responsible for the official at the event.
3. When using the services of officials under 18 years of age for any duties at any event special attention must be given to any risks which may be associated with the duty, and to the previous experience of the official.

SECTION 14 GENERAL TECHNICAL SPECIFICATIONS

14.1 PROTECTIVE CLOTHING

During practice and racing riders and passengers must wear the following clothing and footwear:

1. A complete all in one leather suit of at least 1.2mm in thickness on all parts of the suit. Suits zipped together at the waist are not permitted. Non-leather material may be used if it meets with the following requirements.
2. The following characteristics of the material must be at least equivalent to 1.5mm of cowhide (not split leather)
Fire retardant quality – Resistance to abrasion – Coefficient of friction against all types of asphalt – perspiration absorbing qualities – Medical test – non toxic and non allergenic – Fabric of a quality that does not melt. It must be non-flammable.
3. The following areas must be padded with at least a double layer of leather or enclosed plastic foam at least 8mm thick: Shoulders, elbows, both sides of the torso and hip joint, the back of the torso, knees.
4. Competitors must wear complete undergarments if they use suits which are not lined. Suitable undergarments may be of the Nomex type, they may also be of silk or simply cotton. Synthetic materials which may melt and which could harm the riders skin in an accident are not allowed, neither for the suit nor for the undergarments.
5. Competitors’ footwear must be of leather or an approved material as per 14.1.2 and a minimum height of 200mm to provide, with the suit, complete protection. No areas of skin to be left exposed between the leg of the suit and the top of the boot.

6. Competitors must wear leather protective gloves. No areas of skin to be left exposed between the wrist of the suit and the wrist of the glove.
7. The use of materials in clothing or personal protection which may generate sparks when in contact with the ground are prohibited.

14.2 HELMETS

Helmets bearing the current ACU gold stamp and in sound condition and properly fitted must be worn by all riders and passengers while practising and racing. Overseas riders may use helmets as approved by their own FMN.

14.3 IDENTIFICATION DISCS

While practising and racing, riders and passengers are required to wear an identification disc around the neck, attached by a material approved by the technical officer. Thin chains should be avoided. The disc must be permanently marked with the wearer's full name and date of birth. Identification discs shall be of a durable material, circular in shape, between 20mm and 25mm in diameter and having rounded edges with no sharp or ragged projections.

14.4 BODY JEWELLERY

It is recommended that any body piercing studs, ring etc. are removed.

14.5 ENGINE AND FRAME NUMBERS

All solo road race machines are required to have engine and frame numbers that have obviously not been tampered with or deleted. For sidecars this applies to engine numbers only. The penalty is disqualification. New unstamped components are permissible.

14.6 FUEL

1. Petrol and Bio-ethanol
 1. Unless otherwise specified in the Supplementary Regulations for any series or championship, leaded petrol mixtures up to 102 RON, will be permitted, provided that the Customs and Excise or Inland Revenue dues have been paid. Power boosters, octane boosters and the like are forbidden.
 2. The use of E85 Bio-ethanol pump fuel is permitted. No concessions to individual Class Technical Regulations are permitted to allow the use of Bio-ethanol fuel. The word Bio Fuel must be clearly displayed on the fuel tank.
 3. Competitors must ensure that a minimum of 2 litres remain in the tank at the end of the race, for the purpose of any fuel testing that may be required.
 4. Any competitor found in contravention of these regulations or who fails to provide a fuel sample will have his Road Race Licence suspended for a minimum period of 6 months of the Road Race Season (March – October) and will be liable for all costs involved in the testing. The competitor will be disqualified from the results and will lose any Championship points awarded for that class.
Note: For information leaded petrol mixtures up to 102 RON are typified by mixtures of 50% Avgas and 50% pump petrol.
2. Methanol
 1. Methanol may be used in any class of Pre-War machine.
 2. An orange day-glow disc (minimum 3 inches diameter) must be affixed on or immediately adjacent to the Racing Number Plate on both sides of any machine using methanol.

14.7 NUMBER PLATES

1. Numbers must be clearly visible to the public and officials. All other number plates or markings

on a motorcycle liable to cause confusion with the number must be removed before the start of a competition.

2. One machine number must be displayed on the front of the motorcycle inclined not more than 30 degrees rearwards from the vertical. Holes can be perforated between the numbers on a front number plate. The actual numbers must not be perforated.
3. Each machine must display two side number plates. The numbers must be clearly visible to the public and marshals on both sides of the machine.
4. If numbers are displayed on separate plates, they must be rectangular shape and made from a rigid and solid material with minimum measurements 285mm by 235mm. The plates should not be curved or bent more than 50mm out of the flat plane.
5. The figures must be clearly legible and like the background must be painted in matt colours as described below to avoid reflection in sunlight.
6. The minimum dimensions of front numbers are:

Background	285mm by 235mm
Height of figure	140mm
Width of figure	80mm
Width of stroke	25mm
Space between two figures	15mm
7. The minimum dimensions of side numbers are:

Background	260mm by 220mm
Height of figure	120mm
Width of figure	70mm
Width of stroke	25mm
Space between 2 figures	15mm
8. A space of at least 5cm must be left free around all number plates in which no advertising may appear.
9. Figures must conform to the Number Plates diagram within this Handbook.
10. The colours for background and figures vary according to the class of motorcycle and type of competition. The following colours shall be used and they must have a matt finish and comply with the RAL colour table:

Black	9005,	Blue	5010,	Yellow	1003,	Orange	2007,
Red	3020,	Green	6002,	White	9010		

The front and side number plates for each class of motorcycles are:

Class	Background	Numbers
F125cc	Red background	White numbers
125cc	Black background	White numbers
250cc	Green background	White numbers
350cc	Blue background	White numbers
500cc	Yellow background	Black numbers
Over 500cc	White background	Black numbers
Formula 400	Blue background	White numbers
Supersport 600	White background	Blue numbers
Formula 600	White background	Blue numbers
Supermono	Black background	Yellow numbers
Stocksport	Red background	White numbers
FII Sidecars	Red background	White numbers
Open Sidecars	White background	Black numbers (incl three wheelers)

14.8 CONTROL OF EXHAUST SOUND LEVEL

1. The Clerk of the Course will disqualify any machine which exceeds the maximum permitted sound level, or which in his opinion is deemed to be excessively noisy. An official sound level test results form will be completed at each meeting and will be submitted by the Clerk of the Course to the Stewards of the meeting.
2. Noise limit in force for all machines is a maximum of 105dB/A. For testing the fixed RPM specified in 6 below will be used.
3. The noise test will be conducted with the microphone placed at 50cm from the exhaust pipe at an angle of 45° measured from the centre-line of the exhaust end and at the height of the exhaust pipe, but at least 20cm above the ground. If this is not possible, the measurement can be taken at 45° upwards.
4. During a noise test, machines not equipped with a gear box neutral must be placed on a stand.
5. The driver shall keep his engine running out of gear and shall increase the engine speed until it reaches the specified Revolutions Per Minute (RPM). Measurements must be taken when the specified RPM is reached.
6. Due to the similarity of the piston stroke in different engine configurations within the capacity classes, the noise test will be conducted at a fixed RPM. For reference only, the mean piston speed at which the noise test is conducted, is calculated at 13m/sec (2-stroke engines) and 11m/sec (4-stroke engines).

SPORT PRODUCTION AND SPORT PRODUCTION BASED ENGINES

	1 Cylinder	2 Cylinder	3 Cylinder	4 Cylinder
250cc (4-stroke)	5,500rpm	8,500rpm		
400cc (4-stroke)	5,000rpm	6,500rpm	7,000rpm	8,000rpm
600cc (4 stroke)	5,000rpm	5,500rpm	6,500rpm	7,000rpm
750cc (4-stroke)	5,000rpm	5,500rpm	6,500rpm	7,000rpm
Over 750cc (4-stroke)	4,500rpm	5,000rpm	5,000rpm	5,500rpm

OTHER 2 STROKE RACING ENGINES

	1 Cylinder	2 Cylinder	3 Cylinder	4 Cylinder
125 (2-stroke)	7,000rpm			
250 (2-stroke)	5,500rpm	7,000rpm		
500 (2-stroke)		5,500rpm	7,000rpm	7,000rpm

7. For Supermono class, Vintage and Classic prior to 1973, the test RPM will continue to depend upon the mean piston speed corresponding to the stroke of the engine, according to the table produced in the ACU Sound Control Regulations.
8. The noise level for engines with more than one cylinder will be measured on each exhaust end.
9. A machine which does not comply with the noise limits may be presented several times at pre- race control.
10. For Supermono class only, when presented for examination, the correct stroke must be stamped in a clearly visible position on the crankcase.
11. For Wankel machines, the noise level will be measured at 6000 RPM.
12. The surrounding noise should not exceed 90 dB/A within a 5 metres radius from the power source during tests.
13. Apparatus for noise control must be to international standard IEC 651, IEC60651, IEC61672 Type 1 or Type 2. The sound level meter must be equipped with a calibrator for control and adjustment of the meter during periods of use.
14. The "slow response" setting must always be used.
15. Due to the influence of temperature on noise tests, all figures are correct at 20°C. For tests taken

at temperatures below 10°C there will be a + 1 dB/A tolerance and for tests below 0°C, a + 2 dB/A tolerance.

16. Noise control after the competition. In a competition which requires a final examination of machines before the results are announced, this examination must include a noise control measurement of at least the first three machines listed in the final classification. At this final test, there will be a 3 dB/A post race tolerance.
17. Guidelines for the use of Sound Level Meters
 1. The Sound Inspector must arrive in sufficient time for discussions with the Clerk of the Course and other Chief Technical Officials in order that a suitable test site and testing policy can be agreed.
 2. Sound level measuring equipment must include a compatible calibrator, which must be used immediately before testing begins and always just prior to a re-test if a disciplinary sanction may be imposed. Two sets of equipment must be available in case of failure of tachometer, sound level meter or calibrator during technical control.
 3. Before testing, the Sound Inspector should if possible liaise with another official who has noise test equipment including calibrators, in order to agree the accuracy of the official sound level meter.
 4. In other than moderate wind, machines should face forward in the wind direction. (Mechanical noise will blow forward, away from microphone).
 5. 'Slow' meter response must be used.
 6. 'A'weighted setting on sound level meter.
 7. Always round down meter reading, that is: 103.9 dB/A = 103 dB/A.
 8. Type 1 meter: deduct 1 dB/A
Type 2 meter: deduct 2 dB/A
 9. Below 10° Celsius: deduct 1 dB/A
Below 0° Celsius: deduct 2dB/A

All tolerances are accumulative. Action taken will depend on the sporting discipline concerned, and decisions taken during prior discussions with the Clerk of the Course.

14.9 EXHAUST PIPES

1. The end of the exhaust pipe or pipes must not project beyond any part of the vehicle or its bodywork. Exhaust gases must not be discharged so as to raise dust or foul the tyres or brakes, or inconvenience a following rider. The end of the exhaust pipe for a minimum distance of 30mm must be horizontal and parallel (within a + or -10 degree tolerance) to the fore and aft centre line of the machine. It must not extend beyond a line drawn at a vertical tangent to the rear edge of the motorcycle rear tyre.
2. For sidecars the exhaust pipes must not extend beyond the limits of the sidecar on the sidecar side and must not extend more than 330mm from the centre of the machine on the opposite side unless contained within the streamlining.

14.10 SUPERCHARGERS/TURBOCHARGERS

1. The use of superchargers/turbochargers is prohibited unless specifically allowed in the regulations for a specific class. An engine, whether two stroke or four stroke, coming within any one of the recognised classes, as determined by the capacity of the working cylinder shall not be considered as supercharged/turbocharged, when in respect of one engine cycle, the total capacity, measured geometrically, of the fuel charging device or devices, including the capacity of the engine working cylinder, if used for inspiring the fuel, does not exceed the maximum capacity of the class in question. The intracylinder injection of fuel shall not be considered as supercharging/turbocharging.

14.11 HANDLEBARS

1. The width of handlebars for motorcycles up to 80cc is not less than 400mm. For all other machines (including sidecars) not less than 450mm. Grips must be attached in such a way that at least the minimum width is reached when measured between the outside ends of the grips. Exposed handlebars must be plugged with a solid material or rubber covered.
2. The minimum angle of rotation of the handlebar on each side of the centre line or mid-position must be 15 degrees for solo motorcycles and sidecars. Whatever the position of the handlebars the front wheel must never touch the streamlining, if any. Stops must be fitted to ensure a minimum clearance of 30mm between handlebar with levers and the tank when on full lock to prevent trapping the rider's fingers (see diagram 3, at the end of Road Race Section).
3. Handlebar clamps must be carefully radiused and engineered so as to avoid fracture points in the bar.

14.12 CLUTCH AND BRAKE LEVERS

1. All handlebar levers (clutch, brake, etc.) must be, in principle, ball ended or be rounded (minimum thickness of this flattened part 14mm). These ends must be permanently fixed and form an integral part of the lever.
2. The maximum length of control levers measured from the pivot-point to the extremity of the ball must not exceed 200mm. Each control lever (hand and footlevers) must be mounted on an independent pivot. The brake lever if pivoted on the footrest axis must work under all circumstances, such as the footrest being bent or deformed.
3. For all types of motorcycles, throttle controls must be self-closing when not held by the hand.
4. Brake Lever Guards must be fitted. They must be robust, suitable for purpose and properly fitted. Classic or Vintage machines racing exclusively in their own race or event are exempt.

14.13 MUDGUARDS

Mudguards are not compulsory. If fitted, the following rules will apply:

1. They must project laterally beyond the tyre on each side. The rear mudguard must cover at least 120 degrees of the circumference of the rear wheel, and the angle contained by a line drawn from the rear end of the rear mudguard to the centre of the rear road wheel and a line drawn horizontally through the centre of the road wheel must not exceed 20 degrees.
2. The front mudguard must cover not less than 100 degrees of the circumference of the front road wheel. The angle contained by a line drawn from the rear end of the front mudguard to the centre of the front road wheel and a line drawn horizontally through the centre of that road wheel must not exceed 20 degrees.
3. Similarly, the angle contained by a line drawn from the front end of the front mudguard to the centre of the front road wheel and a line drawn horizontally through the centre of that road wheel must not be less than 45 degrees nor more than 60 degrees.

14.14 OPEN TRANSMISSION GUARDS

1. For all motorcycles, if the primary transmission is exposed, it must be fitted with a guard as a safety measure. The guard must be conceived in such a manner that under no circumstances can a rider or the passenger come into accidental contact with the transmission parts. It must be designed to protect the rider from injuring his fingers.
2. For Sidecars, a guard is required if secondary transmission is not shielded by the bodywork.
3. A (chain) guard must be fitted in such a way as to prevent trapping between the lower chain run and the final driven sprocket to rear wheel.

14.15 FOOTRESTS

1. The footrests for the rider must be placed not higher than 100mm above a line passing through

the centre of the wheels with a machine loaded and in front of a vertical line passing through the centre of the rear wheel.

2. They must be positioned to give easy access to any control pedals.
3. The ends of the footrests must be rounded with a solid spherical radius of not less than 8mm. Footrests may be of a folding type but in this case must be fitted with a device which automatically allows them to return to the normal position, the integral protection is to be provided at the end of the footrest which must have at least 8mm solid spherical radius.

14.16 OIL SUPPLY PIPES

Oil lines containing positive pressure must, if replaced, be of steel re-inforced construction with swaged or threaded connectors. All drain plugs must be tight and drilled and wired into position. All oil filters must be securely fastened.

14.17 OIL CATCH TANKS & BREATHER SYSTEMS

Where an oil breather pipe is fitted the outlet must discharge into a catch tank located in an easily accessible position and which must be emptied before the start of the race. The minimum size of a catch tank shall be 250cc for gearbox breather pipes and 500cc for engine breather pipes.

14.18 PETROL AND OIL FILLER CAPS

Petrol and oil filler caps when closed must be leak proof. They must be securely locked to prevent accidental opening.

14.19 PETROL TANK BREATHERS

Where petrol tank breather pipes are fitted, non-return valves must be fitted to those pipes.

14.20 CONSTRUCTION

The use of titanium in the construction of the frame, the front forks, the handlebars, the swinging arm spindles and the wheel spindles is forbidden. For wheel spindles, the use of light alloy is also forbidden. The use of titanium alloy nuts and bolts is allowed.

14.21 ADDITIVES TO WATER IN RADIATORS

The only liquid engine coolant permitted, other than lubricating oil, is water.

14.22 BRAKES

For machines fitted with two front disc brakes, a split of the front brake lines for both front brake calipers must be made at or above the lower fork yoke.

14.23 TRANSPONDERS

1. An AMB TranX 260 or a MYLAPS X2 Transponder Bike or compatible transponder must be used.
2. Ensure that the transponder holder is fitted securely, preferably using bolts and Nylock nuts. (If tie-wraps are used at least two sufficiently strong tie-wraps are needed to secure the holder).
3. The transponder must be mounted vertically and not horizontally.
4. The securing pin must be at the top.
5. Fit the transponder holder in a safe and secure position.
6. Mount the transponder so that it is preferably no more than 2ft (60cm) from the ground.
7. Mount the transponder so that it is away from heat generating bodies such as the exhaust.
8. Mount the transponder so that it has a clear view of the ground as possible. Note – the transponder signal will not pass through metal or carbon fibre based plastics.
9. Push the 'R' clip right through as far as possible in order to prevent it being accidentally pushed out.

10. The transponder must be fitted whenever your machine is taken into the assembly area and whenever it is on the course, including timed and untimed practice sessions.
11. Disregarding any of the above guidelines may result in your time(s) not being recorded.
12. No time will be recorded at all if the transponder is not fitted or has not been charged.
13. If attached to the fork leg the transponder must not interfere with the steering lock.
14. The transponder must not be fitted between the top and bottom yokes on the fork legs

Preferred mounting positions:

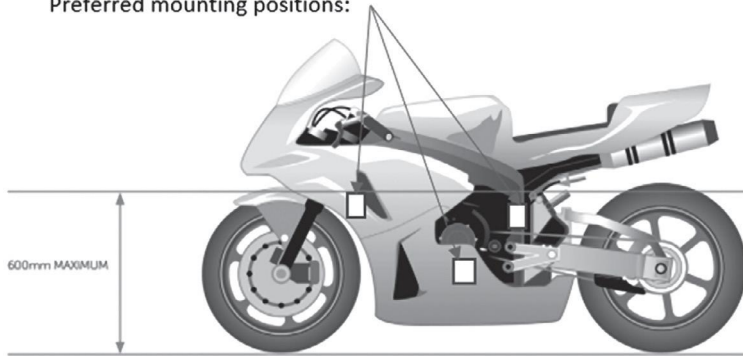

14.24 TECHNICAL CONTROL

1. The Technical Officer shall check both the machine and the rider for compliance with the technical specifications. The rider must wear his clothing to Technical Control to demonstrate good fit etc.
2. The fairing of sidocar machines should be removed and replaced by the competitor during inspection by technical control with particular attention being paid to securing the fairing to the chassis.
3. Crashed machines must be returned to the technical control area for examination. In such circumstances it is the responsibility of the competitor to ensure his machine and clothing has been rechecked and approved before further use in the event.
4. It is the responsibility of the rider to ensure that a machine used in competition is mechanically and structurally in a safe condition.

14.25 TECHNICAL PROTEST

1. In the event of a protest against machine specification where an engine has to be stripped an additional fee of £500 for four stroke and £250 for two stroke machines MUST be submitted with the protest and protest fee. In the event of the protest being upheld the additional fee will be returned. If the protest is not upheld the additional fee will be awarded to the other party and will be the only costs payable.
2. In the event of a protest against fuel specification an additional fee of £1000 must be submitted with the protest and protest fee. In the event of the protest being upheld the additional fee will be returned and the cost of the fuel test charged to the other party. (See also ACU Fuel regulations as detailed within this Handbook).

SECTION 15 SOLO SPECIFICATIONS

These specifications are in addition to and not in place of the General Technical Regulations above. Solo motorcycles must comply with the following requirements.

15.1 SIZE OF WHEEL RIMS AND TYRES

- For solo motorcycles, the wheel rims must be at least 400mm (16") in diameter.
- Any modification to the rim or spokes of an integral wheel (cast, moulded, riveted) as supplied by the manufacturer or of a traditional detached rim other than for spokes, valves or security bolts is prohibited except for tyre retention screws sometimes used to prevent tyre movement relative to the rim. If rim is modified for these purposes bolts, screws etc. must be fitted.
- Tyres must have the following dimensions and will be measured mounted on the rim at a pressure of 1kg/cm² (14lb/sq. in) measurements taken at a tyre section located at 90 degrees from the ground.

Classes	FRONT WHEELS			REAR WHEELS		
	Minimum Rim Width Marking mm	Minimum Inside Width mm	Tyre	Minimum Rim Width Marking mm	Minimum Inside Width mm	Tyre
51cc to 125cc	1.50/WM O	38	50	1.5/WMO	38	50
126cc to 250cc	1.50/WM O	38	63	1.50/WM1	40.5	70
251cc to 350cc	1.60/WM1	40.5	70	1.85/WM1	47	83
351cc to 500cc	1.85/WM1	47	75	2.15/WM2	55	100
501cc to 1300cc	2.15/WM2	55	83	2.15WM3	55	110

15.2 TYPE OF TYRES INCLUDING THE USE OF SLICK TYRES IN CLUB MEETINGS

- For all National meetings the use of slick tyres is permitted. For all other meetings types of tyres must be specified in the Supplementary Regulations. Prior Road Race Committee approval is required for Clubs wishing to permit the use of slick tyres or hand cut slick tyres at meetings below National status.
- Unless stated otherwise in the Supplementary Regulations the use of slick tyres are not permitted at meetings of below National status.

15.3 TREADED TYRES

The minimum tread depth must be 1.6mm unless otherwise stated in Championship Conditions.

15.4 TUBELESS TYRES

If a tyre is to be run tubeless it is recommended that the internal rim dimensions are approved by the manufacturer of the tyres being used. Tyre/rim relationship for tubeless tyre application is very critical.

15.5 SLICK TYRES

The surface of a slick tyre must contain three or more hollows across the width of the tyre at 120 degree intervals or less around its circumference, indicating the limit of wear on the centre and shoulder areas of the tyre. When two or more of these indicator hollows become worn on different parts of the periphery, the tyre must not be used.

15.6 STREAMLINING

The streamlining of solo Road Racing machines must correspond to the following specifications (see also diagram 1 at the end of the Road Race Section).

- The front wheel, with the exception of the tyre, must be clearly visible from each side.

2. No part of the streamlining must be in front of a vertical line drawn 150mm in front of the front wheel axle. Normal mudguards shall not be considered as streamlining.
3. No part of the streamlining must be to the rear of a vertical line drawn through the rear wheel axle and the rim of the rear wheel must be clearly visible over the 180 degrees of its circumference to the rear of this line. No part of the motorcycle shall project to the rear of a vertical line drawn through the exterior edge of the rear wheel.
4. Air foils or spoilers may only be fitted on solo machines when they are an integral part of the fairing or seat. They must not exceed the width of the fairing nor the height of the handlebar. Sharp edges must be rounded off with a minimum radius of 8mm.
5. Any part of the streamlining which faces rearwards, must be finished with rounded edges of 3.5mm min. radius.
6. The rider, in the normal riding position, must be completely visible with the exception of his forearms from either side, from the rear and from above. The minimum space between the face of the rider, or his helmet and the streamlining (including the windscreen) must be 100mm. It is forbidden to use transparent materials to evade these rules.
7. The maximum height of the back of the rider's seat is 150mm. This will be measured from the lowest point of the rigid base of the seat to the uppermost part of the fairing behind the driver.
8. Whatever the position of the handlebars there must be a space of at least 20mm between the streamlining and the ends of the handlebars or other steering systems, including any attachments thereto.
9. The front inclination where the number plate is fixed must not exceed an angle of 30 degrees to the rear of the vertical.
10. The ground clearance of a solo vehicle when unloaded must not be less than 100mm.
11. The width of the seat or anything to its rear shall not be more than 450mm.
12. The fuel cap must be fitted in such a way that it does not protrude from the fairing and cannot be torn off in a crash.
13. It is forbidden to add anything to the original streamlining of Production Racing motorcycles if fitted.
14. Streamlining for both solo and sidecar motorcycles used for World Record Attempts is unrestricted.

15.7 INCLINATION

It must be possible for a motorcycle (other than Vintage machines or Scooters) not being loaded, to be inclined to an angle of 50 degrees from the vertical, without any part of it other than the tyre coming in contact with the ground.

15.8 BRAKES

Motorcycles must be equipped with one efficient brake operating on each wheel and operated independently and concentrically with the wheel.

15.9 OIL CONTAINMENT

The lower fairing where fitted on all four stroke motorcycles must be constructed to hold at least half of the total oil and coolant capacity of the engine in the event of an engine failure. The lower edge of openings in the fairing must be positioned at least 50mm above the bottom of the fairing. (Minimum modifications to the profile of the lower fairing only to fulfil this rule). (Please see diagram). Four stroke motorcycles without a lower fairing must fit a sub-reservoir below the crankcase to hold at least half of the total oil and coolant capacity of the engine in the event of an engine failure.

NOTE: Vintage and Classic machines (prior to 1973) racing exclusively in their own race or event are exempt, at the discretion of the organiser.

15.10 RED REAR WARNING LIGHTS

All motorcycles must have a functioning red light mounted at the rear of the machine to be used in rain or low visibility conditions as instructed by Race Control. The team/rider must ensure that the light is switched on whenever a rain tyre is fitted on the motorcycle and/or when any practice or race is declared "wet" by Race Control.

Lights must comply with the following:

- a) Lighting direction must be parallel to the machine centre line (motorcycle running direction), and clearly visible from the rear at least 15 degrees to both left and right sides of the machine centre line.
- b) Mounted on the seat/rear bodywork approximately on the machine centre line, in a position approved by the Chief Technical Officer. In case of dispute over the mounting position or visibility, the decision of the Chief Technical Officer will be final.
- c) Power output/luminosity equivalent to approximately: 10–15W (incandescent) 0.6–1.8W (LED).
- d) The switch must be accessible.
- e) Rain light power supply may be separated from the motorcycle main wiring and battery. Classic or Vintage machines racing exclusively in their own race or event are exempt.

SECTION 16 SOLO ELIGIBILITY SPECIFICATIONS

16.1 ACU PRODUCTION CLASSES

1. These specifications are in addition to and not in place of the Technical Regulations. Solo motorcycles must comply with the following requirements. Machines must be complete, fully equipped motorcycles of a Model/Marque to UK specifications, as originally assembled at the factory of a recognised manufacturer, for road use in a minimum quantity of 100.

The only permitted alterations are detailed below.

2. Handlebars – any shape of handlebar is permitted provided that it is fitted in the original mounting position only.
3. Footrests and foot controls – proprietary rearsets are acceptable.
4. Gearing – the sprockets may be changed. The final drive chain specification must remain standard in respect of width and pitch.
5. Friction linings, disc pads and brake hoses – may be changed.
6. Compression springs and damping – may be changed, but the original mountings must be used.
7. Exhaust systems – no modification is permitted.
8. Rebores – to allow for wear, rebores will be permitted, but only to the maximum of the manufacturer's recommended re bore sizes.
9. Air filter elements – may be removed. Air box assemblies must not be modified.
10. The addition of the following is permitted – security bolts and screws, steering dampers, fork braces, engine protection bars.
11. Carburettors – no modification other than a change of jet size is permitted.
12. Compression ratio – cylinder head joint faces may be machined – the external appearance of the engine must remain unaltered. Where originally specified, a solid head gasket must be retained.
13. Side stand mounting lugs – may be removed.
14. Throttle controls – must be self-closing as Article 14.12.3. The following alterations **must** be made:
15. Licence holders, club badges (except transfers), centre and prop stands, luggage carriers, mirrors and rear registration plate (but NOT tail light) must be removed. Indicators may be retained at the discretion of the rider but, if retained, the glasses must be taped.
16. Where breather pipes are fitted they must discharge via existing outlets into a catch tank as per Article 14.18.

17. Head lamp and rear light glasses must be adequately taped to prevent splintering.
18. All electrical equipment fitted must be in working order except the stop lamp which MUST be disconnected.
19. No addition or alteration by machining, welding, brazing, silver soldering or bonding may be carried out externally to any part of the machine.

16.2 FORMULA SPECIFICATIONS

These specifications are in addition to and not in place of the Technical Regulations. Solo motorcycles must comply with the following requirements.

1. Classes

- 125 – Production based machines up to 125cc two stroke (includes the 72cc and 80cc Jawa and Metrakit type machines)
 - 250 – Production based machines 250cc four stroke.
 - 400 – Production based machines 250cc two stroke, 400cc four stroke.
 - 600 – Production based machines 600cc four stroke four cylinder and 675cc four stroke three cylinder.
2. Rebore up to the manufacturer's maximum recommended rebore size are permitted.
 3. Any moulded treaded tyre is permitted.
 4. Standard carburettors or fuel injection as homologated to be used.

16.3 ACU SUPERSPORT REGULATIONS

To comply with 2016 FIM Regulations and/or MCRCB Regulations with the exception of noise levels.

16.4 ACU/FIM SPECIFICATIONS FOR SUPERBIKE

To comply with 2016 FIM Regulations and/or MCRCB Regulations with the exception of noise levels.

16.5 ACU STOCKSPORT/SUPERSTOCK REGULATIONS

To comply with 2016 FIM Regulations and/or MCRCB Regulations with the exception of noise levels.

16.6 ACU SUPERSTOCK 600

To comply with 2016 FIM Europe Regulations with the exception of noise levels.

SECTION 17 SIDECAR SPECIFICATIONS

These specifications are in addition to and not in place of the Technical Regulations. Sidecars must comply with the following requirements. All Fuel used must comply with the ACU Standing regulations.

17.1 GROUPS B1 AND B2 – GENERAL

1. The three road wheels may be disposed so as to give two or three tracks.
2. If three tracks are made then the centres of the tracks of the motorcycle shall not be more than 75mm apart.
3. The sidecar may be placed either side of the motorcycle. Hinged sidecars and steerable sidecar wheels are forbidden. Remote steering linkages and the use of articulated joints in the steering mechanism are not allowed. By definition an articulated joint is one allowing movement in more than one plane.
4. The distance between the fore and aft centre lines of the tracks made by the motorcycle rear and sidecar wheels must be not less than 800mm and not more than 1150mm. Maximum dimension for a B2 overall width 1700mm (including exhaust systems). Maximum overall height of 800mm at front. Maximum overall length 3300mm. Maximum wheelbase 2300mm.
5. The minimum dimensions of the sidecar body shall be length 800mm, width 300mm (both measured 15cm above the platform). Height of the passenger's protective screen 300mm. Any

bodywork or fairing must not protrude more than 400mm in front of the most forward part of the front tyre or rearward more than 400mm from the most rear part of the rear tyre.

6. The engine must be positioned in front of the rear wheel in such a way that the centre line of the engine – determined by half its overall width, shall not extend more than 160mm beyond the centre line of the rear wheel track of the motorcycle. By definition the centre line of the engine is the position midway between the centre lines of outermost cylinders for transverse engines or the crankshaft for in-line engines.
7. Any form of electronic traction control remains forbidden, this means that any traction control system whether it is a part or a full system that is fitted as standard on an homologated machine/engine CANNOT be used. Wheel speed sensors are not permitted.
8. The ground clearance measured over the entire length and width of the vehicle race ready, fully loaded with rider, passenger and fuel must be not less than 65mm with the handlebar in a straight position. No device is permitted to reduce the 65mm ground clearance during the course of the event. The under surface of the platform must, in principle, be flat.
9. The suspension of the front wheel must be designed so that under suspension action and in a straight ahead position, it shall only move vertically and in a single plane relative to the motorcycle – the plane must be in the driving direction. This must occur without changes to the camber or the tracking. The vertical travel of the front and rear wheel spindles under suspension action must be at least 20mm.
10. The motorcycle must be steered by a non adjustable handlebar which is directly fixed to the steering unit of the motorcycle. The handlebar must not be lower than the spindle of the front wheel. The steering unit must operate through the front wheel.
11. The provision of coachwork or streamlining is optional, but the vehicle must have accommodation for a passenger and the coachwork or streamlining shall not impede complete freedom of movement by the rider or passenger at all times. Neither driver or passenger may be attached to the machine (exception the driver must be attached by the cut out lanyard). The streamlining must be easily detachable for inspection by technical control.
12. RIDER. The rider in the normal riding position must be completely visible, with the exception of the arms, legs, and feet from above.
PASSENGER. A passenger must be carried and must always be protected from the road wheels and both primary and final drives either by mudguard or some other means. The passenger must be able to lean out to either side of the sidecar, for this purpose the vehicle must be fitted with suitable hand-holds for the passenger to hold onto when leaning out. The handholds must be of the 'CLOSED LOOP' type, a single projection hand-hold is not permitted.
13. There shall be a clearance of at least 20mm between the streamlining and the extremities of the handlebar, including any attachments thereto whatever the position of the handlebar.
14. The battery must be covered in such a way that neither the rider or the passenger can come in to contact with the battery or its contents.
15. A solid and effective protection between the rider and the engine must prevent direct contact between his body or clothes and/or escaping flames or leaking fuel and oil.
16. Throttle Controls and Cut Out Device
 1. Throttle controls must be self-closing when not held by the hand.
 2. An ignition cut-out must be fitted to operate when the driver leaves the machine. This ignition cut-out system must interrupt the primary circuit and must be wired for both the supply and return of the current.
 3. The ignition cut-out must be placed as near to the centre of the handlebar as possible and must be operated by a non-elastic string of adequate length and thickness and strapped to the driver's body. A spiral cable (similar to that of a telephone wire) of maximum 1m extended length is permitted.
17. Any electric fuel feed pump must be wired in such a way as to cut out if the engine cut out device is operated.

18. The fuel tank must be sufficiently independently protected from the ground. A non-return valve must be fitted to the petrol tank breather pipe, this pipe must discharge into a suitable catch tank, minimum capacity 500ml. The fuel filler cap must be fitted in such a way that it does not protrude from the fairing and cannot be torn off in the event of an accident.
19. All handlebar levers (clutch, brake etc.) must be ball ended. The ball diameter must be at least 19mm permanently fixed and forming an integral part of the lever. The maximum length of control levers measured from the pivot point to the extremity of the ball must not exceed 200mm. Each control lever (hand and foot) must be mounted on an independent pivot. The handlebar grips must not be longer than 150mm and must be attached to the ends of the handlebar.
20. The rear driving wheel must be covered down to the level of the sidecar platform on the nearest side to the sidecar wheel, and to the top of the rear wheel rim flange on the outside. The rear facing section of the rear seat must cover the rear driving wheel down to the level of the rear wheel spindle.
21. The exhaust system must fulfil all the requirements concerning noise control. Exhaust fumes must be discharged towards the rear but not in a manner as to raise dust, foul the tyres or brakes or inconvenience a passenger or any other rider. The furthest extremity of the exhaust pipe must not exceed a vertical line drawn at a tangent to the rear edge of the sidecar platform. On the side opposite a sidecar the exhaust pipes must not extend beyond the streamlining. On the other side the exhaust pipes must not extend beyond the width of the sidecar. Exhaust pipes must be fitted/positioned so that it is impossible for them to become entangled with another machine.
22. An airbox must be used with all four-stroke engines. The airbox intake size is not restricted. (Except four-stroke engines in Formula II Class)
 1. The airbox must completely close around the induction bell-mouths.
 2. The carburettors or throttle-bodies may be entirely within the airbox.
 3. The engine must have a closed breather system.
 4. The engine breather must be connected and discharge in the airbox only. (by a sealed catch tank if required)
 5. The airbox must cover and collect fluids discharged from the bell-mouths.
 6. The airbox must be constructed in such a way as to prevent any oil discharged in the airbox from spilling on the track.
 7. This oil containment must hold a minimum of 1000cc of oil.
 8. The airbox must be sealed to prevent spillage of oil or fuel.

17.2 GROUP B3 (CYCLECARS) – GENERAL

1. The three road wheels, which may be disposed to give either two or three tracks shall be each of at least 400mm in diameter measured over the outside of the tyre, or in the case of a scooter with sidecar attached, as provided in the ACU Scooter Standing Regulations.
2. One of the wheels may be replaced by two wheels provided the distance between the two vertical centre lines of these two wheels does not exceed 200mm.
3. The wheel track, or lateral distance between tracks shall be at least 800mm.
4. The position of the engine is optional and the engine may drive one or more road wheels.
5. The provision of coachwork or streamlining is optional, but the vehicle must have accommodation for one or more passengers.
6. The passenger must always be completely protected from the road wheels and drive, either by mud-guarding or some other means.
7. A passenger must be carried in addition to the rider unless the Supplementary Regulations have authorised the substitution of ballast. In such case, the ballast must consist of a single object placed on, and fixed to the passenger's seat, and of a weight of at least 132lb (60kg).
8. Throttle controls must be self-closing.

17.3 GROUP B1, B2 AND B3 TECHNICAL SPECIFICATIONS

1. Streamlining

1. The streamlining on three-wheelers must be designed and fitted to allow complete liberty of movement to the rider, both when riding and when getting on or off the vehicle, without the streamlining or any part of it having to be displaced.
2. For B1 and B2 sidecars neither the rider nor the passenger must be covered from above nor may they be attached in any way. Furthermore, the passenger must be able to lean out on either side. Spoilers and other aerodynamic devices must not surpass the streamlining. The streamlining must not have any sharp edges.
3. The extreme forward part of the streamlining must not project forward in plan beyond the most forward part of the front tyre by more than 400mm.
4. There shall be a clearance of at least 20mm between the streamlining and the extremities of the handlebar (or other form of steering lever), including any attachment thereto whatever the position of the handlebar.
5. Streamlining must be held to the machine by means of chassis extensions etc.
6. There must be no possibility of the streamlining coming into contact with the road surface, impeding the front wheel or steering of the machine in the event of the failure of any individual fairing mounting point.

2. Brakes

Motorcycles in Group B1 and B3 must be equipped with at least two brakes, operating independently on at least two of the road wheels, each giving complete control from the riding position. If hydraulic system is used it must comply with Group B2 rules (below). All vehicles in group B2 must have the following braking system. All three wheels must be braked.

1. The brake system must consist of one main system with at least two circuits operating separately, one of the circuits must operate on at least two of the three wheels.
2. If one circuit fails the other must work efficiently.
3. An emergency system operated by a handlebar lever or a foot lever with a simple circuit operating on either the front or rear wheel of the motorcycle.
4. A sidecar brake is mandatory.
5. Dispensation has been given to any long type sidecars with respect to the auxiliary handlebar operated brake.
6. Only ferrous brake discs are permitted. (For Classic and Vintage rules contact the relevant bodies).

3. Wheels and Tyres

For sidecars and three-wheelers (Group B1, B2 and B3), the wheel rims shall be at least 254mm in diameter and 64mm in width. All wheels must be of metal construction, any modification to the rim or the spokes of the original cast or composite wheel as supplied by the manufacturer is prohibited.

For all meetings the use of slick tyres is permitted. The diameter of the tyre must be at least 400mm and the width 100mm, maximum front tyre width 220mm.

1. Tubeless Tyres. If a tyre is to be run tubeless it is recommended that the internal rim dimensions are approved by the manufacturer of the tyres being used. Tyre/rim relationship for tubeless application is very critical.
2. Slick Tyres. The surface of a slick tyre must contain three or more hollows across the width of the tyre around its circumference at 180 degree intervals or less, indicating the limit of wear on the centre and shoulder areas of the tyre. When at least two of these indicator hollows across the width of the tyre become worn on different parts of the periphery, the tyre must no longer be used.

4. Red Warning Lights

Sidecars must be equipped for the duration of the event with a functional rear facing red anti-

fog lamp, measuring a minimum of 30 sq cm, and producing a minimum 1500 MCD light. The light must be installed at least 100mm off the ground, located in the area between the back wheel and the sidecar platform. The light must be mounted on a part of the suspended body (not on any unsuspended parts) and ensure no obstruction from the fairing and/or the passenger.

Red lights must be switched on when a "Wet Race" is declared.

5. Air Intakes

Cooling air intakes must be so constructed that there is NO forward projection/protrusion to catch or foul in the event of accident.

6. Oil and Coolant Containment

1. In the area directly below the engine, the oil containment tray must be constructed to hold, in case of an engine breakdown at least half of the total oil and engine coolant capacity used in the engine (minimum 5 litres). The surrounding edges of the tray must be at least 50mm above the bottom of the tray.
2. The front edge of the oil bay reservoir wall must be extended upwards to just below (within 20mm) the exhaust ports of the engine.
3. Holes for the engine mounts (hangers) must be sealed.
4. From a vertical view, the engine must be located completely inside the oil bay platform.
5. The rear wheel must be protected from any possible oil spray. To make this protection, the engine and rear wheel compartment must be separated. This separation must be created by installing a solid divider (wall) running from the top of the inside of the bodywork to the bottom of the oil tray. This divider (wall) must overlap the rear edge of the oil tray down to the bottom.
6. All machines must use this tray.
7. Oil cooler must not be mounted on or above the body of the sidecar. The location of the oil tank and oil cooler should be placed where it is least likely to be damaged in an accident.
8. Oil lines containing positive pressure, if replaced must be of metal reinforced construction with swaged or threaded connectors. Manufactured solid construction oil lines, where practical, must be replaced also. All sidecars shall attach oil absorbent materials of no less a quality than 3M Product number T156 or CEP Sorbents product number CEP-EP100.

This material shall be securely fixed to the following areas of the sidecar:

1. The entire oil tray, both the bottom and inside wall of the same. The volume of material used in this area according to manufacturer's specifications, shall not be less than 3 litres of oil.
 2. Any bodywork directly covering the engine. In the event that oil is absorbed by the material, it must be replaced before the next track session.
 3. The material must be attached in such a way that it should be easily replaced, yet not become displaced while on the track, and its effectiveness is not inhibited, i.e. if an adhesive is used it must not clog the material, causing it to lose its absorbent properties. All absorbent material used, shall be non-flammable by design. Vintage and Classic (prior to 1973 construction) machines are exempt from the above requirement 6.8.
 4. Where an oil breather pipe is fitted the outlet must discharge into a catch tank in an easily accessible position which must be emptied before the start of the meeting, minimum capacity 500ml.
- 7. Oil Catch Tanks**
1. Two strokes. Where an oil breather pipe is fitted, the outlet must be discharged into a catch tank located in an easily accessible position and which must be emptied before the start of the race. The minimum size of catch tank shall be 250ml for gearboxes.
 2. Four-stroke. Motorcycles must have a closed breather system. The oil breather line must be connected and discharge in the airbox only. (by a sealed catch tank if required)

SECTION 18 OPEN 600 AND FORMULA II SIDECAR SPECIFICATIONS

Open 600 and Formula II Sidecars must comply with the general Sidecar specification unless changed by the following specifications:

Introduction. The object of this specification is to make use of cheaper, more readily available engine units of theoretically similar power outputs and of widely different configurations and hopefully to provide less expensive racing of a more traditional kind to the benefit of competitors, constructors and spectators. Hub centre steering, remote steering linkages and the use of articulated joints in the steering mechanism are not allowed.

18.1 ENGINE TYPES

The only permitted engines for the Open 600 sidecar class are:

Up to 350cc 2 stroke, twin
cylinder 501–600cc, 4 stroke, 4
cylinder

Production based Rotary engines are not permitted. Over-boring is not permitted.
Induction systems.

For the FII British Sidecar Championships and other events as specified

a. The only permitted engines for this class are:

501–600cc, 4 stroke, 4 cylinder, Production based. 501–600cc, 4 stroke: Any carburettor is permitted.

501–600cc four-stroke Fuel injection engines: Fuel injection systems are permitted using only the throttle-bodies as homologated for the engine concerned.

The injectors must be standard units as on the homologated engine.

Bell mouths, intake tract devices (Velocity stacks, air funnels) may be modified or replaced. Variable length intake devices (Velocity stacks, air funnels) that function while the engine is operating are not allowed, unless such a system is used on homologated machine/engine. Butterfly cannot be changed or modified. Where fitted a secondary butterfly or slide may be locked in the fully open position.

Any fuel pump may be used but fuel pressure must remain as homologated for that engine. Homologated fuel pressure regulators must remain unmodified.

The fuel ignition ECU and Ignition Control Unit may be changed.

b. Cylinder heads to Supersport specification allowed

c. Everything below the head gasket is free.

d. Fuel injection instruments/fuel injectors must remain as homologated.

e. These regulations should remain unchanged for at least 3 years 2017 onwards.

18.2 GENERAL CONSTRUCTION

The Sidecar may be placed either side of the motorcycle. Hinged sidecars and steerable sidecar wheels are forbidden. Neither the rider nor passenger may be attached to the machine. Remote steering linkages and the use of articulated joints in the steering mechanism are not allowed. By definition an articulated joint is one allowing movement in more than one plane.

The three road wheels may be disposed as to give two or three tracks.

If three tracks are made then the centres of the tracks of the motorcycle shall not be more than 75mm apart.

A passenger must be carried and must always be protected from the road wheels and both primary and final drives either by mudguard or some other means.

The main frame (See Figure 1A) must consist of a minimum, of a steering head, a frame to accommodate the engine, and a main spar to the sidecar wheel, which will be made from good quality steel tube.

The tubing used for the construction of the frame may be of a circular or non-circular section. If

circular, the outside diameter shall not exceed 101.6mm. If non-circular, the maximum cross section shall not exceed 101.6mm. measured at right angles to any flat face.

These three components must be permanently fixed by welding or brazing.

The rear swinging arm outer pivot housings (See Figure 1B) may be detachable from the main frame, the pivot housings must be made from either steel or a suitable solid aluminium alloy billet. The finished article if made from aluminium alloy must be hard anodised. The use of castings for the outer pivot housings are forbidden.

The sidecar wheel upright or flange plate (See Figure 1C) at the end of the main sidecar wheel spar may be detachable, the upright flange plate must be made from either steel or a suitable solid

aluminium alloy billet. The finished article if made from aluminium alloy must be hard anodised, any supporting tie rods to the upright or flange plate must be made of steel. The use of castings for the sidecar wheel upright or flange plate are forbidden.

The sidecar wheel stub axle housing (See Figure 1D) may be detachable from the sidecar wheel upright/flange plate, the housing must be made from either steel or a suitable solid aluminium alloy billet. The finished article if made from aluminium alloy must be hard anodised. The use of castings for the sidecar wheel stub axle housing are forbidden.

Reinforcement of the steering head is allowed. The steering head may be fully boxed in to a maximum of 305mm, measured from any point between the top and the bottom of the steering head spindle centre line (See Figure 1 X.X). Should any lightening or inspection holes be added to the "Fully Boxed In" section, they will be deemed as still "Fully Boxed In" and not open.

The front forks should be either a leading/trailing fork, or links with the wheel equally supported on each side. The construction of the front forks and yokes must be made of good quality steel and must be either welded or brazed during construction. The lower loop must be made of good quality steel. Minimum suspension travel to be 20mm.

The rear swinging arm must be made of good quality steel, single sided swinging arms are allowed, and must have minimum of 20mm of travel in a single plane. The rear swinging arm pivot spindle must be 90 degrees to the fore and aft centre line of the rear wheel. The swinging arm must either be welded or brazed during construction, the dimensions for the swinging arm are free. Wishbone type swinging arms fitted to monocoque chassis's are forbidden.

The use of composite construction is forbidden with the exception of the sidecar platform, i.e. aluminium or carbon fibre skinned honeycomb.

The use of titanium in the construction of the frame, front forks, handlebars, swinging arm and wheel spindles is forbidden.

For wheel spindles, the use of light alloys is also forbidden. Under trays must be detachable.

Monocoque construction is forbidden.

18.3 ENGINE POSITION

The engine must be positioned in such a way that the centre line of the engine (by definition a position midway between centre lines of outermost cylinders) shall not exceed 160mm beyond the centre line of the rear wheel of the motorcycle.

The engine must be positioned behind the steering head and in front of the driver.

The drive must be transmitted to the road through the rear wheel of the motorcycle. An engine positioned behind the rider and in front of the rear wheel is forbidden.

18.4 DIMENSIONS

Weight (Minimum) 136.5kg. without fuel. The addition of ballast to reach this weight is forbidden. Width (Overall Maximum) 1575mm.

Wheelbase (Maximum) 1651mm.

Track 800mm minimum, 1105mm maximum. The distance is measured from the centre of the track left by the rear wheel to the centre of the track left by the sidecar wheel.

Height (Overall Maximum) 800mm.

Ground clearance. The ground clearance measured over the entire length and width of the vehicle race ready, fully loaded with rider, passenger and fuel must be not less than 65mm with the handlebars on in a straight position. No device is permitted to reduce the 65mm ground clearance during the course of the event.

Note: The imperial measurements are no longer used so the Metric figures have been rounded up to nearest mm the differences were 0.1mm and 0.2mm.

18.5 STREAMLINING AND BODYWORK

The streamlining must be easily detachable for Technical Inspection. Aerofoils or spoilers are not permitted on streamlining.

The forward extremity of the streamlining shall not be more than 400mm in front of the line taken from a vertical tangent to the front tyre.

The extreme rear edge of the streamlining must not be more than 400mm to the rear of the line taken from a vertical tangent to the rear tyre.

The provision of coachwork or streamlining is optional, but the vehicle must have accommodation for a passenger and the coachwork or streamlining shall not impede complete freedom of movement by the rider or passenger at all times.

Whatever the position of the handlebars, there must be a space of at least 20mm between the streamlining and the ends of the handlebars or any other parts of the steering mechanism or front wheel.

A solid and effective protection must be fitted between the rider and the engine, this protection must prevent direct contact between the rider's body or clothing and escaping flames or leaking fuel or oil. The fairing must be mounted in such a way as to ensure the integrity of the whole installation in the event of failure of any individual mounting.

18.6 PASSENGER PLATFORM

Minimum dimensions 800mm by 300mm measured 150mm above the platform. The orientation is free.

RIDER The rider in the normal riding position must be completely visible, with the exception of the arms, legs, and feet from above.

PASSENGER The passenger must be able to lean out to either side of the sidecar, for this purpose the vehicle must be fitted with suitable hand-holds for the passenger to hold on to when leaning out. The hand-holds must be of the closed loop type, a single projection hand-hold is not permitted.

18.7 AIR INTAKES

Cooling air intakes must be so constructed that there is NO forward projection/protrusion to catch or foul in the event of accident.

18.8 OIL AND COOLANT CONTAINMENT

In the area directly below the engine, the oil containment tray must be constructed to hold, in case of an engine break down, at least half of the total oil and engine coolant capacity used in the engine (minimum 5 litres).

The surrounding edges of the tray must be at least 50mm high measured vertically from the bottom of the tray.

The frontal edge of the oil tray wall must be extended upwards to arrive just below (within 20mm) of the exhaust ports of the engine.

Holes for the engine mounts (hangers) must be sealed.

From a vertical view, the engine must be located completely inside the oil tray platform.

The rear wheel must be protected from any possible oil spray. To make this protection, the engine and rear wheel compartment must be separated. This separation must be created by installing a solid

divider (wall) running from the top of the inside of the bodywork to the bottom of the oil tray and to the full width of the rear tyre. This divider (wall) must overlap the rear edge of the oil tray down to the bottom.

All machines must use this tray.

All sidcars shall attach oil absorbent materials of no less a quality than 3M Product number T156 or CEP Sorbents product number CEP-EP100.

This material shall be securely fixed to the following areas of the sidcar.

The entire oil-tray, both the bottom and the inside walls of the same. The volume of material used in this area, according to the manufacturers specifications, shall absorb not less than 3 litres of oil.

Any bodywork directly covering the engine.

In the event that oil is absorbed by the material, it must be replaced before the next track session. The material must be attached in such a way that it should be easily replaced, yet must not become dislodged whilst on the track, and its effectiveness is not inhibited, i.e. if an adhesive is used it must not clog the material, causing it to lose its absorbent properties.

All absorbent material shall be non-flammable by design.

Oil-lines containing positive pressure, if replaced, must be of metal reinforced construction with swaged or threaded connectors.

Oil coolers must not be mounted on or above the bodywork of the sidcar.

The location of the oil tank and the oil cooler should be placed in a location where it is least likely to be damaged on an accident.

For 2018 onwards all oil lines must be professionally manufactured and certified.

Sump plug, oil filters, Ignition pickup covers and Clutch centre covers should all be lockwired or lockplated.

The gear lever should exit via a rubber boot or flexible seals if the gear lever exits outside the retaining area.

The chain slot must have a flexible seal fitted.

18.9 AIRBOX

An airbox must be used with all four-stroke engines. The airbox intake sizes are restricted as follows:

If 1 intake is used a maximum of 103mm Internal Diameter is permitted.

If 2 intakes are used a maximum of 73mm Internal Diameter per intake is permitted or equivalent area if none circular section(s) are used measured within 50mm of the point of entry into the airbox.

The airbox must completely close around the induction bell-mouths. The carburettors or throttle-bodies may be entirely within the airbox. The engine must have a closed breather system.

The engine breather must be connected and discharge in the airbox only (by a sealed catch tank if required)

The airbox must cover and collect fluids discharged from the bell-mouths.

The airbox must be constructed in such a way as to prevent any oil discharged in the airbox from spilling on the track.

This oil containment must hold a minimum of 1000cc of oil.

The airbox must be sealed to prevent spillage of oil or fuel.

18.10 OIL CATCH TANKS

Four-stroke motorcycles must have a closed breather system. The oil breather line must be connected and discharge into the airbox only. (by a sealed catch tank if required).

18.11 WHEELS

The minimum diameter of an inflated tyre must be 400mm. All wheels must be of metal construction,

any modification to the rim or the spokes of the original cast composite wheel as supplied by the manufacturer is prohibited.

18.12 STEERING

Steering of the front wheel must be accomplished by non-adjustable handlebars securely fixed to the forks or yokes of the motorcycle. They must be secured to steering members turning the front wheel and its supports directly with no intermediate push or pull rods. Handlebars and all steering bearings must be located on the sprung portion of the front suspension.

Any form of remote steering is forbidden.

Handlebar width 450mm minimum.

Steering lock angle each side of straight ahead position to be 20 degrees minimum, measured at the headstock.

Whatever the position of the handlebars the front wheel must never touch the streamlining. Handlebar clamps must be carefully radiused and engineered so as to avoid fracture points in the bar. Any butt welded handle bars must be suitably gusseted.

18.13 THROTTLE CONTROLS

Throttle controls must be self-closing when not held by the hand.

18.14 CONTROL LEVERS

All handlebar levers (clutch, brake etc.) must be ball ended. The ball diameter must be at least 19mm permanently fixed and forming an integral part of the lever.

18.15 BRAKES

All three wheels must be braked. The brake system must consist of:

One main system with at least two circuits operating separately, one of the circuits must operate on at least two of the three wheels.

If one circuit fails the other must work efficiently.

An emergency system operated by a simple circuit operating on either the front or rear wheel of the motorcycle is compulsory.

Only ferrous discs allowed.

18.16 TYRES

For all meetings the use of slick tyres is permitted. The wheel rim shall be at least 254mm in diameter and 64mm in width. The diameter of the tyre must be at least 400mm and the width 100mm, maximum front tyre width 220mm.

The surface of a slick tyre must contain two or more hollows at 180 degree intervals or less, indicating the limit of wear on the centre and shoulder areas of the tyre. When at least two of these indicator hollows become worn on different parts of the periphery, the tyre must no longer be used.

18.17 MUDGUARDS AND WHEEL PROTECTION

The rear driving wheel must be covered down to the level of the sidecar platform on the sidecar platform side of the wheel and to the centre of the driving wheel on the outermost side of the wheel. The rear facing section of the rear seat must cover the rear driving wheel down to the level of the rear wheel rim.

The sidecar wheel must be enclosed from the sidecar platform and level with the sidecar platform on the outside and around the periphery. Provision for the checking of the sidecar wheel tyre pressure is allowed.

18.18 EXHAUST PIPES

The exhaust system must fulfil all the requirements concerning noise control. Exhaust fumes must be

discharged in a manner so as to not raise dust, foul the tyres or brakes or inconvenience a passenger or any other driver. The furthest extremity of the exhaust pipe must not exceed a vertical line drawn at a tangent to the rear edge of the sidecar platform. On the side opposite a sidecar the exhaust pipes must not extend beyond the streamlining. On the other side the exhaust pipes must not extend beyond the width of the sidecar. Exhaust pipes must be fitted/positioned so that it is impossible for them to become entangled with another machine.

18.19 FUEL TANK

Fuel tanks must be sufficiently independently protected from the ground. A non-return valve must be fitted to the petrol tank breather pipe, this pipe must discharge into a suitable catch tank, minimum capacity 500ml. The fuel filler cap must be fitted in such a way that it does not protrude from the fairing and cannot be torn off in an accident.

18.20 BATTERY

The battery must be covered in such a way that neither the driver nor the passenger can come into contact with the battery or its contents.

18.21 CUT OUT DEVICE

An ignition cut-out must be fitted to operate when the driver leaves the machine. This cut-out system must interrupt the primary circuit and must be wired for both the supply and return current. The cut-out must be placed as near to the centre of the handlebar as possible and must be operated by a non-elastic string of adequate length and thickness and strapped to the driver's body. A spiral cable (similar to that of a telephone wire) of maximum 1m extended length is permitted.

Any electric fuel feed pump must be wired in such a way as to cut out if the engine cut-out device is operated.

18.22 RED WARNING LIGHT

Sidecars must be equipped for all the duration of the event with a functional rear-facing red anti-fog lamp, measuring a minimum of 30 sq.cm and producing a minimum of 1500 MCD continuous light. Pulsating lights are not permitted.

The light must be installed at least 100mm off the ground, located in the area between the back wheel and the sidecar platform.

The light must be mounted on a part of the suspended body, (not on any unsuspended parts) and ensure no obstruction from the fairing and/or the passenger.

Red lights must be switched on when a "Wet Race" is declared.

Classic or Vintage machines racing exclusively in their own race or event are exempt.

18.23 TRACTION CONTROL

Any electronic traction control system is forbidden. Wheel speed sensors are not permitted.

18.24 REAR VIEW MIRROR

External rear view mirrors having suitable dimensions and mountings may be used for closed public road races only.

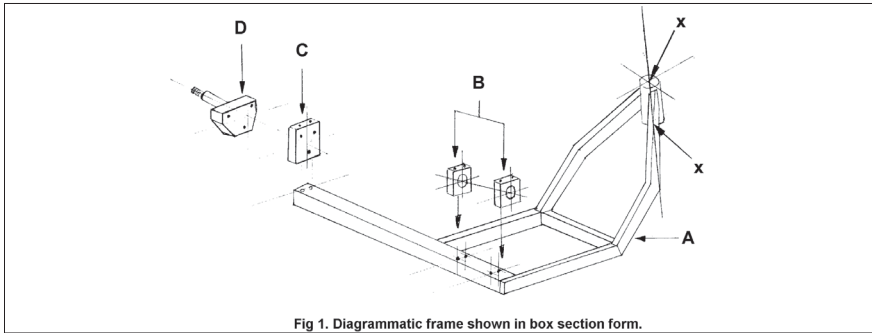

Fig 1. Diagrammatic frame shown in box section form.

SECTION 19 FORMULA 1 SIDECAR SPECIFICATION

Formula 1 Sidecars must comply with the general Sidecar specification unless changed by the following specifications:

19.1 ENGINE SPECIFICATIONS

1. Two Stroke Engines Maximum 500cc. Prototype engine design is allowed. Maximum of 4 cylinders.
2. Four Stroke Engines Motorcycles of mass production only Maximum 1000cc. Maximum 4 cylinders.
3. Balancing and Lightening are permitted.
4. Con rods may be changed, however the use of carbon or titanium is not allowed in their construction. The use of exotic materials is not allowed, (i.e. ceramics, metal matrix/aluminium beryllium) unless as fitted by manufacturer to homologated engine.
5. Piston rings and pins may be changed.
6. The original cylinder head may be modified, however the number of ports and valves must remain as originally produced by the manufacturer.
7. Camshafts may be altered or replaced. Method of cam drive must remain as originally produced by the manufacturer.
8. The Ignition/Injection Engine Control system is free.
9. Maximum of 6 speed transmission.
10. The clutch may be modified but must remain either wet or dry types as originally produced.
11. The generator and/or electric starter may be removed.
12. Carburettors may be altered or replaced.
13. The use of exotic materials is not allowed, (i.e. ceramics, metal matrix/aluminium beryllium). Unless as fitted by manufacturer to homologated engine.
14. The oil lubrication system is free.

19.2 ENGINE

Must be positioned in front of the rear wheel in such a way that the centre line of the engine shall not extend more than 160mm beyond the centre line of the rear wheel track of the motorcycle. By definition the centre line of the engine is the position midway between the centre lines of the outmost cylinders for transverse engines, or the crankshaft for in-line engines.

19.3 DIMENSIONS

Overall width Maximum 1700mm (67 ins) (including exhaust system)
Overall height Maximum 800mm (31.5) (with exception of airbox max height 950mm (37.5 ins)) Overall length Maximum 3300mm (130 ins)
Overall wheelbase Maximum 2300mm (90.5)

19.4 STEERING

The motorcycle must be steered by a handlebar. The handlebar extremities must not be lower than the front wheel spindle, (nor more than 500mm (19.7 ins) behind the front wheel spindle in the straight-ahead position) (the steering axis must not be offset more than 75mm (2.9 ins) from the front wheel centre line).

Any butt welded handle bars must be suitably gusseted.

19.5 SUSPENSION

The suspension of the front wheel must be designed so that under suspension action and in the straight ahead position, the wheel shall only move vertically and in a single plane relative to the motorcycle. The plane must be on the driving direction. This must occur without changes to the camber or the tracking. The vertical travel of the front and rear wheel spindles under suspension action must be at least 20mm (0.75 ins). The use of active suspensions is forbidden.

19.6 WHEEL PROTECTION

The rear wheel and sidecar wheel must be enclosed down to the level of the sidecar platform on the inside. The sidecar wheel on the outside must be enclosed down to the height of its axle centre-line. The rear wheel must be enclosed down to the top of the rim flange on the outside.

19.7 EXHAUST

The exhaust pipe must not extend beyond the width of the sidecar and the furthest extremity of the exhaust pipe must not exceed the vertical line drawn at a tangent to the rear edge of the sidecar bodywork.

Exhaust pipes fitted to the side of the sidecar must be covered so that it is impossible for the passenger to be burnt. The ends of the exhaust pipes fitted to the sidecar must be so positioned or protected that it is impossible for them to become entangled with another machine.

SECTION 20 PARADES AT ACU/MCRCB ROAD RACE MEETINGS

20.1 INTRODUCTION

These Standing Regulations for Parades have been established in order to provide a framework under which all Parades at ACU/MCRCB Events are to be organised.

20.2 ORGANISATION

Parades may be organised within an ACU/MCRCB permitted event. Details may be included in the Supplementary Regulations for the event or separate Parade Supplementary Regulations may be issued.

1. There must be a separate Entry Form for each Parade. An entry fee may be charged.
2. All Parades will be covered by the ACU/MCRCB Permit issued for the meeting.
3. Parades may be organised by Circuit Owners, Promoters, ACU Affiliated Clubs, MRCRB or any body or organisation appointed by the aforementioned. However, in all cases the organisation on the circuit will be carried out under the supervision of the Clerk of the Course and the Organisers of the racing programme of the event. A senior representative of the Organisers of the Parade must be present in Race Control whilst the parade is in progress.
4. The Organisers of the Race Meeting (during which the parade will take place) and the Permit

Issuing Authority must approve the Parade Supplementary Regulations and all other associated documents before these are issued to prospective entrants.

5. If the Secretary of the Meeting is responsible for the signing on of the riders he must be provided with a list of participants together with all other documentation on the day of the event.
6. The Secretary of the Parade is responsible for the signing-on procedures and the production of all other documentation.
7. Every participant in a parade is required to sign-on on the official forms provided and declare that their machine and clothing conform to the regulations.
8. The Secretary of the parade, the Organisers of the Meeting or the ACU Technical Officer may refuse the participation in the parade of any participant at any time.
9. The Secretary of the Parade is required to provide the Secretary of the meeting with a complete signing-on sheet covering every rider and passenger one hour before the start of the relevant parade.
10. Insurance cover is included as follows:
 - i) Public Liability Insurance is included in the Permit for the event.
 - ii) The Insurance Company (Brokers) will be appointed by the ACU/MCRCB.

20.3 pR5 SpECTATOR pARADES – SpEED CONTROLLED

Where an opportunity is provided for riders of road going motorcycles to participate for their own pleasure on their own machines in controlled circumstances.

1. **Machine Qualification.** Machines must be road going, no race machines are permitted. Machines must be road worthy - the decision of the technical official/organiser is final in this matter. Organisers may limit the type of machine allowed or grade the machines into separate parades.
A PR5 Parade that has Motorcycles and Scooters on track at the same time must be Speed Controlled to 60mph.
2. **Rider Qualifications.**
 1. Riders under 70 years of age must hold a current ACU Road Race Competition Licence, or a current ACU Road Race Parade Licence or a Full Class "A" DVLA motorcycle licence.
Participants (including sidecar passengers) who are 70 years of age or over must hold a current ACU Parade Licence or a current ACU Road Race Competition Licence.
 2. First time applicants for an ACU Road Race Parade Licence must hold a current Full Class "A" DVLA motorcycle licence or must satisfactorily complete an ACU Road Race Basic Rider Assessment
 3. The minimum age for participation in Parades is 14 years. Where a participant is under the age of 18 years a Parental Consent Form must also be completed.
 4. All participants must complete an Entry Form Declaration using the standard ACU wording for participation in Road Racing.
 5. Riders must be members of an ACU affiliated club.
3. **Documents.** DVLA motorcycle licence and/or ACU licence applicable to that rider must be produced at signing-on
4. **Insurance**
 1. The Insurance Company (Brokers) will be appointed by the ACU/MCRCB.
 2. Organisers of PR5 Parades are expected to pay a fee in respect of the Public Liability premium. Please contact the Road Race Department for further details.
 3. No Personal Accident insurance is included in respect of PR5 parades.
 4. No cover is included in respect of machines, clothing or other personal property etc.
5. **Clothing**
Full leather clothing (one piece or two piece zipped together) in good condition or suitable

protective motorcycle clothing, including boots and gloves, designed for road use must be worn. (i.e. no paddock jackets, jeans, trainers etc. will be allowed on the track.)

6. Safety Helmets

Safety helmets must be worn and fastened properly at all times and must be legal for road use. ACU Gold standard is recommended.

7. Identification

A suitable means of identifying approved machines, riders and passengers must be used (i.e. headlamp stickers and wristbands).

8. Technical Control

1. Participants must ensure their machines and clothing meet the conditions stated in this document.

2. An approved ACU Technical Officer will be appointed. Checks will be carried out but limited to checking documentation and Registration Numbers.

9. Briefing

1. The Clerk of the Course of the Organising Club will conduct a briefing which all riders participating in the parade must attend.

2. Failure to attend the briefing will result in disqualification unless the Clerk of the Course has previously issued a waiver in writing to any participant.

3. The briefing will include Flag Signals, Speed, Safety, the Timetable and all other general arrangements for the conduct of the Parade.

4. Riders who fall from their machine are not permitted to continue with the parade or participate in any further parades at the same meeting until passed fit by the Medical Officer and the machine re-inspected by technical control.

10. Speed

The average speed of the participants must not exceed 60mph. The speed of the parade will be dictated by the Clerk of the Course, who will take into consideration the circuit, conditions and machinery, and will be controlled by Pace Cars or Travelling Marshals. No participant is allowed to overtake a pace car or Travelling Marshal.

11. Number of riders permitted

Parades containing 60 or less riders will be controlled by two pace cars/travelling marshals, one at the front and one at the rear. Parades containing over 60 riders are permitted, but will be

controlled by one extra pace car/travelling marshals for each additional block of up to 60 riders.

20.4 pr6 CLASSIC MACHINE AND/OR RIDER PARADES

Being Parades usually organised as an integral part of a ACU/MCRCB permitted race meeting where an opportunity is provided for "Past Master" class riders to participate to celebrate past performances and/or riders of Classic machines or Machines of Historical Interest to participate for their own pleasure in controlled circumstances.

1. Non competitive

No Classic parade will include any competitive element in any circumstances.

2. Courses

Only courses licensed by the ACU/MCRCB for road racing may be used.

3. Permit and Supplementary Regulations

Parades require an ACU/MCRCB Permit which will be issued following approval of the Supplementary Regulations and Entry Forms to be issued for the event. Where a Classic Parade is to be organised as part of an ACU/MCRCB Permitted race meeting it will be held under the Permit issued for that event.

4. Machine qualification

Classic machines must be equipped with racing number plates and display the allocated riding numbers.

Machines must be examined by an ACU Technical Official. Organisers may limit the type of machine allowed or grade the machines into separate parades.

A PR6 Parade that has Motorcycles and Scooters on track at the same time must be Speed Controlled to 60mph.

5. Documents

Riders are required to provide a commentator's information sheet with the history of both themselves and their machine. Riders are also required to sign-on on the form provided by the Organising Club on the day of the event.

6. Insurance

Insurance cover is included as follows:

1. The Insurance Company (Brokers) will be appointed by the ACU/MCRCB.
2. Personal Accident benefits are included for those taking part in PR6 Parades and is limited to £10,000 Death, and £20,000 Loss of or loss of use of two limbs or the sight of two eyes, or loss of use of one limb and one eye, the loss of or loss of use of a limb or the sight of an eye. There are no weekly benefits in respect of temporary or total disablement.
3. Should any participants be found to be in breach of these Standing Regulations for Parades the Insurance arrangements stated in this article will be null and void.
4. The Insurance is for personal accident only and does not cover machine, clothing, equipment etc.
5. The Secretary of the Parade is responsible for the payment of Personal Accident Insurance premiums, which must be submitted to the Secretary of the meeting on the day of the parade at the latest. The Secretary of the Meeting is then responsible for the payment of the Insurance Premiums to the Brokers.
6. No cover is included in respect of machines, clothing or other personal property etc.

7. Rider qualification

1. Riders under 70 years of age must hold a current ACU Road Race Competition Licence, or a current ACU Road Race Parade Licence or a Full Class "A" DVLA motorcycle licence. Participants (including sidecar passengers) who are 70 or over must hold an ACU Parade Licence or a current ACU Road Race Competition Licence.
2. First time applicants for an ACU Road Race Parade Licence must hold a current Full Class "A" DVLA motorcycle licence or must satisfactorily complete an ACU Road Race Basic Rider Assessment.
3. The minimum age for participation in Parades is 14 years. Where a participant is under the age of 18 years a Parental Consent Form must also be completed.
4. All participants must complete an Entry Form Declaration using the standard ACU wording for participation in Road Racing.
5. Riders must be members of an ACU affiliated club.

8. Briefing

1. The Clerk of the Course of the Organising Club will conduct a briefing which all riders participating in the parade must attend.
2. Failure to attend the briefing will result in disqualification unless the Clerk of the Course has previously issued a waiver in writing to any participant.
3. The briefing will include Flag Signals, Speed, Safety, the Timetable and all other general arrangements for the conduct of the Parade.
4. Riders who fall from their machine are not permitted to continue with the parade or participate in any further parades at the same meeting until passed fit by the Medical Officer and the machine re-inspected by technical control.

9. Method of start

Riders will be filtered on to the circuit in small groups. Parades for "Past Masters" only may be started either singly or in small groups from the designated Starting grid at the discretion of the Organisers and where so required for the introduction of noteworthy participants to spectators.

10. Noise

The maximum noise level is 105 dB/A. Noise levels will be measured in accordance with the procedure specified in the ACU Standing Regulations for Road Racing. Exceptionally, noise levels may be increased on special occasions for the demonstration of particular riders or machines. In all such cases the permission of all appropriate sporting and civil authorities must be obtained beforehand.

11. Speed

The speed of the Parade will be determined by the Clerk of the Course who will take into consideration the circuit, conditions and machinery. Classic parades will not generally be speed restricted, but the organiser may use pace cars and/or travelling marshals as described for PR5 parades if required. The Clerk of the Course will immediately disqualify any rider deemed to be riding in an inappropriate manner by means of a Black Flag displayed at the Start and Finish line together with a board bearing the rider's number.

12. Conduct of Parades

Parades must be conducted with Officials, Marshalling and Medical services all in place.

13. Protective Clothing and Helmets

As per Road Race Standing Regulations. Riders must present themselves at Technical Control fully clothed for Parading.

14. Number of Riders permitted

The maximum number of Paraders in any session will be the same as that authorised on the ACU MRCB Circuit Licence for Official Practice.

15. Officials

The Organisers will appoint a Parade Secretary to be responsible for the proper completion of all entry forms and any other associated documents. The Club will appoint an ACU licensed Clerk of the Course to be responsible to the Stewards of the Meeting and to the Organisers for the general good management and conduct of the Parade.

SECTION 21 ORGANISATION OF OFFICIAL TEST DAYS

A day allocated for testing with no official results or timing. This may be associated with a Permitted Meeting or held under a separate Official Test Day Permit. The following conditions will apply:

21.1 ORGANISATION

This will be authorised by the issue of the Permit to the organising Club or Body.

21.2 INSURANCE

Insurance both Public Liability and Personal Accident must comply with Standing Regulations.

21.3 MEDICAL COVER

As laid down in the Minimum Requirements for Road Race Medical Services in the Road Race Safety Section of this Handbook.

21.4 OFFICIALS

There must be a minimum of 1 marshal on duty at each corner or bend. The Race Control must be controlled by officials authorised by the Permitting Body and the Regulations complied with.

21.5 RIDERS

All riders must have a valid competition licence appropriate for the machine they intend to ride. All riders must sign on prior to taking part.

21.6 JUNIOR RIDERS

For all riders under 18 years of age the following must be produced before participation:

- 1) A completed Parental Consent form.
- 2) A Temporary Discharge Form from their school or college if in full time Education.

21.7 TECHNICAL CONTROL

Riders are responsible for ensuring both machine and equipment comply with the Standing Regulations for Road Race.

21.8 ON CIRCUIT CONTROL

The Track Licence condition regarding numbers allowed onto the circuit to Practice must be complied with.

21.9 CIRCUIT

With the exception of safety and medical requirements detailed in this article the circuit must comply with the Track Licence.

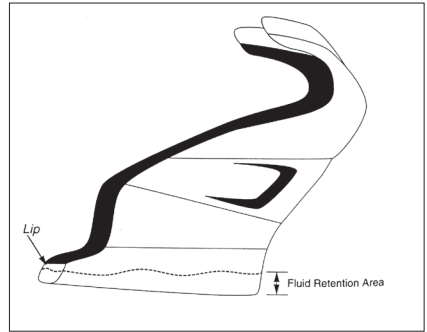
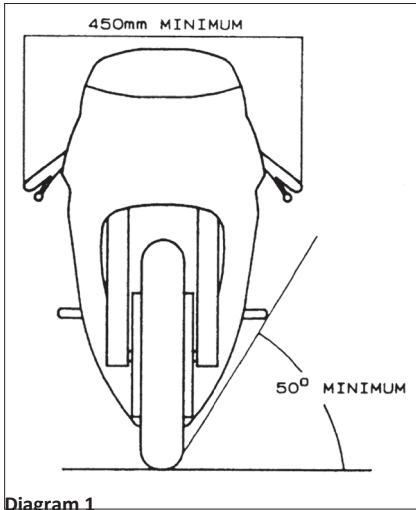

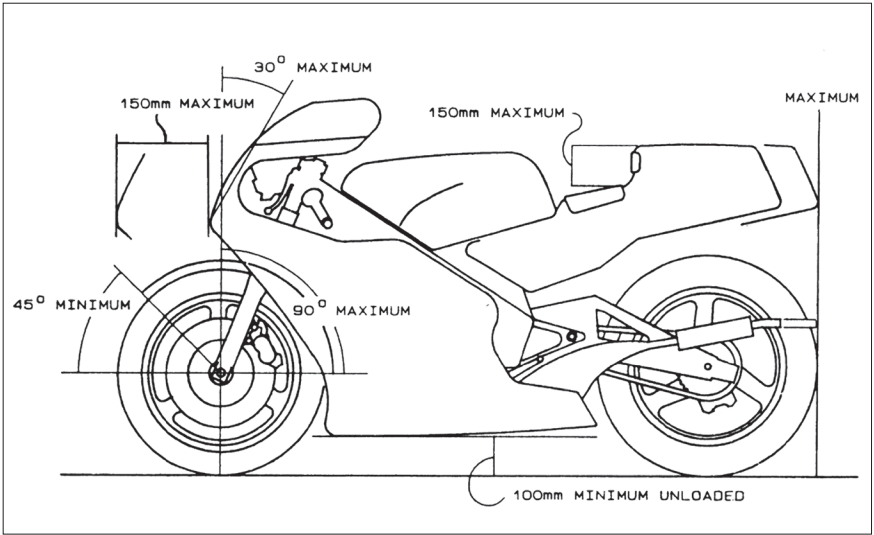

Diagram 2

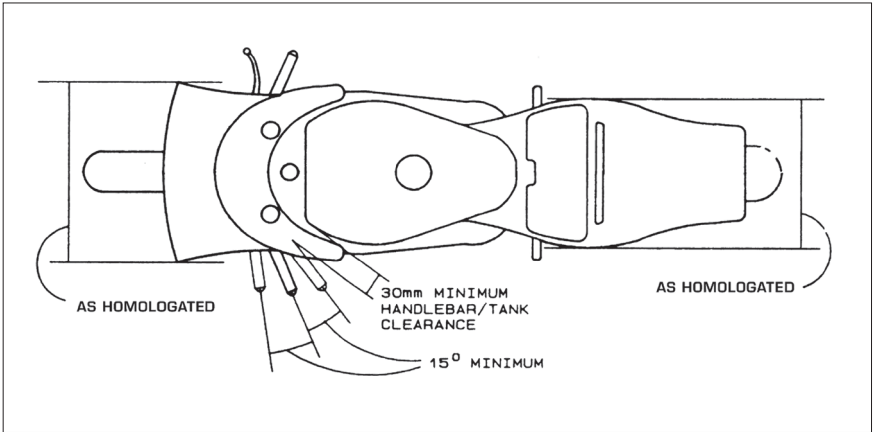
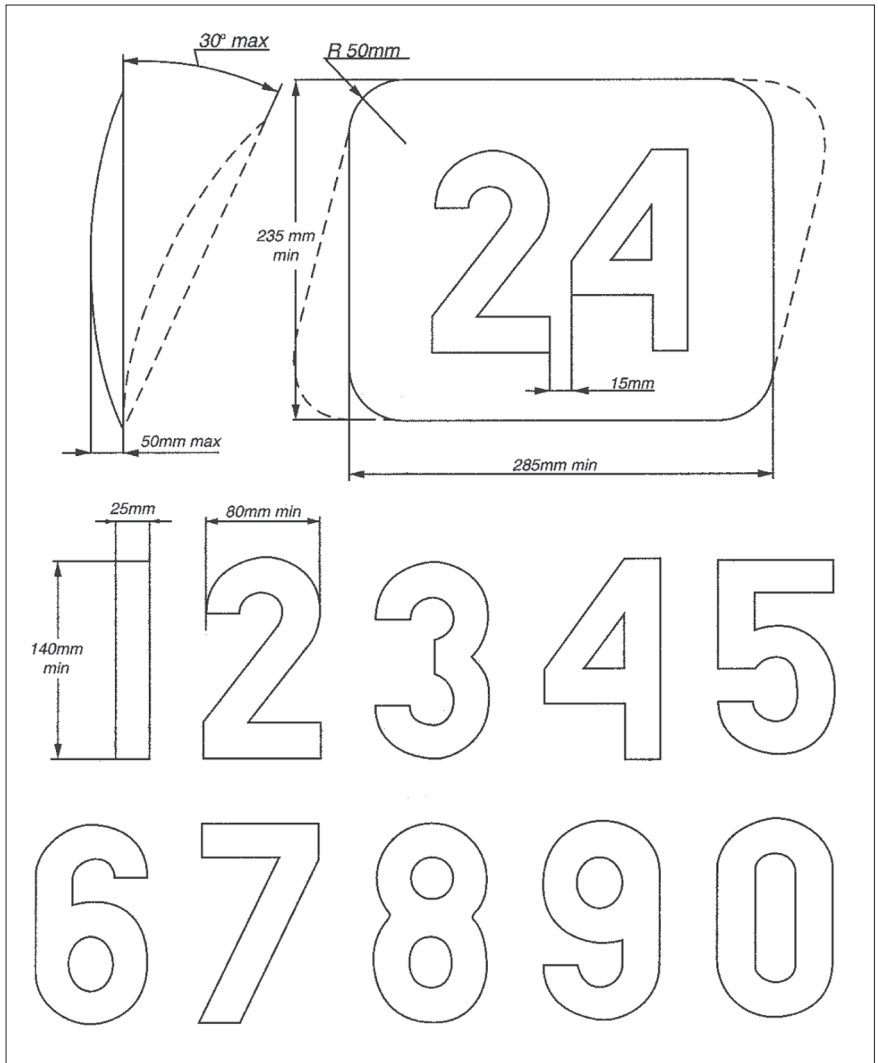

Diagram 3



Number plate

Supermoto

Standing Regulations

SECTION 1

MEETINGS

1.1	Categories Of Meetings	297
1.2	International	297
1.3	European Open	297
1.4	National	297
1.5	Open	297
1.6	Restricted	297
1.7	Eligibility Of Foreign Riders In Open And Restricted Meetings	298
1.8	Practice Meetings And Test Days	298
1.9	Conditions For Supermoto Meetings	298

SECTION 2 LICENCES – COMPETITORS

2.1	General	298
2.2	Grades	298
2.3	Lapsed Licences	299
2.4	Capacity And Licence Restrictions	299

SECTION 3 LICENCES AND REGISTRATIONS – OFFICIALS

3.1	Qualifications And Conditions	299
3.2	Supermoto Officials Who Require A Licence	299
3.3	Grades For Supermoto Clerk Of The Course	300
3.4	Supermoto Officials Who Do Not Require A Licence	300

SECTION 4 PRACTICE 301

SECTION 5 GRID POSITIONS

5.1	Positions	301
5.2	Timed Practice	301
5.3	Balloted	301
5.4	Allocated	301
5.5	Superpole	301

SECTION 6 START PROCEDURE

6.1	Start Methods	302
6.2	Procedure	302
6.3	Anticipation Of The Start	303

SECTION 7 FLAGS AND LIGHTS

7.1	Flags And Lights Used To Provide Information	303
7.2	Flags Which Convey Information And Instructions	303
7.3	Flag Dimensions	304
7.4	Flag Colours	304

SECTION 8 BEHAVIOUR DURING PRACTICE AND RACE 305

SECTION 9 INTERRUPTION OF A RACE

9.1	Interruption Of A Race	306
9.2	Interruption Of A Race After The Chequered Flag	306

SECTION 10 RE-STARTING A RACE THAT HAS BEEN
INTERRUPTED 307

SECTION 11 FINISH OF A RACE AND RACE RESULTS

11.1	Finish Of A Race	307
11.2	Chequered Flag	307
11.3	Race Results	307

SECTION 12 SAFETY

12.1	Medical Services. Minimum Requirements For Supermoto Meetings	308
12.2	Track Safety Precautions	309
12.3	Fire Extinguishers	309
12.4	Fire Extinguishers At Circuits	309
12.5	Warning And Prohibition Signs At Circuits	310
12.6	Declaration – Admission Tickets, Armbands And Passes	310
12.7	Declaration On The Official Programme	310
12.8	Signing On	310

SECTION 13 TECHNICAL SPECIFICATIONS

13.1	Classes	311
13.2	Noise Control	311
13.3	Number Plates	311
13.4	Protective Clothing	311
13.5	Helmets	312
13.6	Identification Discs	312
13.7	Body Jewellery	312

The National Sporting Code of the ACU and the Standing Regulations together with the Supplementary Regulations and any Final Instructions shall apply to all Supermoto Races held under an ACU Permit.

SECTION 1 MEETINGS

1.1 CATEGORIES OF MEETINGS

- International Meetings
- European Open Meetings
- National Meetings
- Open Meetings
- Restricted Meetings

Permits for all Supermoto competitions are issued by ACU Headquarters.

1.2 INTERNATIONAL

1. The Permit shall be issued by the ACU Headquarters for a meeting inscribed on the International Calendar of the FIM and having an FIM International Meeting Number (IMN).
2. An International meeting is open to Entrants and Riders of more than one nation who must hold an International Licence or a National Licence issued by the ACU valid for the particular meeting concerned.
3. All riders not holding a Licence issued by the ACU or SACU must carry proof of Insurance and a written Start Permission document issued by their FMN.

Note: This includes all riders holding a licence issued by the MCUI.

1.3 EUROPEAN OPEN

1. The permit shall be issued by ACU Headquarters for a meeting inscribed on the Calendar of the Fédération Internationale de Motocyclisme Europe (FIME) and having a European Meeting Number (EMN).
2. A European Open meeting is open to Entrants and Riders of more than one European nation who must hold the appropriate Competition Licence valid for the particular meeting concerned.
3. All riders not holding a Licence issued by the ACU or SACU must carry proof of Insurance and a written Start Permission document issued by their FMN.

Note: This includes all riders holding a licence issued by the MCUI.

1.4 NATIONAL

1. The Permit shall be issued by the ACU Headquarters.
2. A National meeting is open to Entrants and Riders who are the holders of a National or International Licence valid for the particular meeting concerned issued by any Federation.
3. All riders not holding a Licence issued by the ACU or SACU must carry proof of Insurance and a written Start Permission document issued by their FMN.

Note: This includes all riders holding a licence issued by the MCUI.

1.5 OPEN

1. An Open permit is issued by ACU Headquarters.
2. An Open meeting is open to Entrants and Riders who hold a valid ACU or SACU Licence for the meeting concerned.

1.6 RESTRICTED

1. A Restricted Permit is issued by ACU Headquarters.
2. A Restricted meeting is open to Entrants and Riders who hold a current ACU Licence valid for the meeting concerned.

3. The Supplementary Regulations issued for the event must specify all restrictions and requirements of eligibility.

1.7 ELIGIBILITY OF FOREIGN RIDERS IN OPEN AND RESTRICTED MEETINGS

1. The Supplementary Regulations issued for the event must specify the licence qualification and eligibility requirements of foreign riders.
2. All riders must have a current Licence and Start Permission from their own Federation valid for the event.

1.8 PRACTICE MEETINGS AND TEST DAYS

1. Permits for Practice Meetings and Test Days may be issued on application to the Permit Issuing Authority.
2. No such event may be held unless the appropriate Permit and Insurance has been issued.

1.9 CONDITIONS FOR SUPERMOTO MEETINGS

1. The ACU Road Race Committee must approve the Organiser.
2. The Venue must hold a current Track Licence or Track Certificate issued by the ACU Road Race Committee.
3. The ACU Secretariat must approve the Supplementary Regulations for the event and issue an ACU Permit prior to publication and circulation.
4. For all ACU Championships an ACU decal, supplied by the ACU Secretariat, must be displayed on each machine. Any rider not complying will be disqualified from the results of the race.
5. All officials and marshals must remain at the circuit and available to the Clerk of the Course and the Stewards during the period provided for the lodging of a Protest that period.
6. On venues where the average lap speed is expected to be greater than 65kph and the maximum speed is greater than 130kph the Clerk of the Course must be a Road Race National B official or above. This will be known as Supermoto R.
7. On venues where the average lap speed is expected to be less than 65kph and the maximum speed is less than 130kph the Clerk of the Course can be a National MX or Road Race National C official or above. This will be known as Supermoto X.
8. A Riders Briefing will be conducted by the Clerk of the Course before the start of practice or as detailed in the Final Instructions.

SECTION 2 LICENCES – COMPETITORS

2.1 GENERAL

1. To participate in Supermoto events an annual Licence issued by the ACU is required. Residents in Scotland apply to the Scottish ACU.
2. A Licence can be upgraded at any time during the year.
3. The parent or legal guardian must accompany all competitors, or participants in parades, under 18 years of age to every meeting. This person must attend at signing-on and be present throughout the meeting.

2.2 GRADES

1. **Clubman** Entry level for all first time applicants.
2. **National** After competing and finishing in 10 races at 10 separate race days at 3 different venues during the current year and preceding 3 years Clubman Competitors may apply to be upgraded to a National licence.
3. **International** National licence holders who have held their National licence for 12 months and who have competed at a minimum of 3 meetings in the previous 12 months may apply for an FIM Non-Championship International licence.

A medical examination is required.

4. **International Championship** National licence holders who have held their National licence for 12 months and who have competed at a minimum of 3 meetings in the previous 12 months may apply for a Championship licence as described in the appropriate Sporting Code of the FIME or FIM.

A medical examination is required.

2.3 LApSED LICENCES

Licence holders who have allowed their licence to lapse for more than 5 years will be issued with a clubman licence.

2.4 CAPACITY AND LICENCE RESTRICTIONS

For each category the tables indicate the minimum licence requirements for their specified ages and machines.

Min Age	Grade	Capacity/Machine
11 yrs	All	up to 125cc two stroke or 250cc four stroke.
14 yrs	All	up to 250cc two strokes and 450cc four strokes.
16 yrs	All	up to 750cc four strokes.

Important Notice If a participant is under 18 years of age he/she must be accompanied to every meeting by their Parent or Legal Guardian. The Parent or Legal Guardian must attend signing on with the competitor and be available for the duration of the meeting.

SECTION 3 LICENCES AND REGISTRATIONS – OFFICIALS

3.1 QUALIFICATIONS AND CONDITIONS

Supermoto Officials are divided into two categories:

Those that are Licensed and those that are Registered. Fees may be charged in respect of any Licences or Registration or for the appropriate form of identification issued.

Licences: Senior Supermoto Officials are required to hold an ACU Licence of the appropriate Grade for the performance of their duties.

Registration: A Register is maintained of Officials not required to hold a Licence.

3.2 SUPERMOTO OFFICIALS WHO REQUIRE A LICENCE

See Note Below Attendance at Seminar/Training Session

Clerk of the Course	1	Every third year maximum
Chief Steward	2	Every third year maximum
Chief Technical Officer	3	Every third year maximum
Sound Inspector		Required for First Issue only
Measurer	4	Required for First Issue only
Timekeeper	5	Equipment and operators check

All the above licences are valid for 3 years.

Clubs and Centres shall only nominate candidates whose aptitude and integrity for the position they can fully justify. Official ACU approval and the issue of a Licence is only after the candidates have proved to be competent according to the special requirements for each discipline. The respective Committees and Panels organise Seminars that are compulsory for certain Officials.

3.3 GRADES FOR SUPERMOTO CLERK OF THE COURSE

1. Probationary
Any club may nominate a Probationary Clerk of the Course. Such a Registered Official may only act as an Assistant Clerk of the Course at a Closed to Club event.
2. Road Race National Grade C or National Grade A Motocross
A Clerk of the Course who may officiate at a Supermoto X meeting. May act as Deputy or Assistant Clerk of the Course at a Supermoto R Meetings.
3. Road Race National Grade B
A Clerk of the Course who may officiate at a Supermoto R meeting.

Note 1 Clerk of the Course

Age Limits: Licences for Clerks of the Course who have attained their 70th birthday will be reviewed annually. Officials will be required to satisfactorily attend a seminar annually. The issuing of a licence will be subject to Road Race Committee approval.

Note 2 Chief Steward

Grading: There is only one grade of Steward's Licence for all Road Race disciplines.

Age Limits: Stewards may not normally officiate beyond the end of the season in which they attain their 70th birthday. The Road Race, Drag and Sprint Committee will review Stewards who reach the age of 70 for appointments on an annual basis.

Note 3 Chief Technical Officer

The Chief Technical Officer will be licensed by the Technical Panel to be in charge of the Technical Control at an event. The Technical Panel may restrict the disciplines of licence holders.

Note 4 Measurer

The Measurer is required for ACU National Championships and National events. The Licence is issued by the Technical Panel and may be restricted by discipline.

Note 5 Timekeepers

Will be required to pay for their Licence.

Licence Fees:

All licences (exception Timekeeper's licences) will be issued, free of charge, for a period of three years. No fee will be charged for attendance at all Seminars organised by the Road Race Drag and Sprint Committee or the relevant Panel with the exception of FIM Seminars.

3.4 SUPERMOTO OFFICIALS WHO DO NOT REQUIRE A LICENCE

Registration of the officials and marshals below will be renewed annually and they will receive an appropriate form of identification from the ACU.

See Note Below Attendance at Seminar/Training Session

Incident Officer	1	Refer to Note 1
Secretary of the Meeting	2 and 4	Will receive Training at meetings and if required at Regional or ACU HQ Seminars
Technical Official		Will receive training via the Chief Technical Officer at meetings. May attend Regional Training Seminars
Club Stewards	3	May attend Regional or ACU HQ Seminars for information purposes
Chief Marshal		May receive training at ACU HQ or Regional Training Days
Marshal		May receive training at Regional Training days and at meetings via the Chief Marshal

Note 1 Incident Officer

Will collate all information and documentation, and prepare reports relating to serious accidents and to all incidents involving Officials or Spectators.

For 2019 it is recommended that the Incident Officer is at least a Probationary Clerk of the Course or has attended an Incident Officer Seminar.
For 2020 and onwards the Incident Officer will be required to hold at least a Probationary Clerk of the Course licence or have attended an Incident Officer Seminar.

Note 2 Secretary of the Meeting

Will be responsible for all administration connected with the organisation of a meeting.

Note 3 Club Stewards

Will together with the Chief Steward form the judicial authority over the running of the meeting.

Note 4 Secretary of the Meeting Registration

Currently there is no requirement for these officials to be Registered for Road Race Disciplines.

SECTION 4 PRACTICE

4.1 A MINIMUM PERIOD OF TIME MUST BE PUT ASIDE FOR THE PRACTICE SESSIONS AND MENTIONED IN THE SUPPLEMENTARY REGULATIONS OF THE MEETING.

1. Riders will commence practice under the instructions of the Start Officials.
2. The duration of practice will commence from the time the 1st rider joins the circuit.
3. The end of practice will be indicated by the waving of a chequered flag at which time the pit exit will be closed. A rider's time will continue to be recorded until he passes the finish line after the allotted time has lapsed.
4. If practice is interrupted due to an incident or any other reason then a red flag will be displayed at the start line and at marshals posts. All riders must return slowly to the pit lane or as otherwise instructed by the Marshals under the direction of the Clerk of the Course.
5. When the practice is restarted the time remaining will be decided by the Clerk of the Course.

SECTION 5 GRID POSITIONS

5.1 POSITIONS

1. Pole position, and the configuration of the grid, will be determined at the time of the Track Inspection.
2. Grid positions will be established according to the provisions of the Supplementary Regulations.

5.2 TIMED PRACTICE

1. Where timed practice is used and identical times are recorded by more than one rider in the official qualifying practice session for the race the rider first setting such a time will receive the better starting position.
2. A qualifying maxima may be specified in the Supplementary Regulations.

5.3 BALLOTTED

1. Where the Organiser decides that the grid positions will be by ballot this must be conducted by the competitors at the meeting.

5.4 ALLOCATED

1. Organisers wishing to allocate grid positions will specify this and the method to be adopted in the Supplementary Regulations.

5.5 SUPERPOLE

1. The riders, as detailed in the Supplementary Regulations, will take part in the Superpole.
2. Each Rider will have one warm-up lap, one timed lap and one slowing down lap.
3. The Rider with the fastest timed lap will have pole position for the race, the second fastest the

second grid position and so on. Any rider that does not complete the Superpole will start the race from the last grid position allocated to Superpole riders.

4. If there is a tie for positions the fastest lap during the normal timed qualifying will be used.

SECTION 6 START PROCEDURE

6.1 START METHODS

Races may be started by one of the following methods:

1. Group Starts
2. Interval Starts

Where competitors are started individually or in groups at pre-determined intervals. e.g. Superpole. Starts will be made with engines running unless specified otherwise in the Supplementary Regulations.

6.2 pROCEDURE

The final choice of motorcycle to be used in a race should be made before the motorcycle is brought into the waiting area.

1. 15 minutes before the start of the Warm-Up laps: The entrance to the waiting area is open. The motorcycle of each rider must be placed in the waiting area.
2. 3 minutes before the start of the Warm-Up laps: Sound or whistle signal. Riders may leave the waiting area to take their positions on the starting grid. The entrance from the paddock to the waiting area closes. The penalty for arriving late at the waiting area is loss of starting position. Late arriving motorcycles will be held in the waiting area. The riders concerned must obey the instructions from the officials.
3. 1 minute before the start of the Warm-Up laps:
 1. The entrance from the waiting area to the grid is closed.
 2. On instructions from the Start Line Official the riders will proceed on the 2 compulsory warm-up laps. Any rider not completing the warm-up laps will start from the back of the grid.
 3. The Start Line Official will stand at the front of the starting grid displaying a red flag. A second Official will stand at the back of the starting grid with a green flag and display it when the grid is complete.
 4. Any rider who encounters mechanical problems during the warm-up laps may go to the repair zone and make repairs.
 5. On returning to the grid the riders must take their position with the front wheel of their motorcycle up to the line defining their starting position and keep their engines running.
 6. Once a rider has taken his allocated position on the grid, he cannot change it, return to the pit lane or receive assistance prior to the start.
 7. When all the riders have taken up their grid positions the Official at the rear of the grid will raise the green flag.
 8. Any rider who arrives back from the warm-up laps after the Official at the rear of the starting grid has raised the green flag, will be considered a "late arrival" and start the race from a position behind the Official at the rear of the grid.
 9. If a rider has mechanical problems at the starting grid, he must remain on his motorcycle and raise his arm.
 10. Any rider who is unable to start his motorcycle within a reasonable time, must obey the instructions of the officials and remove his motorcycle from the grid.
 11. If he manages to start his machine he may start the race after all other machines have left the grid at the start of the race.
 12. The Startline Official moves to the side of the track, holding up the red flag.
 13. The Startline Official puts down the red flag and the start light sequence begins.

14. The red lights come on and remain on for upto five seconds the red lights will then be switched off and the Race starts.
15. Any alteration to this Start Procedure must be conveyed to the riders at the Riders Briefing.

6.3 ANTICIPATION OF THE START

1. Anticipation of the start is defined as the motorcycle moving forward when the Red Lights are on.
2. Any competitor who takes up the incorrect grid position will also be adjudged to have anticipated the start.
3. The Clerk of the Course will award a time penalty of up to 20 seconds to any competitor who anticipates the start. The decision as to an anticipated start is a matter of fact with no right of appeal.

SECTION 7 FLAGS AND LIGHTS

Marshals and other officials display flags or lights to provide information and/or convey instructions to the riders:

7.1 FLAGS AND LIGHTS USED TO pROVIDE INFORMATION

1 GREEN FLAG

1. The track is clear. This flag must be shown motionless at each flag marshal post for the first lap of each practice session and of the warm up, for the sighting lap(s) and for the warm up lap.
2. This flag must be shown motionless at the flag marshal post immediately after the incident that necessitated the use of one or more yellow flags.
3. This flag must be waved by the starter to signal the start of the warm up lap.
4. When the pit-lane exit is open, this flag must be waved at the pit-lane exit.

2 GREEN LIGHT

1. This light must be switched on at the pit lane exit to signal the start of each practice session and of the warm up, the start of the sighting lap(s) and the start of the warm up lap.

3 BLUE FLAG

1. Shown waved at the flag marshal post, this flag indicates to a rider that he is about to be overtaken.
2. During the practice sessions, the rider concerned must keep his line and slow down gradually to allow the faster rider to pass him.
3. During the race, the rider concerned is about to be lapped. He must allow the following rider(s) to pass him at the earliest opportunity.
4. Any infringement of this rule will be penalised with one or more of the following penalties:
fine
- disqualification - withdrawal of Championship points.
5. At all times, this flag will be shown waved to a rider leaving the pit lane if traffic is approaching on the track.

4 CHEQUERED BLACK/WHITE FLAG

1. This flag will be waved at the finish line on track level to indicate the finish of race or practice session.

7.2 FLAGS WHICH CONVEY INFORMATION AND INSTRUCTIONS

1 YELLOW FLAG

1. Shown waved at each row of the starting grid, this flag indicates that the start of the race is delayed.

2. Shown waved at the flag marshal post, this flag indicates that there is a danger ahead. The riders must slow down and be prepared to stop.
3. Overtaking is forbidden up until the point where the green flag is shown.
4. Any infringement of this rule during a practice session will result in the cancellation of the time of the lap during which the infraction occurred.
5. In case of infringement of this rule during the race, a time penalty will be imposed.
6. In both cases, further penalties (such as fine – suspension) may also be imposed.
7. During the final inspection lap, this flag must be waved at the exact place where the flag marshal will be positioned during the practices, warm ups and races.

2 RED FLAG AND RED LIGHTS

1. When the race or practice is being interrupted, the red flag will be waved at each flag marshal post and the red lights around the track will be switched on.
2. Riders must return slowly to the pits.
3. When the pit-lane exit is closed, this flag will be shown motionless at the pit-lane exit and the light will be switched on. Riders are not allowed to exit the pit lane.
4. Any infringement of this rule will be penalised with one or more of the following penalties: fine – disqualification – withdrawal of Championship points – suspension.
5. The red flag will be shown motionless on the starting grid at the end of the sighting lap(s) and at the end of the warm up lap(s).
6. The red flag may also be used to close the track.
7. The red lights will be switched on at the start line for up to 5 seconds to start each race.

3 BLACK FLAG

1. This flag is used to convey instructions to one rider only and is displayed motionless at each flag marshal post together with the rider's number.
2. The rider must stop at the pits at the end of the current lap and cannot restart.
3. Any infringement of this rule will be penalised with one or more of the following penalties: fine – disqualification – withdrawal of Championship points – suspension.

4 BLACK FLAG WITH ORANGE DISK (RADIUS 40 CM)

1. This flag is used to convey instructions to one rider only and is displayed motionless together with the rider's number.
2. This flag informs the rider that his motorcycle has mechanical problems likely to endanger himself or others, and that he must immediately leave the track.
3. Any infringement of this rule will be penalised with one or more of the following penalties: fine – disqualification – withdrawal of Championship points – suspension.

7.3 FLAG DIMENSIONS

The flag dimension should be approximately 80cms in the vertical and 100cms in the horizontal.

7.4 FLAG COLOURS

The Pantones for the colours are as follows:
Black: Pantone Black C
Blue: Pantone 286C or
298C
Red: Pantone 186C
Yellow: Pantone Yellow
CGreen: Pantone 348C

SECTION 8 BEHAVIOUR DURING PRACTICE AND RACE

8.1 RIDERS MUST OBEY THE FLAG SIGNALS, THE LIGHT SIGNALS, AND THE BOARDS WHICH CONVEY INSTRUCTIONS. ANY INFRINGEMENT TO THIS RULE WILL BE PENALISED ACCORDING TO THE PROVISIONS OF ARTICLE 7.2.

1. Riders must ride in a responsible manner which does not cause danger to other competitors or participants, either on the track or in the pit-lane.
Any infringement of this rule will be penalised with one or more of the following penalties:
fine
– time penalty – disqualification – withdrawal of Championship points – suspension.
2. Riders should use only the track and the pit-lane. However, if a rider accidentally leaves the track then he may rejoin it at the place indicated by the marshals or at a place which does not provide an advantage to him. Any infringement of this rule during the practices or warm up will be penalised by the cancellation of the lap time concerned and during the race, by a time penalty.
Further penalties (such as fine – disqualification – withdrawal of Championship points) may also be imposed.
3. Any repairs or adjustments along the race track must be made by the rider working alone with absolutely no outside assistance. The marshals may assist the rider to the extent of helping him to lift the machine and holding it whilst any repairs or adjustments are made. The marshal may then assist him to re-start the machine.
4. If the rider intends to retire, then he must park his motorcycle in a safe area as indicated by the marshals.
5. If the rider encounters a problem with the machine which will result in his retirement from the practice or the race, then he should not attempt to tour at reduced speed to the pits but should pull off the track and park his machine in a safe place as indicated by the marshals.
6. Riders are not permitted to return slowly to the pits for remedial work.
7. Riders may enter the pits during the race, but taking the motorcycle inside the pit box is not permitted. Any infringement of this rule will be penalised with a disqualification.
Refuelling is strictly prohibited.
Riders who stop their engines in the pits may be assisted to re-start their motorcycle by the mechanics.
8. Riders are not allowed to transport another person on their machine or to be transported by another rider on his machine.
9. Riders who fall from their machine may remount and continue unless the Incident Marshal considers the machine too damaged or the Medical Personnel consider the rider unfit to continue. In this situation riders who fall from their machine are not permitted to continue with the practice or race until passed fit by the Medical Officer and his machine re-inspected by technical control.
10. Riders must not ride or push their motorcycles in the opposite direction of the circuit, either on the track or in the pit lane, unless doing so under the direction of an Official.
11. No signal of any kind may pass between a moving motorcycle and anyone connected with the motorcycle's entrant or rider, save for the signal from the time keeping transponder, or legible messages on a pit board or body movements by the rider.
12. The carrying of on board cameras is only permitted with the prior approval, in writing of the Clerk of the Course. The installation of the camera must be approved by the Chief Technical Officer. Automatic lap timing devices, provided they do not disrupt official timekeeping methods, are not considered as telemetry.
13. A speed limit may be imposed in the Pit Lane.
1. Any rider found to have exceeded the limit during the practice will be subject to a penalty as described in the Supplementary Regulations.

2. Any rider who exceeds the pit lane speed limit during a race will be penalised with a time penalty as described in the Supplementary Regulations.
3. The Clerk of the Course must communicate the offence to the pit of the rider.
14. In the interest of safety, a rider may not stop his machine on the racing surface during the slow down lap, (exception see Art 8.16) when returning to the pits after the chequered flag.
15. Stopping on the track during practices and races is forbidden. (exception see Art 8.16)
16. During the practice sessions and warm ups, practice starts are permitted, when it is safe to do so, at the pit lane exit before joining the track and after the chequered flag is shown at the end of practice sessions and warm ups, when it is safe to do so.
These practice starts must take place off the racing line.
17. The spinning of rear wheels (burn-outs) is strictly forbidden. Breach of this rule will result in a penalty of disqualification.
18. Any competitor who in any ACU or MCRCB Permitted Event participates on a machine for which he is not eligible through age or licence restrictions will be penalised by a fine of £500.00 and a suspension for one year from the date of the hearing.
19. Riders who enter the Paddock during a race will be deemed to have retired from the race.

SECTION 9 INTERRUPTION OF A RACE

9.1 INTERRUPTION OF A RACE

If the Clerk of the Course decides to interrupt a race, then red flags will be displayed at the finish line and at all marshals' posts and he will switch on the red lights around the circuit, where available.

1. Riders must immediately slow down and return to the pit lane, or as directed by the marshals, upon instructions from the Clerk of the Course.
2. Only riders still racing when the red flag is displayed will be counted as finishers.
3. The results will be the results taken at the last point where the leader had completed a full lap without the red flag being displayed.
4. If the results show that less than three laps have been completed by the leader of the race then the race will be null and void and a completely new race will be run.
5. If less than 50% of the race has been completed there will be a new race over a distance decided by the Clerk of the Course.
6. The grid will be in the order of the last time riders crossed the finish line before the red flag was displayed. Riders will return to the Pit Lane, they may change motorcycles. The Clerk of the Course may disqualify any riders who in his opinion caused the race to be interrupted.
7. If it is found impossible to restart the race, then the results will count and half Championship points will be awarded.
8. If more than 50% of the race distance has been completed by the leader when the red flag is displayed the race will be considered completed. The Clerk of the Course may disqualify any riders who in his opinion caused the race to be interrupted.

9.2 INTERRUPTION OF A RACE AFTER THE CHEQUERED FLAG

If the race is interrupted after the chequered flag, the following procedure will apply:

1. For all the riders to whom the chequered flag was shown before the interruption, a partial classification will be established at the end of the last lap of the race.
2. For all the riders to whom the chequered flag was not shown before the interruption, a partial classification will be established at the end of the penultimate lap of the race.
3. The complete classification will be established by combining both partial classifications as per the lap/time procedure.

SECTION 10 RE-STARTING A RACE THAT HAS BEEN INTERRUPTED

10.1 IF A RACE HAS TO BE RE-STARTED, THEN IT WILL BE DONE AS QUICKLY AS POSSIBLE, CONSISTENT WITH TRACK CONDITIONS ALLOWING. AS SOON AS THE RIDERS HAVE RETURNED TO THE PITS THE CLERK OF THE COURSE WILL ANNOUNCE A TIME FOR THE NEW START PROCEDURE TO BEGIN WHICH, CONDITIONS PERMITTING, SHOULD NOT BE LATER THAN 10 MINUTES AFTER THE INITIAL DISPLAY OF THE RED FLAG.

1. The results of the first race must be available to teams before the second part of a race can be started.
2. The start procedure will be identical to a normal start with sighting lap(s), warm-up lap etc.
3. Conditions for the re-started race will be as follows:
 1. Only riders who are classified as finishers in the first race may re-start.
 2. Motorcycles may be repaired or changed. Refuelling is permitted.
 3. The race distance will be announced by the Clerk of the Course.
 4. The grid position will be based on the finishing order of the first race.

SECTION 11 FINISH OF A RACE AND RACE RESULTS

11.1 FINISH OF A RACE

1. When the leading rider has completed the designated number of laps for the race, he will be shown a chequered flag by an official standing at the finish line, at track level.

11.2 CHEQUERED FLAG

1. The chequered flag will continue to be displayed to the subsequent riders.
2. When the chequered flag is shown to the leading rider, no other rider will be permitted to enter the track from the pit lane.
3. In case of a photo-finish between two, or more, riders, the decision shall be taken in favour of the competitor whose front wheel leading edge crosses the plane of the finish line first. In case of ties, the riders concerned will be ranked in the order of the best lap time made during the race.
4. The Clerk of the Course may require machines to be presented for post race/practice verification. Where this is required the competitors must be informed before the start of the race or practice session that they must attend the Parc Ferme. Presentation of the machine will imply that it fully complies with the regulations.

11.3 RACE RESULTS

1. The results will be based on the order in which the riders cross the line and the number of laps completed.
2. To be counted as a finisher in the race and be included in the results a rider must:
 - a - Complete 75% of the race distance.
 - b - Cross the finish line on the race track (not in the pit lane) within two minutes of the race winner. The rider must be in contact with his machine.
3. A new lap record for a circuit can only be established by a rider during a race.
4. Both for practice and for race, the lap time is the subtraction of the time between two consecutive crossings of the finish line painted on the track.

SECTION 12 SAFETY

12.1 MEDICAL SERVICES. MINIMUM REQUIREMENTS FOR SUPERMOTO MEETINGS

	PERSONNEL			VEHICLES		
	Doctors MO	Paramedic(s) PM	First Aid personnel	Ambulance(s)	Fast Intervention Vehicle	Special Notes
Supermoto (R)	1 MO		2	1	1	
Supermoto (X)		1PM	2	1		(i)
Supermoto (R) Test Day	1 MO		2	1		

The following applies to all events run under this code.

- Medical Officer (MO) – Doctor** A medical practitioner (doctor) fully registered with the General Medical Council (GMC), and holding appropriate personal medical malpractice insurance cover (excludes NHS Crown Indemnity).
- Paramedic (PM)** A State Registered Paramedic with the HPC (Health Professions Council) Paramedics must have appropriate personal medical malpractice insurance cover.
- Ambulance** A vehicle registered as an ambulance with the DVLA (Driver and Vehicle Licensing Agency) and registered with CQC if appropriate. An ambulance must have an appropriately qualified driver to transport a casualty under blue lights. It must be equipped with the FIM minimum equipment regulations for a type C vehicle; that is:
Medical: A stretcher (preferably standardised), oxygen supply, apparatus to immobilise limbs and vertebral column. First aid medicaments and materials.
Technical: Radio communication. Visible and audible signals.
Staffing: An ambulance must be staffed by 2 First Aid Personnel (who can be two of the minimum First Aid Personnel required in the table).
 An ambulance may act as a Medical Centre BUT if so it must be a vehicle additional to the minimum ambulance requirement.
- First Aid Personnel** A person holding a current certificate of First Aid competency. (Where an event is open to the public event organisers should ensure that all First Aid personnel are insured against malpractice for the event concerned)
 Special Note (i) The minimum medical requirements specific for this discipline also apply to associated Test Days.
- Medical Examination** At any time during a meeting the Clerk of the Course may require a competitor to undergo a medical examination to determine his fitness to ride. The decision of the medical officer is final without right of appeal.
- Concussion/suspected concussion** If a competitor is involved in an incident which results in him being diagnosed by the Medical Officer/Paramedic as suffering from concussion/suspected concussion, the rider is not permitted to participate any further in that event.
 Organisers are to notify ACU Head Office as soon as possible of any concussion/suspected concussion injuries and then will subsequently:
 - Place the rider on the ACU Stop List
 - Inform Organisers of forthcoming events that the Rider has suffered a concussion/ suspected concussion injury and is therefore placed on the ACU Stop List
 - Inform the Rider that he needs to see a Doctor and obtain a letter/doctor's certificate which confirms he is fit to resume competitive racing/participate in a practice/test session.

The recovery time for anyone diagnosed with concussion/suspected concussion is as follows:

- Over 20 years: Excluded immediately and suspended for a period of nine days.
- 16–19 years: Excluded immediately and suspended for a period of twelve days.
- 15 and under: Excluded immediately and suspended for a period of twenty three days.

The rider is not permitted to ride during the obligatory suspended periods outlined above and then only once he is in possession of a doctor's certificate/letter after the suspended period has expired.

A rider may be signed off to ride by the CMO at an event once he has observed the obligatory suspended period outlined above.

If a competitor has been injured on a Saturday and is suffering from concussion/suspected concussion, and the Organiser is aware that the rider was intending to ride or is scheduled to ride somewhere else the next day, the Organiser will inform the Organiser of the event being held the next day so they are aware of the rider's injuries and as such he is prevented from participating in that event.

12.2 TRACK SAFETY PRECAUTIONS

1. The safety precautions of circuits will be as laid down for each permanent course licence or temporary course certificate following an inspection of the course.
2. It should be generally realised that the organisers of speed events have a legal responsibility to the general public and therefore it is the duty of these organisers to ensure that all reasonable precautions are taken to protect the public.
3. Whilst organising clubs are insured under the Promoters Third Party Policy in respect of their legal liability, it is a condition of the policy that the promoters of an event must comply strictly with the National Sporting Code and any additional requirements as may be specified by the Permanent Course Licence or Temporary Course Certificate. Clubs failing to do so stand in grave danger of any claims being repudiated to the club by the insurers under the terms of the policy covering legal liability.
4. The safety precautions to be adopted are provided with the Permanent Course Licence or Temporary Course Certificate for the particular course but the following general requirements must be observed.
5. The attention of organisers is drawn to the provision of the NSC which stipulates that no alteration of the requirements contained in the Permanent Course Licence or Temporary Course Certificate shall be made without the prior approval, in writing, of the ACU.
6. It is recognised that circumstances may arise in which it is necessary to make certain alterations to the course on the day of the meeting but any such alterations must be approved by the Stewards of the Meeting and details given in their report to the authority granting the permit.

12.3 FIRE EXTINGUISHERS

Each working vehicle in the Paddock must have a 2kg (minimum) dry powder fire extinguisher available for immediate use. This extinguisher must show the date of the last annual inspection. Noncompliance with this regulation will incur a penalty imposed by the Clerk of the Course.

12.4 FIRE EXTINGUISHERS AT CIRCUITS

At all race and speed events, there must be a valid certificate, issued annually immediately prior to the start of each season's racing by the manufacturer or his agent, to the effect that all fire extinguishers are in effective working order. This certificate must be available for inspection by the Stewards. All fire posts must be clearly marked. In addition to the fire equipment at each post there must be:

1. Fire extinguishers in the paddock and assembly area.
2. At least two fire extinguishers in the Technical Control Area.
3. Fire extinguishers in every medical room/centre.
4. In the case of National or lesser events during which machines may be refuelled and more than five gallons (22 litres) of fuel is held in any one pit, there shall be a minimum of one fire tender and crew in attendance, appropriately equipped and with immediate access to the pit area. International events must comply with appropriate FIM requirements.

12.5 WARNING AND PROHIBITION SIGNS AT CIRCUITS

1 WARNING NOTICES

The following requirements regarding the display of Warning notices are applicable to all Road Racing events.

1. **WARNING NOTICE (A)** (29 × 20 inches.) Warning notices as detailed below must be displayed on each side of every entrance to the course, including the entrance to car parks and paddock. These notices must be prominently displayed where they can be easily read by the public before any admission charge is paid, or where no admission charge is made before entry is gained into the circuit.
Where it is not possible to define the limits of the site and to control admission of the public (e.g. War Department and heath land) warning notices must be profusely displayed around the course and also in the car parks.
2. **WARNING NOTICE (B)** (20 × 15 inches.) Those parts of the course to which the public may be admitted and where it is neither practical nor necessary to erect a barrier, e.g. those parts of the course which are straight and are only used by the public to reach other parts of the course, may be indicated by the erection of the special type of Warning Notice (B). These notices should be displayed at least 30ft from the course. It is recommended that the limit of these areas should also be defined by a boundary tape.

2 PROHIBITION NOTICES

The following requirements regarding the display of Prohibition notices are applicable to all Road Racing events.

PROHIBITED AREA NOTICE (C) (29 × 20 inches.) Areas where the public are not permitted must be clearly defined by the display of an adequate number of "Prohibited Area" notices (B). Notices should be displayed within the prohibited area, facing the public.

12.6 DECLARATION – ADMISSION TICKETS, ARMBANDS AND PASSES

Subject to the provision of the Sunday Observance Act 1780, no person may be allowed to any part of the circuit without a suitable pass or ticket. All tickets and passes must bear the following wording shown below in full and if the wording appears on the reverse side then the words "For Conditions of Admission See Over" must be clearly printed on the face thereof. Where a ticket is cancelled by being torn in half, the full wording and, where applicable, the "For conditions of admission see over" must appear on each half. Where a charge is made for admission into special or "reserved" enclosures a ticket bearing the approved declaration must be issued in exchange for payment to enter these enclosures.

Declaration.

WARNING. MOTOR SPORT CAN BE DANGEROUS. Despite the organisers taking all reasonable precautions, unavoidable accidents can happen. Please comply with all instructions of marshals and notices and remain in permitted areas only. **THEY ARE CONCERNED WITH YOUR SAFETY.**

All vehicle passes must bear the same wording and comply with the above requirements.

12.7 DECLARATION ON THE OFFICIAL PROGRAMME

The declaration as outlined above should be printed in full on the outside front cover of all Official Programmes. Where this is not possible it must be printed in full in the programme and the words "For conditions of admission see inside" printed on the outside cover.

12.8 SIGNING ON

All riders, passengers, officials and assistants, press and team crew must sign a declaration on the relevant signing on form (available from the ACU).

1. Age Limits for Officials

All event Executive and Administrative Officials shall be 18 years of age or over.

2. Age Limits for Marshals
 1. All Assistant Officials whose function is to be carried out at the immediate track-side must be at least 16 years of age.
 2. All Assistant Officials who are under 18 years of age must have obtained parental agreement to carry out the duty and the signing-on signature must be countersigned by the person responsible for the official at the event.
 3. When using the services of officials under 18 years of age for any duties at any event special attention must be given to any risks which may be associated with the duty, and to the previous experience of the official.

SECTION 13 TECHNICAL SPECIFICATIONS

All machines must comply with the National Sporting Code Appendix B and general technical regulations. Any part of the motorcycle except the frame can be modified, altered or replaced.

13.1 CLASSES

1. SM4 – Junior Class up to 125cc two stroke single cylinder or up to 250cc four stroke single cylinder machines.
2. SM2 – 450 Class up to 450cc two or four stroke single or twin cylinder machines.
3. SM1 – Open Class 251 to 750cc two or four stroke single or twin cylinder machines.

13.2 NOISE CONTROL

The noise limit is 96 dB/A with no post race tolerance. The noise is measured according to the FIM Sound Control method.

13.3 NUMBER PLATES

Junior Class	White numbers on Green (RAL code 6002)
plates 450 Class	Black numbers on White (RAL code 9010)
plates	
Open Class	Black numbers on Yellow (RAL code 9005) plates

All numbers must comply with the numbers diagram printed elsewhere in this handbook.

13.4 PROTECTIVE CLOTHING

During practice and racing riders and passengers must wear the following clothing and footwear:

1. A complete all in one leather suit of at least 1.2mm in thickness on all parts of the suit, suits zipped together at the waist are not permitted. Non-leather material may be used if it meets with the following requirements.
2. The following characteristics of the material must be at least equivalent to 1.5mm of cowhide (not split leather). Fire retardant quality – Resistance to abrasion – Coefficient of friction against all types of asphalt – perspiration absorbing qualities – Medical test – non toxic and non allergenic – Fabric of a quality that does not melt. It must be non-flammable.
3. The following areas must be padded with at least a double layer of leather or enclosed plastic foam at least 8mm thick:
Shoulders, elbows, both sides of the torso and hip joint, the back of the torso, knees.
4. Competitors must wear complete undergarments if they use suits which are not lined. Suitable undergarments may be of the Nomex type, they may also be of silk or simply cotton. Synthetic materials which may melt and which could harm the riders skin in an accident are not allowed, neither for the suit nor for the undergarments.
5. Competitors footwear must be of leather or an approved substitute material and of a minimum height of 200mm to provide, with the suit, complete protection (i.e. no exposed areas).
6. Competitors must wear leather protective gloves.

7. The use of metallic material in any item of clothing or personal protection which regularly comes into contact with the track is prohibited (i.e. metal studs in knee sliders, boots etc.).
8. A back protector is compulsory.

13.5 HELMETS

Helmets bearing the current ACU gold stamp and in sound condition and properly fitted must be worn by all riders and passengers while practising and racing. Overseas riders may use helmets as approved by their own FMN.

13.6 IDENTIFICATION DISCS

While practising and racing, riders and passengers are required to wear an identification disc around the neck, attached by a material approved by the technical officer. Thin chains should be avoided. The disc must be permanently marked with the wearer's full name and date of birth. Identification discs shall be of a durable material, circular in shape, between 20mm and 25mm in diameter and having rounded edges with no sharp or ragged projections.

13.7 BODY JEWELLERY

It is recommended that any body piercing studs, ring etc. are removed.

Drag Race

Standing Regulations

SECTION 1 MEETINGS

1.1	Categories of Meetings	318
1.2	International	318
1.3	European Open	318
1.4	National	318
1.5	Open	318
1.6	Restricted	318
1.7	Eligibility of Foreign Riders in Open and Restricted Meetings	319
1.8	Practice Meetings and Test Days	319
1.9	Conditions for Drag Meetings	319

SECTION 2 LICENCES – COMPETITORS

2.1	General	319
2.2	Grades	319
2.3	Lapsed Licences	321
2.4	Capacity and Licence Restrictions for Junior Competitors	321

SECTION 3 LICENCES AND REGISTRATIONS – OFFICIALS

3.1	Qualifications and Conditions	321
3.2	Drag Officials who require a Licence	322
3.3	Grades for Clerk of the Course	322
3.4	Drag Officials who do not require a Licence	323

SECTION 4 BEHAVIOUR AT A MEETING

323

SECTION 5 SAFETY

5.1	Medical Services Minimum Requirements for Drag Meeting	324
5.2	Track Safety Precautions	325
5.3	Fire Extinguishers	325
5.4	Fire Extinguishers at Circuits	325
5.5	Warning and Prohibition Signs at Circuits	326
5.6	Declaration – Admission Tickets, Armbands and Passes	326
5.7	Declaration on the Official Programme	326
5.8	Signing On	326

SECTION 6 GENERAL SPECIFICATIONS OF MOTORCYCLES

6.1	Brakes	327
6.2	Tyres	327
6.3	Appearance	327
6.4	Capacity Restrictions	327
6.5	Drain Plugs	328
6.6	Fuel Lines	328
6.7	Fuel Tanks	328
6.8	Fuel Pumps	328
6.9	Fuels	328
6.10	Nitrous Oxide Injection Systems	328
6.11	Overflows	328
6.12	Handlebars and Control Levers	328
6.13	Throttle	329
6.14	Streamlining	329
6.15	Engine	329

6.16	Engine Restraints	329
6.17	Ignition	329
6.18	Computers	330
6.19	Gear Shift Systems	330
6.20	Footrests	330
6.21	Batteries	330
6.22	Numbers	330
6.23	Primary Transmission	330
6.24	Ground Clearance	330
6.25	Drive Chains and Guards	330
6.26	Superchargers/Turbochargers	330
6.27	Red Rear Lights	330

SECTION 7 PROTECTIVE CLOTHING

7.1	Protective Clothing	331
7.2	Body Jewellery	331
7.3	Helmets	331
7.4	Identification Discs	331

SECTION 8 9.50 BIKE

8.1	Carburettor	331
8.2	Clutch	331
8.3	Engine	331
8.4	Exhaust	331
8.5	Frame	332
8.6	Gearbox	332
8.7	Lights and Mirrors	332
8.8	Mudguards	332
8.9	Seat	332
8.10	Stands	332
8.11	Superchargers and Turbochargers	332
8.12	Fuel	332
8.13	Nitrous Oxide Injection	332
8.14	Suspension	332
8.15	Tyres	332
8.16	Wheels	332
8.17	Wheelie Bars	332

SECTION 9 SUPER STREET BIKE

9.1	Carburettor	332
9.2	Clutch	333
9.3	Engine	333
9.4	Exhaust	333
9.5	Frame	333
9.6	Gearbox	333
9.7	Computers	333
9.8	Lights and Mirrors	333
9.9	Mudguards	333
9.10	Seat	333
9.11	Stands	333
9.12	Superchargers and Turbochargers	333

9.13	Fuel	333
9.14	Nitrous Oxide Injection	333
9.15	Suspension	333
9.16	Tyres	333
9.17	Wheels	334
9.18	Wheelie Bars	334

SECTION 10 8.50 BIKE

10.1	Clutch and Primary Transmission	334
10.2	Engine	334
10.3	Exhaust	334
10.4	Frame	334
10.5	Mudguards	334
10.6	Seat	334
10.7	Superchargers/Turbochargers	334
10.8	Front Tyre	334
10.9	Wheels	334
10.10	Wheelbase	335

SECTION 11 PRO STOCK BIKE (PS)

11.1	Definition	335
11.2	Frames	335
11.3	Front Suspension	335
11.4	Controls	335
11.5	Body	335
11.6	Seats	335
11.7	Wheels	336
11.8	Tyres	336
11.9	Wheeliebar	336
11.10	Engine	336
11.11	Cylinder Head	336
11.12	Fuel Injection	336
11.13	Ignition	336
11.14	Fuel	336
11.15	Weight Breaks	336
11.16	Transmission	337
11.17	Engine/Weight Control	337

SECTION 12 COMPETITION BIKE (CB)

12.1	Clutch and Primary Transmission	337
12.2	Exhaust	337
12.3	Frame	337
12.4	Mudguards	337
12.5	Seat	337
12.6	Superchargers/Turbochargers	337
12.7	Front Tyre	338
12.8	Wheels	338
12.9	Wheelbase	338

SECTION 13 TOP FUEL (TF)

13.1	Designation	338
-------------	-------------	------------

13.2	Engine	338
13.3	Engine/Weight control	338
13.4	Body	338
13.5	Frame	338
13.6	Front suspension	338
13.7	Exhaust	339
13.8	Superchargers	339
13.9	Fuel shut off	339
13.1	Throttle linkage	339
0		
13.1	Wheels and Tyres	339
1		

SECTION 14 FUNNY BIKE (FB)

14.1	Designation	339
14.2	Class Requirements	339
14.3	Fuel Shut Off	339

SECTION 15 JUNIOR DRAG BIKE (JRB)

15.1	Engine	340
15.2	Suspension and Brakes	340
15.3	Frame	340
15.4	Wheels and Tyres	340
15.5	Body	340
15.6	Starting	340

SECTION 16 SUPER TWINS

16.1	Categories	340
16.2	Super Twin Top Fuel	340
16.3	Super Twin ET Bike	341
16.4	Super Twin Top Gas	342

SECTION 17 ET BIKE

343

SECTION 18 ACU/UK DRAG BIKE CHAMPIONSHIP

18.1	Classes	343
18.2	Eligibility	343
18.3	Specifications	344
18.4	Classification	344
18.5	Points	344
18.6	Ties	344
18.7	Awards	344
18.8	Publicity	344
18.9	Abandonment	345
18.10	Establishing Records	345
18.11	Qualifying	345
18.12	Choice of Lane	345
18.13	Elimination Ladder and Field Sizes	346
18.14	Alternates	346
18.15	Staging	346
18.16	First or Worst Procedure	346
18.17	Machine Weighing	346

18.18	Series Co-ordinator	346
18.19	Race Results	346

The National Sporting Code of the ACU and the Standing Regulations together with the Supplementary Regulations and any Final Instructions shall apply to all Drag Races held under an ACU Permit.

SECTION 1 MEETINGS

1.1 CATEGORIES OF MEETINGS

- International Meetings
- European Open Meetings
- National Meetings
- Open Meetings
- Restricted Meetings

Permits for all Drag Race competitions are issued by ACU Headquarters.

1.2 INTERNATIONAL

1. The Permit shall be issued by the ACU Headquarters for a meeting inscribed on the International Calendar of the FIM and having an FIM International Meeting Number (IMN).
2. An International meeting is open to Entrants and Riders of more than one nation who must hold an International Licence or a National Licence issued by the ACU valid for the particular meeting concerned.
3. All riders not holding a Licence issued by the ACU or SACU must carry proof of Insurance and a written Start Permission document issued by their FMN.

Note: This includes all riders holding a licence issued by the MCUI.

1.3 EUROPEAN OPEN

1. The permit shall be issued by ACU Headquarters for a meeting inscribed on the Calendar of the Fédération Internationale de Motocyclisme Europe (FIME) and having a European Meeting Number (EMN).
2. A European Open meeting is open to Entrants and Riders of more than one European nation who must hold the appropriate Competition Licence valid for the particular meeting concerned.
3. All riders not holding a Licence issued by the ACU or SACU must carry proof of Insurance and a written Start Permission document issued by their FMN.

Note: This includes all riders holding a licence issued by the MCUI.

1.4 NATIONAL

1. The Permit shall be issued by the ACU Headquarters.
2. A National meeting is open to Entrants and Riders who are the holders of a National or International Licence valid for the particular meeting concerned issued by any Federation.
3. All riders not holding a Licence issued by the ACU or SACU must carry proof of Insurance and a written Start Permission document issued by their FMN.

Note: This includes all riders holding a licence issued by the MCUI.

1.5 OpEN

1. An Open permit is issued by ACU Headquarters.
2. An Open meeting is open to Entrants and Riders who hold a valid ACU or SACU Licence for the meeting concerned.

1.6 RESTRICTED

1. A Restricted Permit is issued by ACU Headquarters.
2. A Restricted meeting is open to Entrants and Riders who hold a current ACU Licence valid for the meeting concerned.

3. The Supplementary Regulations issued for the event must specify all restrictions and requirements of eligibility.

1.7 ELIGIBILITY OF FOREIGN RIDERS IN OPEN AND RESTRICTED MEETINGS

1. The Supplementary Regulations issued for the event must specify the licence qualification and eligibility requirements of foreign riders.
2. All riders must have a current Licence and Start Permission from their own Federation valid for the event.

1.8 PRACTICE MEETINGS AND TEST DAYS

1. Permits for Practice Meetings and Test Days may be issued on application to the Permit Issuing Authority.
2. No such event may be held unless the appropriate Permit and Insurance has been issued.

1.9 CONDITIONS FOR DRAG MEETINGS

1. The ACU Road Race Committee must approve the Organiser.
2. The Venue must hold a current Track Licence or Track Certificate issued by the ACU Road Race Committee.
3. The ACU Secretariat must approve the Supplementary Regulations for the event and issue an ACU Permit prior to publication and circulation.
4. For all ACU Championships an ACU decal, supplied by the ACU Secretariat, must be displayed on each machine. Any rider not complying will be disqualified from the results of the race.
5. The Race Control must remain operative with all equipment in place until the end of the period provided for the lodging of a protest, and all officials and marshals must remain at the circuit and available to the Clerk of the Course and the Stewards during that period.
6. There will be a minimum turn-around time of 30 minutes for all classes except for Pro-stock and Funny Bike where the turn-around time will be 45 minutes and for Top Fuel where the turn-around time will be 60 minutes. In all cases these turn-around times are subject to track conditions permitting.

SECTION 2 LICENCES – COMPETITORS

2.1 GENERAL

1. To participate in Drag Race events a Licence issued by the ACU is required. Residents in Scotland apply to the Scottish ACU.
2. A Licence can be upgraded at any time during the year, providing the correct criteria have been complied with.
3. The parent or legal guardian must accompany all competitors under 18 years of age to every meeting. This person must attend at signing-on and be present throughout the meeting.
4. A Clubman Licence will be issued to all new riders to include a record form, which, on completion of requirements set out below, will be completed by the Clerk of the Course at a RWYB meeting or an ACU recognised event.
5. Any rider competing on a new bike to him/her must first complete single runs to the satisfaction of the Clerk of the Course.

2.2 GRADES

1. Clubman

- Entry level for first time applicants for Category 1 or Category 2 machines.
- Category 1
8.50
9.50

ET Bike

Super Twin Top Gas (STG)

Super Twin RET Bracket (SET)

Clubman Licence holders can compete on a Category machine 1 once they have completed the following requirements to the satisfaction of an ACU Clerk of the Course.

- Be conversant with the start & race procedure;
- Perform a tyre burnout and start correctly;
- Complete a satisfactory Launch;
- Make a half pass (1/8 mile) under power to the satisfaction of the Clerk of the Course;
- Make a full run (1/4 mile) representative of the performance expected within the category. All tasks must be made as single runs during qualifying sessions at an ACU recognised drag race meeting or under the control of an ACU licensed National or International Drag Race Clerk of the Course at RWYB meetings.

The Clerk of the Course may request the rider to repeat tasks until they are satisfied a satisfactorily safe standard has been achieved, which may take more than one race meeting and is at the sole discretion of the Clerk of the Course.

The 1/4 mile pass will count towards qualifying at an ACU recognised

event. Category 2 – Riders 18 yrs of age and over

Clubman licence holders are not eligible to compete on Category 2 machines. They are permitted to ride a category 2 machine to complete the tasks required to upgrade to a National licence as detailed below.

Super Twin Top Fuel (STF)

Super Street Bike

Competition Bike

Pro Stock

Bike Funny

Bike Top Fuel

Bike

2. **National**

Clubman Licence holders who have completed the following tasks to the satisfaction of an ACU National or International Clerk of the Course and whose record card has been endorsed by the Clerk of the Course for each task completed may apply to upgrade to National.

- Be conversant with the start & race procedure;
- Perform a tyre burnout and start correctly;
- Complete a satisfactory Launch;
- Make a half pass (1/8 mile) under power to the satisfaction of the Clerk of the Course;
- Make a full run (1/4 mile) representative of the performance expected within the category. All tasks must be made as single runs during qualifying sessions at an ACU recognised drag race meeting or under the control of an ACU licensed National or International Drag Race Clerk of the Course at RWYB meetings.

The Clerk of the Course may request the rider to repeat tasks until they are satisfied a satisfactorily safe standard has been achieved, which may take more than one race meeting and is at the sole discretion of the Clerk of the Course.

National licence holders are eligible to compete on Category 1 or Category 2 machines.

National licence holders who have competed at 3 ACU permitted events may apply for Start Permission to compete abroad.

3. **International**

National Licence holders who have held their National Licence for 12 months may apply for an FIM Non-Championship Licence.

A medical examination is required.

4. **International Championship**

National Licence holders who have held their National Licence for 12 months may apply for a FIME or FIM Championship Licence as described in the appropriate Sporting Code. A medical examination is required.

2.3 **LAPSED LICENCES**

Clubman or National Licence holders who have allowed their Licences to lapse for more than 5 years will be re-issued with a Clubman Licence and will be required to complete the criteria set out above to retain the Clubman Licence or upgrade to the National Licence.

2.4 **CAPACITY AND LICENCE RESTRICTIONS FOR JUNIOR COMPETITORS**

For each category the table indicates the minimum licence requirements for their specified ages and machines.

Riders must be a minimum of 8 years of age.

To be eligible to enter Junior Pro Bike, a rider must be at least 14 years of age and must have competed in Junior Bike Mod for a minimum of five ACU Junior Drag Bike meetings.

Class	Engine Restrictions	Min Age	Max Age	Min ET
Junior Bike	50cc automatic or 125cc 4 Stroke	8	11*	12.90
Junior Mod Bike	125cc 2 Stroke or 250cc 4 Stroke	11	17*	8.90
Junior Pro Bike	250cc 2 Stroke or 500cc 4 Stroke	14	17*	7.90

***A rider may compete in a class until the end of the calendar year in which he reaches the maximum age for that class.**

Junior riders will compete over a maximum distance of 1/8 mile, and will be run on an ET dial in basis.

Important Notice

If a participant is under 18 years of age he/she must be accompanied to every meeting by their Parent or Legal Guardian. The Parent or Legal Guardian must attend signing on with the competitor and be available for the duration of the meeting.

Penalties

A rider recording an ET of 0.2 seconds or quicker below their class minimum will receive one warning.

A repetition of the offence at the same event will result in disqualification from the remainder of the event.

However, a rider recording a time of 0.4 seconds or quicker below their class ET or exceeding 85mph will be immediately disqualified from the event.

The above penalties will be imposed regardless of whether the infraction occurs during qualifying or eliminations.

FIME Junior Drag Cup. Junior riders wishing to compete in the FIME Junior Drag Cup, or any other Drag race abroad, will be assessed individually based on their own proven ability at ACU permitted races.

SECTION 3 LICENCES AND REGISTRATIONS – OFFICIALS

3.1 **QUALIFICATIONS AND CONDITIONS**

Drag Officials are divided into two categories: Those that are Licensed and those that are Registered. Fees may be charged for attendance at Seminars. Licences: Senior Drag Officials are required to hold an ACU Licence of the appropriate Grade for the performance of their duties.

Registration: A Register is maintained of Officials not required to hold a Licence.

3.2 DRAG OFFICIALS WHO REQUIRE A LICENCE

	See Note Below	Attendance at Seminar/Training Session
Clerk of the Course	1	Every third year maximum
Chief Steward	2	Every third year maximum
Chief Technical Officer	3	Every third year maximum
Sound Inspector		Required for First Issue only
Measurer	4	Required for First Issue only
Timekeeper	5	Equipment and operators check

All the above licences are valid for 3 years.

Clubs and Centres shall only nominate candidates whose aptitude and integrity for the position they can fully justify. Official ACU approval and the issue of a Licence is only after the candidates have proved to be competent according to the special requirements for each discipline. The respective Committees and Panels organise Seminars that are compulsory for certain Officials.

3.3 GRADES FOR CLERK OF THE COURSE

1. **Probationary.** Any club may nominate a Probationary Clerk of the Course. Such a Registered Official may only act as an Assistant Clerk of the Course at a Closed to Club event.
2. **National Grade D.** A Clerk of the Course who may officiate at any Closed to Club, National Restricted or National event for Hill Climb, Drag or Sprint. May officiate as a Deputy to a National Grade E Clerk of the Course.
3. **National Grade E.** A Clerk of the Course who may officiate at any event held under an ACU Permit for Hill Climb, Drag or Sprint. May officiate as a Deputy or Assistant to an FIM International Clerk of the Course for Hill Climb, Drag or Sprint. To upgrade from a National D to a National E a licence holder must officiate as a National D Clerk of the Course at 5 events. He must act as a Deputy to a National E Clerk of the Course at 5 events and be recommended by the Clerk of the Course at each. In addition members of the Road Race, Drag and Sprint Committee may be appointed to observe him. A club must nominate him as being required to take charge of a specific future event.

Note 1 Clerk of the Course

Age Limits: Regardless of age or type of licence held Clerks of the Course of all grades may not officiate beyond the end of the season in which they attain their 70th birthday.

Note 2 Chief Steward

There is only one grade of Steward's Licence for all Road Race disciplines.

Age Limits: Stewards may not normally officiate beyond the end of the season in which they attain their 70th birthday.

The Road Race, Drag and Sprint Committee will review Stewards who reach the age of 70 for appointments on an annual basis.

Note 3 Chief Technical Officer

The Chief Technical Officer will be licensed by the Technical Panel to be in charge of the Technical Control at an event.

The Technical Panel may restrict the disciplines of licence holders.

Note 4 Measurer

The Measurer is required for ACU National Championships and National events. The Licence is issued by the Technical Panel and may be restricted by discipline.

Note 5 Timekeepers

Will be required to pay for their Licence.

Licence Fees: All licences (exception Timekeepers licences) will be issued, free of charge, for a period of three years. A fee will be charged for attendance at all Seminars organised by the Road Race Drag and Sprint Committee or the relevant Panel.

3.4 DRAG OFFICIALS WHO DO NOT REQUIRE A LICENCE

Registration of the following officials and marshals will be renewed annually and they will receive an appropriate form of identification from the ACU.

See Note Below Attendance at Seminar/Training Session

Incident Officer	1	Refer to Note 1
Secretary of the Meeting	2 and 4	Will receive Training at meetings and if required at Regional or ACU HQ Seminars.
Technical Official		Will receive training via the Chief Technical Officer at meetings. May attend Regional Training Seminars
Club Stewards	3	May attend Regional or ACU HQ Seminars for information purposes
Chief Marshal		May receive training at ACU HQ or Regional Training Days
Marshal		May receive training at Regional Training days and at days and at meetings via the Chief Marshal
Medical Officer		None required

Note 1 Incident Officer

Will collate all information and documentation, and prepare reports relating to serious accidents and to all incidents involving Officials or Spectators.

For 2019 it is recommended that the Incident Officer is at least a Probationary Clerk of the Course or has attended an Incident Officer Seminar.

For 2020 and onwards the Incident Officer will be required to hold at least a Probationary Clerk of the Course licence or have attended an Incident Officer Seminar.

Note 2 Secretary of the Meeting

Will be responsible for all administration connected with the organisation of a meeting.

Note 3 Club Stewards

Will together with the Chief Steward form the judicial authority over the running of the meeting.

Note 4 Secretary of the Meeting Registration

Currently there is no requirement for these officials to be registered for Road Race Disciplines.

SECTION 4 BEHAVIOUR AT A MEETING

4.1 ANY INFRINGEMENT OF THESE RULES WILL BE PENALISED

- Riders who fall from their machine are not permitted to continue in the meeting until passed fit by the Medical Personnel and his machine re-inspected by technical control. In the event of a serious accident organisers may impound any machines, equipment or clothing of riders involved in the accident.
- Riders must not ride or push their motorcycles in the opposite direction of the circuit, unless doing so under the direction of an Official.
- The carrying of on board cameras is only permitted with the prior approval, in writing of the Clerk of the Course. The installation of the camera must be approved by the Chief Technical Officer.
- Stopping on the track during a run is forbidden except for machine failure.
- The spinning of rear wheels (burn-outs) is strictly forbidden on the track, with the exception of the Start Area. Breach of this rule will result in a penalty of disqualification.

6. All competitors finishing an event must submit the machine for final examination if required. The organisers may retain that machine for a reasonable period to allow for that examination.
7. Any competitor who in any ACU or MCRCB Permitted Event participates on a machine for which he is not eligible through age or licence restrictions will be penalised by a fine of £500.00 and a suspension for one year from the date of the hearing.

SECTION 5 SAFETY

5.1 MEDICAL SERVICES MINIMUM REQUIREMENTS FOR DRAG MEETING

	PERSONNEL			VEHICLES		
	Doctors MO	Paramedic(s) PM	First Aid personnel	Ambulance(s)	Fast Intervention Vehicle	Special Notes
Drag Race	1 MO or 1 Paramedic		2	1		

The following applies to all events run under this code.

1. **Medical Officer (MO) – Doctor** A medical practitioner (doctor) fully registered with the General Medical Council (GMC), and holding appropriate personal medical malpractice insurance cover (excludes NHS Crown Indemnity).
2. **Paramedic (PM)** A State Registered Paramedic with the HPC (Health Professions Council). Paramedics must have appropriate personal medical malpractice insurance cover.
3. **Ambulance** A vehicle registered as an ambulance with the DVLA (Driver and Vehicle Licensing Agency) and registered with CQC if appropriate. An ambulance must have an appropriately qualified driver to transport a casualty under blue lights. It must be equipped with the FIM minimum equipment regulations for a type C vehicle; that is:
 - Medical: A stretcher (preferably standardised), oxygen supply, apparatus to immobilise limbs and vertebral column. First aid medicaments and materials.
 - Technical: Radio communication. Visible and audible signals.
 - Staffing: An ambulance must be staffed by two First Aid Personnel (who can be the two minimum First Aid Personnel).
 An ambulance may act as a Medical Centre BUT if so it must be a vehicle in addition to the minimum ambulance requirement.
4. **First Aid Personnel** A person holding a current certificate of First Aid competency. (Where an event open to the public event organisers should ensure that all First Aid personnel are insured against malpractice for the event concerned).

Special Notes

The minimum medical requirements specific for this discipline also apply to associated Test Days.

5. **Medical Examination** At any time during a meeting the Clerk of the Course may require a competitor to undergo a medical examination to determine his fitness to ride. The decision of the medical officer is final without right of appeal.
6. **Concussion/suspected concussion** If a competitor is involved in an incident which results in him being diagnosed by the Medical Officer/Paramedic as suffering from concussion/suspected concussion, the rider is not permitted to participate any further in that event.

Organisers are to notify ACU Head Office as soon as possible of any concussion/suspected concussion injuries and then will subsequently:

 - a) Place the rider on the ACU Stop List
 - b) Inform Organisers of forthcoming events that the Rider has suffered a concussion/ suspected concussion injury and is therefore placed on the ACU Stop List
 - c) Inform the Rider that he needs to see a Doctor and obtain a letter/doctor's certificate which confirms he is fit to resume competitive racing/participate in a practice/test session.

The recovery time for anyone diagnosed with concussion/suspected concussion is as follows:

- a) Over 20 years: Excluded immediately and suspended for a period of nine days.
- b) 16–19 years: Excluded immediately and suspended for a period of twelve days.
- c) 15 and under: Excluded immediately and suspended for a period of twenty three days. The rider is not permitted to ride during the obligatory suspended periods outlined above and then only once he is in possession of a doctor's certificate/letter after the suspended period has expired.
A rider may be signed off to ride by the CMO at an event once he has observed the obligatory suspended period outlined above.
If a competitor has been injured on a Saturday and is suffering from concussion/suspected concussion, and the Organiser is aware that the rider was intending to ride or is scheduled to ride somewhere else the next day, the Organiser will inform the Organiser of the event being held the next day so they are aware of the rider's injuries and as such he is prevented from participating in that event.

5.2 TRACK SAFETY PRECAUTIONS

1. The safety precautions of circuits will be as laid down for each permanent course licence or temporary course certificate following an inspection of the course.
2. It should be generally realised that the organisers of speed events have a legal responsibility to the general public and therefore it is the duty of these organisers to ensure that all reasonable precautions are taken to protect the public.
3. Whilst organising clubs are insured under the Promoters Third Party Policy in respect of their legal liability, it is a condition of the policy that the promoters of an event must comply strictly with the National Sporting Code and any additional requirements as may be specified by the Permanent Course Licence or Temporary Course Certificate. Clubs failing to do so stand in grave danger of any claims being repudiated to the club by the insurers under the terms of the policy covering legal liability.
4. The safety precautions to be adopted are provided with the Permanent Course Licence or Temporary Course Certificate for the particular course but the following general requirements must be observed.
5. The attention of organisers is drawn to the provision of the NSC which stipulates that no alteration of the requirements contained in the Permanent Course Licence or Temporary Course Certificate shall be made without the prior approval, in writing, of the ACU.
6. It is recognised that circumstances may arise in which it is necessary to make certain alterations to the course on the day of the meeting but any such alterations must be approved by the Stewards of the Meeting and details given in their report to the authority granting the permit.

5.3 FIRE EXTINGUISHERS

Each working vehicle in the Paddock must have a 2kg (minimum) dry powder fire extinguisher available for immediate use. This extinguisher must show the date of the last annual inspection. Non-compliance with this regulation will incur a penalty imposed by the Clerk of the Course.

5.4 FIRE EXTINGUISHERS AT CIRCUITS

At all race and speed events, there must be a valid certificate, issued annually immediately prior to the start of each season's racing by the manufacturer or his agent, to the effect that all fire extinguishers are in effective working order. This certificate must be available for inspection by the Stewards.

All fire posts must be clearly marked. In addition to the fire equipment at each post there must be:

1. Fire extinguishers in the paddock and assembly area.
2. At least two fire extinguishers in the Technical Control Area.
3. Fire extinguishers in every medical room/centre.

5.5 WARNING AND PROHIBITION SIGNS AT CIRCUITS

For full details regarding Warning Notices and Prohibition Notices please refer to the Safety Precautions section of this Handbook.

1 WARNING NOTICES

The following requirements regarding the display of Warning notices are applicable to all Road Racing events.

1. WARNING NOTICE (A) (29 × 20 inches.) Warning notices as detailed below must be displayed on each side of every entrance to the course, including the entrance to car parks and paddock. These notices must be prominently displayed where they can be easily read by the public before any admission charge is paid, or where no admission charge is made before entry is gained into the circuit.
Where it is not possible to define the limits of the site and to control admission of the public (e.g. War Department and heath land) warning notices must be profusely displayed around the course and also in the car parks.
2. WARNING NOTICE (B) (20 × 15 inches.) Those parts of the course to which the public maybe admitted and where it is neither practical nor necessary to erect a barrier, e.g. those parts of the course which are straight and are only used by the public to reach other parts of the course, may be indicated by the erection of the special type of Warning Notice (B). These notices should be displayed at least 30ft. from the course. It is recommended that the limit of these areas should also be defined by a boundary tape.

2 PROHIBITION NOTICES

The following requirements regarding the display of Prohibition notices are applicable to all Road Racing events.

PROHIBITED AREA NOTICE (C) (29 × 20 inches.) Areas where the public are not permitted must be clearly defined by the display of an adequate number of "Prohibited Area" notices (B). Notices should be displayed within the prohibited area, facing the public.

5.6 DECLARATION – ADMISSION TICKETS, ARMBANDS AND PASSES

Subject to the provision of the Sunday Observance Act 1780, no person may be allowed to any part of the circuit without a suitable pass or ticket. All tickets and passes must bear the following wording shown below in full and if the wording appears on the reverse side then the words "For Conditions of Admission See Over" must be clearly printed on the face thereof. Where a ticket is cancelled by being torn in half, the full wording and, where applicable, the "For conditions of admission see over" must appear on each half. Where a charge is made for admission into special or "reserved" enclosures a ticket bearing the approved declaration must be issued in exchange for payment to enter these enclosures.

Declaration.

WARNING. MOTOR SPORT CAN BE DANGEROUS. Despite the organisers taking all reasonable precautions, unavoidable accidents can happen. Please comply with all instructions of marshals and notices and remain in permitted areas only. THEY ARE CONCERNED WITH YOUR SAFETY.

All vehicle passes must bear the same wording and comply with the above requirements.

5.7 DECLARATION ON THE OFFICIAL PROGRAMME

The declaration as outlined above should be printed in full on the outside front cover of all Official Programmes. Where this is not possible it must be printed in full in the programme and the words "For conditions of admission see inside" printed on the outside cover.

5.8 SIGNING ON

All riders, passengers, officials and assistants, press and team crew must sign a declaration on the relevant signing on form (available from the ACU).

1. Age Limits for Officials
All event Executive and Administrative Officials shall be 18 years of age or over.
2. Age Limits for Marshals
 1. All Assistant Officials whose function is to be carried out at the immediate track-side must be at least 16 years of age.
 2. All Assistant Officials who are under 18 years of age must have obtained parental agreement to carry out the duty and the signing-on signature must be countersigned by the person responsible for the official at the event.
 3. When using the services of officials under 18 years of age for any duties at any event special attention must be given to any risks which may be associated with the duty, and to the previous experience of the official.

SECTION 6 GENERAL SPECIFICATIONS OF MOTORCYCLES

Motorcycles must comply with these general conditions unless they are amended in the specific class conditions.

6.1 BRAKES

1. All machines must be equipped with at least one efficient brake per wheel, operating independently, and acting directly on the wheel.
2. Hydraulic brakes may be fitted to any wheel, provided that the cylinders and lines are adequately protected from accidental damage. The hydraulic fluid reservoir must be mounted in such a position as to allow easy inspection of the fluid level.
3. All disc brakes must be of the double calliper pattern, e.g. having brake pads on each side of the disc. Must be able to operate from normal riding position i.e. both hands on handlebars and feet on footrests.
4. Minimum disc sizes:
Front: 250mm × 4.5mm single
200mm × 4.5mm dual
220mm × 4.5mm dual (for Nitromethane powered machines)
Rear: 250mm × 4.5mm if single front disc fitted
200mm × 4.5mm if dual front discs fitted
250mm × 4.5mm (for Nitromethane powered machines)

6.2 TYRES

1. The minimum cross section of tyre allowed for any class is 50mm.
2. Dust caps must be fitted to all tyre valves.
3. For street tyre classes readily available street tyres only, 1mm minimum tread depth, slicks, hand cut slicks, and tyres marked "Not for Highway Use" not allowed.
4. Any tyre which, in the opinion of the Technical Official, bears any signs of having sidewall markings or lettering tampered with will be grounds for immediate disqualification of the rider from the event.

6.3 APPEARANCE

All machines must be of presentable appearance at all times. Entries may be refused where appearance is not considered to be up to the general standards of competition.

6.4 CAPACITY RESTRICTIONS

Where the individual class regulations allow, superchargers and turbochargers are allowed up to 2400cc, normally aspirated engines are allowed up to 3300cc.

6.5 DRAIN pLUGS

All drain plugs securing any liquid must be so fitted as to prevent any leakage, and positively locked against loosening, with wire.

6.6 FUEL LINES

Must be securely fitted at all joints and a quick action fuel tap must be within easy reach of the rider. Where nitromethane fuel is used in any percentage, a lanyard is mandatory to operate a spring loaded fuel shut off valve which must completely cut off the fuel supply to the engine.

6.7 FUEL TANKS

All fuel tanks must be securely fitted to the machine and incorporate securely fitting filler caps. Tanks must be robustly constructed.

6.8 FUEL pUMpS

Any make of fuel pump may be fitted. If electrically operated, the pump must be connected to the ignition switch so that they are switched off with the ignition.

6.9 FUELS

For petrol-burning classes, the dielectric constant as per DC meter may be no greater than 4, and Propylene Oxide is prohibited. Octane boosters are permitted. For non petrol-burning classes, hydrazine and propylene oxide are not permitted, otherwise there is no limitation to the types of fuel allowed. Competitors should check the class regulations for any specific restrictions.

Unless otherwise specified for any series or championship, leaded or unleaded pump or racing fuel will be permitted. The use of E85 fuel is permitted but fuel tank should be clearly marked with the words 'Bio Fuel'.

6.10 NITROUS OXIDE INJECTION SYSTEMS

1. Only gas storage cylinder certified for use at the working pressure of the system may be used (this also applies to any machine with a pressurised gas fuel system).
2. All receiving cylinders should have rupture discs or safety valve to prevent over pressurisation.
3. The bottle to solenoid supply pipe should be of a high quality braided steel hose attached to the frame at regular intervals.
4. For any machine running Nitrous Oxide, the system must remain inoperable until the throttle is fully open.
5. Any other switches must be wired through the throttle switch. The engine must be able to be cranked over without the ignition system operable to enable purging of any gas from the combustion chambers.
6. A separately operated ignition arming switch must be fitted.

6.11 OVERFLOWS

All breathers must terminate in a catch can/tank of 550ml minimum capacity or vent into the exhaust/ induction system. Cans should be of a two chamber design or with intake isolated from outlet to ensure oil cannot exit directly from the inlet.

6.12 HANDLEBARS AND CONTROL LEVERS

1. Any type or make of handlebar may be fitted at the owner's discretion.
2. It is compulsory to fit lock stops to ensure a minimum clearance of 25mm between the handlebars and any other part of the machine, to prevent trapping of the rider's hands.
3. The minimum angle of rotation either side of centre line or mid point is 20 degrees.
4. Handlebar grips, if fitted, must be securely attached.
5. All control levers (clutch, brake etc.) must be in principle 'ball ended', diameter of ball end to be

12.5mm minimum. The ball end may be flattened to a minimum thickness of 12.5mm, but all edges must be rounded. Ball ends must be permanently fixed and form an integral part of the lever.

6.13 THROTTLE

1. All motorcycles must have the throttle controlled by a hand operated twistgrip, incorporating a positive acting spring attached directly to the carburettor throttle arm.
2. The throttle must close automatically upon releasing the twistgrip.
3. For any motorcycle running nitromethane fuel, it is mandatory to have a positive return cable as well as a return spring, i.e. a push-pull twistgrip.
4. Any machine running Nitrous Oxide, the system must remain inoperable until the throttle is fully open.
5. Any other switches must be wired through the throttle switch.
6. For nitro fuelled bikes with slider clutches a throttle locking device that will positively lock the butterfly to barrel valve linkage is mandatory.
 1. It is recommended that this device is located at the butterfly end of the linkage, however a drilled throttle twist grip with locking pin is acceptable.
 2. This device is to be operated when the machine is being pushed back with the engine running.
 3. The locking device must be suitably flagged to clearly indicate when it is in use.

6.14 STREAMLINING

1. There must be clearance of at least 20mm between the streamlining and the extremities of the handlebars or steering device, including any attachment thereto, whatever the position of the handlebars.
2. It must not be possible for the front wheel to make contact with the streamlining whatever the position of the handlebars.
3. The streamlining must be constructed of metal or other suitable material, and fitted to allow complete liberty of movement of the rider, both when riding and when getting on and off the machine, without the streamlining or any part of it having to be displaced.
4. The screen, if fitted, must be constructed of a shatterproof material.

6.15 ENGINE

OEM car and motorcycle engines allowed. Non OEM based engines allowed at the sole discretion of the ACU Technical Committee following submission of drawings showing cylinder bore and stud position.

6.16 ENGINE RESTRAINTS

V-Twin motors running injected nitromethane must utilise cylinder head restraint. Restraints meeting SFI 46.1 are highly recommended.

6.17 IGNITION

1. Any type or make of ignition system may be fitted.
2. A positive acting cut out switch must be fitted, and attached to the top fork yoke or handlebars. Ignition KILL buttons are not acceptable.
3. For 8.50, 9.50, ET, Super Street, Pro Stock, Competition Bike, Funny Bike, and Top Fuel (where applicable), all machines except Nitromethane fuelled machines must have a positive KILL switch attached to the rider by lanyard that shuts down ALL electrical systems on the machine. The lanyard/KILL switch must be able to work when pulled in any direction.
4. A lanyard assembly must be of sufficient strength for purpose. Any lanyard assembly that, in the opinion of the technical team, is not fit for purpose is grounds for disqualification.

6.18 COMPUTERS

Can be used for information gathering only. Throttle operation, shifting, clutch activation, control of fuel injection metering etc. are to be solely under the control of the rider or preset prior to any run.

6.19 GEAR SHIFT SYSTEMS

1. Where individual class rules allow, timed gear shift allowed as long as preset prior to run. Automatic gear shifting prohibited unless OEM of engine used. RPM gear shifting strictly prohibited.
2. Where the gear shift is air and/or electrically assisted, all wiring and switches for this system must be separate from the main wiring harness, and must be readily identifiable, traceable and accessible for inspection by the Technical Official.
3. Except where clearly part of an ignition kill device, any part of the wiring in the gear shift system which, in the opinion of the Technical Officer, passes through, or is connected to a closed control box or unit of any type, will be grounds for disqualification.
4. Suspension travel and ride height sensing is not permitted.

6.20 FOOTRESTS

Unless original equipment is used the footrests should be of minimum 19mm diameter and 75mm long and ball ended.

6.21 BATTERIES

May be located at the owner's discretion, providing that the mounting is of sound construction.

6.22 NUMBERS

Competitors should display their class and vehicle numbers to the rear and each side of the motorcycle, in numbers and letters at least 75mm high.

6.23 PRIMARY TRANSMISSION

1. If the clutch and/or primary transmission is exposed it must be fitted with a guard as a safety measure to protect the rider even as a result of breakage.
2. The guard must be conceived in such a manner as to minimise the risk of a rider coming into accidental contact with these transmission parts and designed to protect the rider from injury.
3. Outboard mounted clutches must have a cover of at least 3mm aluminium or 1mm steel.
4. Any suitable make or type of drive chain/belt may be installed.

6.24 GROUND CLEARANCE

Where no particular class rules apply. Immediately after a run machines must have a minimum ground clearance of 50mm with the rider sitting on the machine in the normal riding position with their feet off the ground. Failure to comply will result in disqualification of the run.

6.25 DRIVE CHAINS AND GUARDS

Any suitable make or type of chain may be used, but must be adequately guarded. Stock chain guards, or guards manufactured from 3mm Dural (or equivalent strength alternative) must be fitted to prevent the chain contacting the rider as a result of breakage.

6.26 SUPERCHARGERS/TURBOCHARGERS

Considered the same device.

6.27 RED REAR LIGHTS

Machines must be equipped with a non-pulsating rear-facing red light. If the Clerk of the Course deems it necessary these red lights must be switched on.

SECTION 7 PROTECTIVE CLOTHING

7.1 PROTECTIVE CLOTHING

The rider must wear his protective clothing to Technical Control to demonstrate good fit.

1. Bulky hard objects such as tools etc. are NOT to be carried in pockets or on the person.
2. During practice and racing, riders and passengers must wear the following clothing and footwear:
3. Competitors must wear a complete leather suit of at least 1.2mm in thickness (on all parts of the suit), two piece suits that zip together at the waist are acceptable. Each part of the zip should be securely attached to the jacket or the trousers respectively and the suit must zip together over at least 75% of the waist band.
4. Non-leather material may be used if it meets with the requirements laid down by ACU Road Racing Standing Regulations.
5. Competitors' footwear must be of leather (i.e. outer hide) or an approved substitute material and of a minimum height of 200mm to provide, with the suit, complete protection. No areas of skin to be left exposed between the leg of the suit and the top of the boot.
6. Competitors must wear leather (or an approved substitute material) protective gloves to provide, with the suit, complete protection. No areas of skin to be left exposed between the wrist of the suit and the wrist of the glove.
7. Long hair and beards should be contained within the helmet or clothing.

7.2 BODY JEWELLERY

It is recommended that any body piercing studs, ring etc. are removed.

7.3 HELMETS

Helmets bearing the current ACU gold stamp and in sound condition and properly fitted must be worn by all riders and passengers while practicing and racing. Overseas riders may use helmets as approved by their own FMN.

7.4 IDENTIFICATION DISCS

While practising and racing, riders and passengers are required to wear an identification disc around the neck, attached by a material approved by the technical officer. Thin chains should be avoided. The disc must be permanently marked with the wearer's full name and date of birth. Identification discs shall be of a durable material, circular in shape, between 20mm and 25mm in diameter and having edges with no sharp or ragged projections.

SECTION 8 9.50 BIKE

A petrol-burning street tyred class with a 9.50 index.

8.1 CARBURETTOR

Any type of carburettor or fuel injection may be used.

8.2 CLUTCH

Any type, make or pattern of clutch assembly may be installed. All clutches must be fully enclosed.

8.3 ENGINE

May be of any type with any modifications. Only one engine allowed.

8.4 EXHAUST

Any type of exhaust allowed. No flexible pipe is allowed. Open exhaust permitted.

8.5 FRAME

Steering head geometry, trail and wheelbase may be altered to improve the stability of the machine, provided that all modifications are undertaken to a safe and professional standard. Maximum wheelbase permitted is 1730mm, measured with the rear wheel in the most extended position allowed by the swinging arm.

8.6 GEARBOX

Any make or type may be fitted.

8.7 LIGHTS AND MIRRORS

1. Lights need not be operational, but must be of stock appearance, lenses must be taped over.
2. Mirrors should be removed or taped over.

8.8 MUDGUARDS

Must be fitted to comply with the Road Traffic Act.

8.9 SEAT

Any type allowed, must be securely fitted to machine. Any padding used must be securely attached to the seat.

8.10 STANDS

Must be wired up or removed.

8.11 SUPERCHARGERS AND TURBOCHARGERS

Allowed.

8.12 FUEL

Generally available pump or racing petroleum is allowed. The use of E85 Fuel is permitted but the words 'Bio Fuel' must be clearly displayed on the tank.

8.13 NITROUS OXIDE INJECTION

Allowed.

8.14 SUSPENSION

Any type allowed, but if fitted must be operational. Rear struts allowed.

8.15 TYRES

See General Technical Regulations.

8.16 WHEELS

Any type or size permitted, as long as they comply with the Road Traffic Act. It is highly recommended that rear rim width should not exceed tyre width.

8.17 WHEELIE BARS

Not permitted.

SECTION 9 SUPER STREET BIKE

A petrol-burning street tyred class.

9.1 CARBURETTOR

Any type of carburettor or fuel injection may be used.

9.2 CLUTCH

Any type, make or pattern of clutch assembly may be installed. All clutches must be fully enclosed.

9.3 ENGINE

May be of any type with any modifications. Only one engine allowed.

9.4 EXHAUST

Any type of exhaust allowed. No flexible pipe is allowed. Open exhaust permitted.

9.5 FRAME

Steering head geometry, trail and wheelbase may be altered to improve the stability of the machine, provided that all modifications are undertaken to a safe and professional standard. Maximum wheelbase permitted is 1730mm, measured with the rear wheel in the most extended position allowed by the swinging arm.

9.6 GEARBOX

Any make or type may be fitted.

9.7 COMpUTERS

Closed loop systems with proactive functionality allowed.

9.8 LIGHTS AND MIRRORS

1. Lights need not be operational, but must be of stock appearance, lenses must be taped over.
2. Mirrors should be removed or taped over.

9.9 MUDGUARDS

Must be fitted to comply with the Road Traffic Act.

9.10 SEAT

Any type allowed, must be securely fitted to machine. Any padding used must be securely attached to the seat.

9.11 STANDS

Must be wired up or removed.

9.12 SUPERCHARGERS AND TURBOCHARGERS

Allowed.

9.13 FUEL

Generally available pump or racing petroleum is allowed. The use of E85 Fuel is permitted but the words 'Bio Fuel' must be clearly displayed on the tank.

9.14 NITROUS OXIDE INJECTION

Allowed.

9.15 SUSPENSION

Any type allowed, but if fitted must be operational. Rear struts allowed.

9.16 TYRES

See General Technical Regulations.

9.17 WHEELS

Any type or size permitted, as long as they comply with the Road Traffic Act. It is highly recommended that rear rim width should not exceed tyre width.

9.18 WHEELIE BARS

Not permitted.

SECTION 10 8.50 BIKE

A class for machines complying with the general and safety regulations.

Standing Regulations as per Competition Bike.

10.1 CLUTCH AND PRIMARY TRANSMISSION

Any type, make or pattern of clutch assembly and/or drive chain/belt may be installed.

10.2 ENGINE

Aftermarket cases must have the same number of cylinder studs as OEM motorcycle manufacture and located within 2mm of stock position, twin or v8 engines excepted.

10.3 EXHAUST

Any make or type of exhaust system allowed. No flexible pipe allowed.

10.4 FRAME

1. Frame may be original factory equipment, altered or modified at the owner's discretion, or of tubular type frame construction. All butt welds must have visible reinforcement, and no grinding or filling of welds is permitted.

10.5 MUDGUARDS

1. Are not compulsory, but if fitted must be constructed of material with no sharp edges, and must be securely fitted to the machine.
2. If a stock front mudguard is removed, and an aftermarket item used, a fork brace of adequate dimensions must be fitted on machines weighing 205kg and over.

10.6 SEAT

Must be securely attached to frame, and be so constructed as to prevent slipping backwards from the proper seating position. Any padding used must be securely attached.

10.7 SUPERCHARGERS/TURBOCHARGERS

1. May be fitted at the owner's discretion.
2. It is recommended that a guard be fitted over the belt drive on superchargers mounted in front of the engine.
3. Where a supercharger is mounted behind the engine, such a guard is mandatory.
4. Where a supercharger is chain driven, guards of 3mm thick dural or equivalent strength, are the minimum requirement, irrespective of the position of the unit.
5. Explosion proof blankets fully surrounding the supercharger are highly recommended.

10.8 FRONT TYRE

Front tyres to be of road type, minimum specification 'V' rated or racing tyre specification.

10.9 WHEELS

1. All wire spoked wheels must utilise steel spokes of adequate strength and properly laced.

2. Wheels manufactured for cars may be used providing the fitting to the machine is of sound engineering.
3. All wheels must run true and all bearings must be in good condition.
4. Balance weights must be securely attached.
5. Maximum 10" tyre.

10.10 WHEELBASE

At the owner's discretion.

SECTION 11 PRO STOCK BIKE (PS)

A petrol-burning class

11.1 DEFINITION

This class will be for stock appearance (factory produced motorcycles available to the general public, modified for drag racing) petroleum burning motorcycles.

11.2 FRAMES

1. Aftermarket frames permitted.
2. Steering head geometry, trail and wheel base may be changed if done in a safe and professional manner.
3. Steering head angle may not be less than stock rake or more than 40 degrees maximum rake.
4. Maximum wheel base is 1780mm, measured from the most extendable point on the swing arm.

11.3 FRONT SUSPENSION

Minimum usable travel: 10mm, inner tube diameter minimum 34mm. Replacement front ends are allowed. Steering damper mandatory and may not act as a fork stop.

11.4 CONTROLS

1. All handlebar controls must remain in the stock location. Replacement bars are permitted. Welded aluminium handlebars are prohibited. Welded steel or chrome-moly extensions are allowed, but cannot extend more than 100mm from stock location. Minimum handlebar width 560mm.
2. Brake pedals and foot pegs may be rear set, but must be at least 380mm in front of the rear axle.
3. Throttle and clutch levers must be manually operated by the rider. Electronic, pneumatic, hydraulic or other devices may in no way affect the operation of the throttle or clutch.

11.5 BODY

1. Must have originally been produced with a 750cc or larger engine. All main body parts must have stock appearance and shape, and cannot be mixed between models.
2. Replacement parts permitted, but must retain the shape of the stock parts they replaced.
3. Lower portion of fairing may be modified for exhaust pipe clearance or removed completely.
4. Windscreen may be trimmed.
5. Must have simulated headlight and tail light of same configuration and design from specific body used, holes for air passage and aerodynamic devices prohibited unless originally incorporated into same OEM of that year.

11.6 SEATS

Custom seats with a step to prevent the rider from sliding backwards permitted. Seat, tail section and rear fender may be incorporated in one unit. Minimum seat height 500mm from lowest point of seat to ground.

11.7 WHEELS

Replacement wheels are permitted.

Front: 16" minimum, 19" maximum, or as stock.

Rear: 15" minimum.

11.8 TYRES

Front tyre minimum width 2.75". Maximum rear tyre (rubber on ground) 10".

11.9 WHEELIEBAR

Maximum length of 3300mm from centre of front axle to centre of wheeliebar axle, measured in a straight line from axle to axle. Wheels must be nonmetallic.

11.10 ENGINE

1. Engine manufacturer will determine make of bike.
2. Must be of a type specifically designed and manufactured for a production motorcycle.
3. External modifications to engine cases are not allowed except for repair purposes.
4. Aftermarket cases, EFI and side by side rod configuration permitted on V twin configuration.

11.11 CYLINDER HEAD

Cylinder head casting must be manufactured by the same manufacturer as the main engine cases. FIM Technical Steward accepted aftermarket cylinder heads permitted.

11.12 FUEL INJECTION

Is permitted. Any type or size of fuel injection and throttle bodies allowed, but must be of the open loop type i.e. fuel metering must not be controlled by computer data gathering during the run.

11.13 IGNITION

Any ignition is allowed.

11.14 FUEL

Generally available pump or racing petroleum is allowed. The use of E85 Fuel is permitted but the words 'Bio Fuel' must be clearly displayed on the tank.

11.15 WEIGHT BREAKS

Minimum weights of bike and rider at conclusion of run:

3 or 4 Cylinder	Maximum 1510cc	260kg
3 or 4 Cylinder	Maximum 1600cc	270kg
3 or 4 Cylinder	Maximum 1655cc	275kg
3 or 4 cylinder	Maximum 1755cc	280kg
3 or 4 Cylinder	Maximum 1800cc	280kg*
2 Cylinder	Maximum	2000cc
	220kg 2 Cylinder OHC or DOHC	
	Maximum	2700cc
	285kg 2 Cylinder Pushrod > 45	
degree	Maximum	2700cc
	290kg 2 Cylinder Pushrod 45	
degree	Maximum	3278cc
	265kg	

* Plain Bearing Crank only

The ACU Drag Racing Sub Committee reserve the right to make changes to weight breaks or combinations during the season. If this circumstance should arise then the changes will be published on the ACU website.

11.16 TRANSMISSION

1. Any transmission with a maximum of six forward gears, minimum three forward gears, may be used.
2. Transmission must be shifted from gear to gear manually or by air shifter.
3. RPM, computer controlled or timed shifts prohibited.
4. Transmission must be contained within the stock case, except two cylinder or two stroke engines.

11.17 ENGINE/WEIGHT CONTROL

1. In order to check the capacity of the machines of Pro-Stock Bike Finalists, both must remove the cylinder heads in the presence of the technical inspector.
2. In order to make sealing of Pro-Stock bikes possible, a 1mm hole must be made in the cylinder head and cylinder casting.
3. Riders must present themselves and their machine immediately before or after each run in both qualifying and racing, at the location specified by the organisers.
4. Failure to comply with any control procedure will render a run null and void, and could result in elimination from the competition.

SECTION 12 COMPETITION BIKE (CB)

12.1 CLUTCH AND PRIMARY TRANSMISSION

Any type, make or pattern of clutch assembly and/or drive chain/belt may be installed.

12.2 EXHAUST

Any make or type of exhaust system allowed. No flexible pipe allowed.

12.3 FRAME

1. Frame may be original factory equipment, altered or modified at the owner's discretion, or of tubular type frame construction. All butt welds must have visible reinforcement, and no grinding or filling of welds is permitted.

12.4 MUDGUARDS

1. Are not compulsory, but if fitted must be constructed of material with no sharp edges, and must be securely fitted to the machine.
2. If a stock front mudguard is removed, and an aftermarket item used, a fork brace of adequate dimensions must be fitted on machines weighing 205kg and over.

12.5 SEAT

Must be securely attached to frame, and be so constructed as to prevent slipping backwards from the proper seating position. Any padding used must be securely attached.

12.6 SUPERCHARGERS/TURBOCHARGERS

1. May be fitted at the owner's discretion.
2. It is recommended that a guard be fitted over the belt drive on superchargers mounted in front of the engine.
3. Where a supercharger is mounted behind the engine, such a guard is mandatory.
4. Where a supercharger is chain driven, guards of 3mm thick dural or equivalent strength, are the minimum requirement, irrespective of the position of the unit.
5. Explosion proof blankets fully surrounding the supercharger are highly recommended.

12.7 FRONT TYRE

Front tyres to be minimum specification 'V' rated or racing tyre specification.

12.8 WHEELS

1. All wire spoked wheels must utilise steel spokes of adequate strength and properly laced.
2. Wheels manufactured for cars may be used providing the fitting to the machine is of sound engineering.
3. All wheels must run true and all bearings must be in good condition.
4. Balance weights must be securely attached.
5. Maximum 10" tyre.

12.9 WHEELBASE

At the owner's discretion.

SECTION 13 TOP FUEL (TF)**13.1 DESIGNATION**

1. TF followed by rider number. Reserved for motorcycles running a minimum of 50% Nitromethane fuel.
2. A maximum of two engines allowed with unlimited modifications.
3. No appearance restrictions.
4. Turbo chargers and super chargers considered the same.

13.2 ENGINE

1. Displacement limited to 1700cc for supercharged 3 and 4 cylinder engines, and 2000cc for Twin cylinder supercharged engines.
2. For V8 configurations, 1350cc on each bank with a maximum of 2700cc.
3. Twin cylinder engines limited to maximum 3400cc.
4. Lower engine ballistic/restraint device recommended.

13.3 ENGINE/WEIGHT CONTROL

Super charged 4 cylinder engines: 9lb/inch³ (0.25kg/cc). V8 engines: no weight restriction.

1. In order to check the capacity of the machines of Finalists, both must be prepared to remove the cylinder heads in the presence of the technical inspector if required.
2. Riders must present themselves and their machine immediately before or after each run in both qualifying and racing, at the location specified by the organisers.
3. Failure to comply with any control procedure will render a run null and void, and could result in elimination from the competition.

13.4 BODY

All rear fenders must extend past the rear axle.

13.5 FRAME

Minimum wheel base 84 inches (2134mm).

13.6 FRONT SUSPENSION

1. Hydraulic tube type only. Minimum tube diameter 34mm, minimum travel 10mm.
2. Positive steering stops for both directions of travel mandatory.
3. Two steering dampers recommended but may not be used as steering stops.

13.7 EXHAUST

Any make or type allowed.

13.8 SUPERCHARGERS

1. Belt drive guards highly recommended for front mounts, mandatory when rear mounted.
2. If chain driven 3mm thick dural or equivalent strength mandatory irrespective of mounting position.
3. Explosion proof ballistic or restraint device highly recommended.

13.9 FUEL SHUT OFF

1. Pre-loaded fuel shut offs mandatory.
2. A lanyard is mandatory to operate a spring loaded fuel shut off valve which must completely cut off the fuel supply to the engine.
3. A separate device to completely cut off fuel supply by handlebar control is mandatory.

13.10 THROTTLE LINKAGE

1. For nitro fuelled bikes with slider clutches a throttle locking device that will positively lock the butterfly to the barrel valve linkage is mandatory.
2. It is recommended that this device is located at the butterfly end of the linkage, however, a drilled throttle twist grip with locking pin is acceptable.

13.11 WHEELS AND TYRES

1. Front Tyre must be a minimum V rating road tyre or Race Tyre Specification.
2. Rear tyre width must not exceed rim width by 2 inches. Rear wheel bead locks highly recommended.

SECTION 14 FUNNY BIKE (FB)

14.1 DESIGNATION

1. FB followed by rider number.
2. A class for single engine methanol and petrol burning machines in addition to single or double engine nitromethane burning twin cylinder machines.

14.2 CLASS REQUIREMENTS

Superchargers and turbo chargers will be considered the same.

1. All machines except those running non unitary engine and gearbox combinations must run a fuel tank, either real or dummy, in OEM stock location with the engine manufacturer's name clearly visible on both sides of the tank.
2. All bikes must have front and rear mudguards. All machines except nitro methane burning Twins must have head light or nose piece.
3. Engine: Maximum 2500cc with gears or 3278cc without gearbox. Maximum 2500cc with turbo or supercharger (petrol or methanol only)
4. Minimum rear tyre size width is 10 inches. Maximum rear tyre size width is 14 inches.

14.3 FUEL SHUT OFF

1. Pre-loaded fuel shut off is mandatory for Nitro burning bikes.
2. A lanyard is mandatory to operate a spring loaded fuel shut off valve which must completely cut off the fuel supply to the engine.
3. A separate device to completely cut off fuel supply by handlebar control is mandatory.

SECTION 15 JUNIOR DRAG BIKE (JRB)

A class for single or twin cylinder two and four stroke motorcycles built to give the appearance of a top fuel or funny bike.

For minimum age and machine restrictions please refer to Section 2.4

Requirement and Specifications:

15.1 ENGINE

Engine: Any make or model. Any configuration or engine is permitted. Small engine modifications are permitted such as: exhaust, air filter, and carburettor. Air Shifters: are permitted.

15.2 SUSPENSION AND BRAKES

1. Brakes: Front and rear mandatory (disc or drum).
2. Suspension: Front suspension minimum size 27mm and minimum travel of 2 inches. Rear suspension not permitted.

15.3 FRAME

1. Production based or purpose built utilizing a rigid rear end.
2. Rider must be able to reach all controls safely and able to place both feet flat on the ground.
3. Wheelie Bars: Mandatory.

15.4 WHEELS AND TYRES

Tyres: Slicks are permitted, any make or size. Wheels: Any make or size permitted.

15.5 BODY

1. Must have rear mudguard or body work extending past the rear axle.
2. The Seat must be securely attached so as to prevent the rider from sliding backwards.

15.6 STARTING

Electric, kick or off-board starters permitted. No push or roller starts. For any other construction rules refer to the general rules.

SECTION 16 SUPER TWINS

16.1 CATEGORIES

SUPER TWINS – A category for motorcycles with one twin cylinder engine. For unlimited capacity motorcycles, with modifications outlined in the following regulations.

These Regulations are in addition to the Drag Regulations for General Specifications for Motorcycles. Super Twin top Fuel STF

Super Twin ET Bike SET

Super Twin Top Gas STG

16.2 SUPER TWIN TOP FUEL

Designation – STF Preceded by bike number.

A class designed for motorcycles with unrestricted modifications running heads up from a pro start.

1. **Engine** Engine may be of any internal combustion type, provided that the drive is transmitted through one road wheel. Engine may be mounted in any position and any modifications are permitted.
2. **Superchargers and Turbochargers** May be fitted at the owner's discretion.
3. **Exhaust** Any make or type of exhaust system allowed. No flexible pipe allowed.
4. **Fuel Shut off**

- 1 Pre-loaded fuel shut off is mandatory for nitromethane burning machines.
2 A lanyard is mandatory to operate a spring loaded fuel shut off valve which must completely cut off the fuel supply to the engine.
3 A separate device to completely cut off fuel supply by handlebar control is mandatory.
5. **Engine Restraints** V-Twin motors running injected nitromethane must utilise cylinder head restraint. Restraints meeting SFI 46.1 are highly recommended.
6. **Clutch and Primary Transmission** Any type, make or pattern of clutch assembly and/or drive chain/belt may be install.
7. **Suspension** The minimum front fork stanchion diameter is as follows:
- | Bike weight | Diameter |
|--------------------|----------|
| 300lb (136kg) | 28mm |
| 350lb (158kg) | 30mm |
| 450lb (204kg) | 32mm |
| Over 450lb (204kg) | 34mm |
8. **Frame** Frame may be original factory equipment, altered or modified at the owner's discretion, or of tubular type frame construction. All butt welds must have visible reinforcement, and no grinding or filling of welds is permitted. Positive steering stops for both directions of travel mandatory. Steering dampers may not be used as steering stops.
9. **Alignment** Sufficient trail must be incorporated into the alignment to ensure proper handling, recommended 6 inches.
10. **Ground Clearance** Minimum of 75mm is recommended.
11. **Wheelbase** At the owner's discretion.
- 12. Tyres and Wheels**
1. Front tyre
To be of racing type, or if of road type, minimum spec 'v' rated or racing type spec.
2. Wheels
All wire spoked wheels must utilise steel spokes of adequate strength and properly laced. Wheels manufactured for car may be used providing the fitting to the machine is of sound engineering. All wheels must run true and all bearings must be in good condition. Balanced weights must be securely attached.
13. **Seat** Must be securely attached to frame, and be so constructed as to prevent slipping backwards from the proper seating position. Any padding used must be securely attached.
14. **Mudguards** Are not compulsory, but if fitted must be constructed of material with no sharp edges and must be securely fitted to the machine. If a stock front mudguard is removed and an aftermarket item used, a fork brace of adequate dimensions must be fitted on machines weighing 450lb (204kg) and over.

16.3 SUPER TWIN ET BIKE

Designation – SET Preceded by bike number.

A class designed for petrol burning street tyred bikes running to a fixed index of their choice.

1. **Engine** May be of any type with any modifications.
2. **Carburettor** Any type of carburettor or fuel injection may be used.
3. **Superchargers and Turbochargers** May be fitted at the owner's discretion.
4. **Nitrous Oxide Injection** Allowed.
5. **Exhaust** Any make or type of exhaust system allowed. No flexible pipe allowed.
6. **Clutch** Any type, make or pattern of clutch assembly may be installed. All clutches must be fully enclosed.
7. **Gearbox** Any make or type may be fitted.
8. **Suspension** Any type allowed, but if fitted must be operational. Rear struts allowed.
9. **Frame** Steering head geometry, trail and wheelbase may be altered to improve the stability of the machine, provided that all modifications are undertaken to a safe and professional standard.

Positive steering stops for both directions of travel mandatory. Steering dampers may not be used as steering stops.

10. **Stands** Must be wired up or removed.
11. **Wheelie Bars** Not allowed.
12. **Tyres and wheels**
 1. Tyres
Readily available street tyres only.
 2. Wheels
Any type and size allowed, as long as they comply with the Road Traffic Act. It is highly recommended that rear rim width should not exceed tyre width. All wire spoked wheels must utilise steel spokes of adequate strength and properly laced.
13. **Seat** Must be securely attached to frame. Any padding used must be securely attached.
14. **Mudguards** Must be fitted to comply with the Road Traffic Act.
15. **Mirrors** Mirrors should be removed or taped over.
16. **Ignition Lanyard** If the motorcycle has any aftermarket race accessory fitted, then it needs a ignition lanyard.

16.4 SUPER TWIN TOP GAS

Designation – STG Preceded by bike number.

A class designed for motorcycles with unrestricted modifications running heads up from a pro start. A petrol burning class.

1. **Engine** Engine may be of any internal combustion type, provided that the drive is transmitted through one road wheel. Engine may be mounted in any position and any modifications are permitted.
2. **Fuel** Generally available pump or racing petroleum is allowed. The use of E85 Fuel is permitted but the words 'Bio Fuel' must be clearly displayed on the tank.
3. **Superchargers and Turbochargers** May be fitted at the owner's discretion.
4. **Exhaust** Any make or type of exhaust system allowed. No flexible pipe allowed.
5. **Clutch and Primary Transmission** Any type, make or pattern of clutch assembly and/or drive chain/belt may be installed.
6. **Suspension** The minimum front fork stanchion diameter is as follows:

Bike weight	Diameter
300lb (136kg)	28mm
350lb (158kg)	30mm
450lb (204kg)	32mm
Over 450lb (204kg)	34mm
7. **Frame** Frame may be original factory equipment, altered or modified at the owner's discretion, or of tubular type frame construction. All butt welds must have visible reinforcement, and no grinding or filling of welds is permitted.
8. **Alignment** Sufficient trail must be incorporated into the alignment to ensure proper handling, recommended 6 inches.
9. **Ground Clearance** Minimum of 75mm is recommended.
10. **Wheelbase** At the owner's discretion.
11. **Tyres and wheels**
 1. Front Tyre
Front tyres to be of racing type, or if of road type, minimum spec 'v' rated or racing type spec.
 2. Wheels
All wire spoked wheels must utilise steel spokes of adequate strength and properly laced. Wheels manufactured for car may be used providing the fitting to the machine is of sound engineering. All wheels must run true and all bearings must be in good condition. Balanced weights must be securely attached.

12. **Seat** Must be securely attached to frame. Any padding used must be securely attached.
13. **Mudguards** Are not compulsory, but if fitted must be constructed of material with no sharp edges and must be securely fitted to the machine. If a stock front mudguard is removed and an aftermarket item used, a fork brace of adequate dimensions must be fitted on machines weighing 450lb (204kg) and over.

SECTION 17 ET BIKE

A Clubman licence class for machines complying with the general and safety regulations with a minimum ET of 8.70 seconds.

1. Standing regulations as per Competition Bike.
2. Machines registered with DVLA for road use and without aftermarket power adders and race aids are exempt from general regulations 6.5, 6.8, 6.11 and 6.17 but must present the V5C registration document and MOT certificate (if applicable) at technical inspection. Failure to do so will mean the exemptions will not be applied.
3. Traction control is only permitted on unmodified machines that have traction control fitted as standard OEM.
4. Riders of any machines running nitromethane as a percentage of fuel must be holders of a National Licence.
5. **Qualifying order:**
For all riders that have an ET that is the same as the class index/personal dial in index or slower, the time closest to that index is used to determine qualifying position. For drivers that have ETs that are quicker than the class index/personal dial in index, the slowest time is awarded the higher qualifying position.
In the event of identical qualifying elapsed time within 1/1000 of a second, the driver who made the run first will receive the better qualifying position. If qualifying cannot take place, random pairing will be used.
6. If weather conditions or other event delays should disrupt posted lane rotation for qualifying runs, the Clerk of the Course has the option of reassigning lanes as necessary for remaining runs. Every effort will be made to see that qualifying contestants have the opportunity to run in each lane.

SECTION 18 ACU/UK DRAG BIKE CHAMPIONSHIP

18.1 CLASSES

Riders who wish to enter the championship should register with the championship coordinator. The classes will be as follows:

1. **SUPER STREET** Modified street motorcycles running heads up.
2. **PRO STOCK** Ultimate street appearing class.
3. **COMPETITION BIKE** Motorcycles designed to run on the quarter mile with unrestricted modifications.
4. **FUNNY BIKE** As per ACU Regulations.
5. **TOP FUEL BIKE** The ultimate Drag racing motorcycle, designed to run on the quarter mile with unrestricted modifications.
6. **JUNIOR DRAG BIKE** Reserved for non-street legal single or twin cylinder two and four stroke motorcycles built to give the appearance of a top fuel or funny bike. For minimum age and machine restrictions please refer to Section 2.4.

Note: A minimum of two events per class to comprise the Championship.

18.2 ELIGIBILITY

1. Open only to holders of current Drag Race Licences issued by:
a) The Auto Cycle Union. b) The Scottish Auto Cycle Union. c) EU Federations.

2. For all ACU Championships an ACU decal, supplied by the ACU Secretariat, must be displayed on each machine. Any competitor not complying will be disqualified from the results of the race.

18.3 SpECIFICATIONS

Motorcycles must comply with the Standing Regulations and the class structure as outlined in this book.

18.4 CLASSIFICATION

1. At the conclusion of the Series all points scored will be added together and the rider with the highest number of points will be declared the winner.
2. Where a class is run at more than five rounds additional rounds may be non-scoring. Number of scoring rounds to be announced prior to the start of the championship.

18.5 pOINTS

Points at each round will be allocated as follows:

1. Attendance points: Each competitor who has signed on and whose machine has passed technical verification – 100 points.
2. Qualifying Points: 10 points will be allocated per qualifying position from last qualifier upwards, i.e. last qualifier 10 points, second from last 20 points and so on in increments of 10 points per position.
Eliminations: 100 points for each winning run.
Bonus points:
Event Low ET 25 points Championship Record ET 100 points
Event High TS 25 points Championship Record TS 100 points
In the event of a rain off points are scored up to the last complete round of qualifying or elimination.
3. If the race distance is reduced after commencement of an event, due to adverse weather or track conditions, then bonus points will only be awarded to those riders establishing the low ET or high mph over the distance for which the last complete round of qualifying or eliminations has been contested.

18.6 TIES

In the event of a tie between riders for first place in a Championship after the conclusion of all rounds, the winner will be determined in the following manner:

- a) The rider who has won the most races during the Championship. If there is still a tie, then:
- b) The rider who qualified highest at the final round of the Championship.

18.7 AWARDS

The overall winner per class will receive an ACU trophy (1 year retention) to be presented at the annual presentation ceremony. There will be an end of season ACU prize fund.

18.8 pUBLICITY

Round Promoters and Organising Clubs must give maximum publicity to the Championship before and after each round. The current up-to-date positions of the Championship and current Championship records must be given in the programme at each round.

18.9 ABANDONMENT

In the event of a round being interrupted or abandoned by bad weather, the following conditions will apply:

1. Qualifying

If less than 75% of the total number of competitors entered in a class have made qualifying runs, the Emergency QTs (Emergency Qualifying Times) will be used.

1. If more than 75% have made qualifying runs, then EQTs will only be used for the competitors who were unable to run. Everyone else will be paired by the QTs they were able to record.

2. A record of championship EQTs will be maintained and will be the competitors quickest time from the past 2 championship meetings.

3. In the case of one or more identical times arising in the same class, the next quickest time will be considered, with the lowest ET taking precedence in the pairing selection.

4. When no previous ET has been recorded, competitors concerned will assume the lowest positions in their class if there are vacant spots.

5. When qualifying positions are determined by EQTs their fields will be on an all run basis.

2. Racing

1. In the event of racing being terminated, before conclusion, points will be awarded up to the last complete round of competition.

3. Subject to the prior written approval of the promoter the following shall apply:

1. In the event of the race being terminated before conclusion any class prize monies not awarded to riders at that point will be equally divided within the particular class to those riders still remaining in the competition.

2. In the event of a race being terminated before eliminations have commenced then first round loser monies for a particular class will be awarded to each competitor in that class who has signed on and whose machine has passed technical verification.

18.10 ESTABLISHING RECORDS

1. For all records the following criteria must be satisfied:

1. The vehicle must comply with all class regulations, Technical Crew decisions will be final.

2. Records can only be set during qualifying or eliminations, practice run performances will not count.

3. In order to ensure the validity of all new records, a back up performance of within 1% of the mark is required at the same event. In the event that two runs exceed the existing records but are not within 1% of each other, the quicker time or faster speed will be acceptable as the back up for the slower time, which will stand as the new record.

4. Only the driver/rider holding the record at the conclusion of the event will be credited with the record. A driver/rider setting and then losing a record at the same event will not receive credit for establishing a record, or receive points for doing so.

18.11 QUALIFYING

The following minimum number of qualifying sessions will be held:

2 day qualifying - 4 sessions (2 per day) 1 day qualifying - 3 sessions Track conditions permitting. There will be compulsory alternate lane qualifying. For first qualifying run pairs should be run where possible, lane choice for first qualifier is at the discretion of the start crew and singles should be restricted to one only per session, track conditions permitting.

A valid qualifying run must be made under engine power and an E.T. and/or T.S. must be recorded. If the race distance is reduced before the conclusion of qualifying then the positions in the ladder will be established over the distance for the last complete round of qualifying.

18.12 CHOICE OF LANE

- I The rider with the quickest time from the preceding round will have lane choice.

18.13 ELIMINATION LADDER AND FIELD SIZES

Professional ladders will be used. All classes will be operated on an all qualified basis up to a 8 bike maximum field. Above that number the fields will be set on the following basis:

9–12 Qualifiers	8 Bike field
13–24 Qualifiers	16 Bike field
24+ Qualifiers	32 Bike field

A minimum of 3 entered riders are required to comprise a class.

18.14 ALTERNATES

Once qualifying has concluded and a ladder has been established, pairings will not be changed. However, should a qualified bike and rider be unable to make the first round of eliminations (not reach the burnout water area) an alternative will be inserted in their place. The quickest non-qualifier will take the first available space, the second quickest non qualifier the next available space and so on.

18.15 STAGING

Both riders must be in pre-stage before either rider can stage. In any case riders must stage when instructed to do so by the Start line Marshal.

18.16 FIRST OR WORST pROCEDURE

If both riders commit a foul during a race the rider committing the worst foul would be disqualified. If both riders commit the same foul then the first rider to commit the foul is disqualified. The following is the list of fouls in descending order (i.e. 1 is the worst).

1. Contact with the guard rail barriers, or any other track fixture (i.e. Christmas tree, timing equipment, cones etc.) is grounds for disqualification.
2. Crossing any part of the track centreline.
3. Red light.
4. Crossing any part of the lane boundary lines.
5. Pushing the machine over the finish line.

NB. On a solo bye run a competitor is considered the winner once he stages his machine under power and the start sequence is initiated.

18.17 MACHINE WEIGHING

It is the responsibility of the Clerk of the Course to weigh machines before or after each qualifying or elimination run where weight brakes are in force.

18.18 SERIES CO-ORDINATOR

The Series will be co-ordinated by:

Mr. I. King, 11 Cockhall Close, Litlington, Royston, Herts SG8 0RB.
Mobile: 07470 396685 email: ian@kingracing.com.

18.19 RACE RESULTS

A list of ALL competitors who have signed-on, qualifying lists and elimination ladders, highlighting fastest time and highest speed for the class (including qualifying) and any records established at the event must be submitted to the Road Race Department and the Series Co-ordinator within two days of the event, by fax, mail or email.

Hillclimb and Sprint

Standing Regulations

SECTION 1 MEETINGS

1.1	Categories of Meetings	350
1.2	International	350
1.3	European Open	350
1.4	National	350
1.5	Open	350
1.6	Restricted	350
1.7	Eligibility of Foreign Riders in Open and Restricted Meetings	351
1.8	Practice Meetings and Test Days	351
1.9	Conditions for Hill Climb, Sprint and Twisty Sprint Meetings	351

SECTION 2 LICENCES – COMPETITORS

2.1	General	351
2.2	Grades	351
2.3	Lapsed Licences	352
2.4	Capacity and Licence Restrictions	352

SECTION 3 LICENCES AND REGISTRATIONS – OFFICIALS

3.1	Qualifications and Conditions	353
3.2	Hill Climb, Sprint and Twisty Sprint Officials who require a Licence	353
3.3	Grades for Clerk of the Course	353
3.4	Hill Climb, Sprint and Twisty Sprint Officials who do not require a Licence	354

SECTION 4 START AND FINISH PROCEDURE

4.1	Timing Equipment	354
4.2	Starts	355
4.3	Finish	355

SECTION 5 FLAGS AND LIGHTS

5.1	Flags and Lights Used to Provide Information	355
5.2	Flags Which Convey Information and Instructions	355
5.3	Flag Dimensions	356
5.4	Flag Colours	356

SECTION 6 BEHAVIOUR AT A MEETING 356**SECTION 7 SAFETY**

7.1	Medical Services Minimum Requirements for Hill Climb and Sprint Meetings	356
7.2	Track Safety Precautions	357
7.3	Fire Extinguishers	358
7.4	Fire Extinguishers at Circuits	358
7.5	Warning and Prohibition Signs at Circuits	358
7.6	Declaration – Admission Tickets, Armbands and Passes	359
7.7	Declaration on the Official Programme	359
7.8	Signing On	359

SECTION 8 TECHNICAL SPECIFICATIONS

8.1	Drive	359
8.2	Brakes	360
8.3	Tyres	360
8.4	Mudguards	360

8.5	Clutch and Brake Levers	360
8.6	Primary and Auxiliary Devices	360
8.7	Throttles	360
8.8	Handlebars	360
8.9	Superchargers	360
8.10	Fuel	360
8.11	Footrests	361
8.12	Oil Drain Plugs and Supply Pipes	361
8.13	Oil Catch Tanks	361
8.14	Number Plates	361
8.15	Control of Exhaust Sound Level	362
8.16	Exhaust Pipes	362
8.17	Construction	362
8.18	Streamlining for Sprint Machines	362
8.19	Sprint Additional Specifications for Solo Machines 1300cc and over	362
8.20	Hill Climb and Twisty Sprint – Additional Specifications for Three Wheel Machines	363
8.21	Sprint – Additional Specifications for Three-Wheelers	363

SECTION 9 PROTECTIVE CLOTHING

9.1	Protective Clothing	363
9.2	Body Jewellery	364
9.3	Helmets	364
9.4	Identification Discs	364

SECTION 10 RUN WHAT YOU BRUNG – CLASSES FOR ROAD LEGAL MACHINES

10.1	Definition	364
10.2	Eligibility	364
10.3	Machine Eligibility	364
10.4	Technical Control	364
10.5	Protective Clothing	364

SECTION 11 ACU SPRINT CHAMPIONSHIP QUALIFYING ROUNDS (TO BE ANNOUNCED)

11.1	Title	365
11.2	Eligibility	365
11.3	Classes	365
11.4	Points	365
11.5	Overall Classification	365
11.6	Ties	366
11.7	Results Return Method	366
11.8	Technical Specification	366
11.9	Protective Clothing	366

SECTION 12 SPRINT RECORD ATTEMPTS

National Sporting Code of the ACU and the Standing Regulations together with the Supplementary Regulations and any Final Instructions shall apply to all Hill Climb and Sprint Races and Twisty Sprint held under an ACU Permit.

SECTION 1 MEETINGS

1.1 CATEGORIES OF MEETINGS

- International Meetings
- European Open Meetings
- National Meetings
- Open Meetings
- Restricted Meetings

Permits for all Hill Climb, Sprint and Twisty Sprint competitions are issued by ACU Headquarters.

1.2 INTERNATIONAL

1. The Permit shall be issued by the ACU Headquarters for a meeting inscribed on the International Calendar of the FIM and having an FIM International Meeting Number (IMN).
2. An International meeting is open to Entrants and Riders of more than one nation who must hold an International Licence or a National Licence issued by the ACU valid for the particular meeting concerned.
3. All riders not holding a Licence issued by the ACU or SACU must carry proof of Insurance and a written Start Permission document issued by their FMN.

Note: This includes all riders holding a licence issued by the MCUI.

1.3 EUROPEAN OPEN

1. The permit shall be issued by ACU Headquarters for a meeting inscribed on the Calendar of the Fédération Internationale de Motocyclisme Europe (FIME) and having a European Meeting Number (EMN).
2. A European Open meeting is open to Entrants and Riders of more than one European nation who must hold the appropriate Competition Licence valid for the particular meeting concerned.
3. All riders not holding a Licence issued by the ACU or SACU must carry proof of Insurance and a written Start Permission document issued by their FMN.

Note: This includes all riders holding a licence issued by the MCUI.

1.4 NATIONAL

1. The Permit shall be issued by the ACU Headquarters.
2. A National meeting is open to Entrants and Riders who are the holders of a National or International Licence valid for the particular meeting concerned issued by any Federation.
3. All riders not holding a Licence issued by the ACU or SACU must carry proof of Insurance and a written Start Permission document issued by their FMN.

Note: This includes all riders holding a licence issued by the MCUI.

1.5 OpEN

1. An Open permit is issued by ACU Headquarters.
2. An Open meeting is open to Entrants and Riders who hold a valid ACU or SACU Licence for the meeting concerned.

1.6 RESTRICTED

1. A Restricted Permit is issued by ACU Headquarters.
2. A Restricted meeting is open to Entrants and Riders who hold a current ACU Licence valid for the meeting concerned.

3. The Supplementary Regulations issued for the event must specify all restrictions and requirements of eligibility.

1.7 ELIGIBILITY OF FOREIGN RIDERS IN OPEN AND RESTRICTED MEETINGS

1. The Supplementary Regulations issued for the event must specify the licence qualification and eligibility requirements of foreign riders.
2. All riders must have a current Licence and Start Permission from their own Federation valid for the event.

1.8 PRACTICE MEETINGS AND TEST DAYS

1. Permits for Practice Meetings and Test Days may be issued on application to the Permit Issuing Authority.
2. No such event may be held unless the appropriate Permit and Insurance has been issued.

1.9 CONDITIONS FOR HILL CLIMB, SPRINT AND TWISTY SPRINT MEETINGS

1. The ACU Road Race Committee must approve the Organiser.
2. The Venue must hold a current Track Licence or Track Certificate issued by the ACU Road Race Committee.
3. The ACU Secretariat must approve the Supplementary Regulations for the event and issue an ACU Permit prior to publication and circulation.
4. For all ACU Championships an ACU decal, supplied by the ACU Secretariat, must be displayed on each machine. Any rider not complying will be disqualified from the results of the race.
5. The Race Control must remain operative with all equipment in place until the end of the period provided for the lodging of a protest, and all officials and marshals must remain at the circuit and available to the Clerk of the Course and the Stewards during that period.
6. Where a class is cancelled because of insufficient entries the organisers may merge such entries with the next higher capacity class.

SECTION 2 LICENCES – COMPETITORS

2.1 GENERAL

1. To participate in events an annual Licence issued by the ACU is required. Residents in Scotland apply to the Scottish ACU.
2. A Licence can be upgraded at any time during the year.
3. The parent or legal guardian must accompany all competitors, or participants in parades, under 18 years of age to every meeting. This person must attend at signing-on and be present throughout the meeting.
4. A One – Event Licence is available to Competitors resident in the UK. For meetings up to National Level.

2.2 GRADES

1. **Clubman** Entry Level for first time applicants.
2. **National.** After competing satisfactorily in 10 separate race days during the current year and preceding 3 years a Clubman Competitor may apply to be upgraded to a National licence.
3. **International.** National licence holders who have competed at 5 race days may apply for an FIM Non-Championship International Licence.
A medical examination is required.
4. **International Championship.** National licence holders who have competed at 5 race days may apply for a FIME or FIM Championship licence as described in the appropriate Sporting Code. A medical examination is required.

2.3 Lapsed Licences

1. **Clubman.** Clubman licence holders who have allowed their licence to lapse for more than 5 years will be re-issued with a Clubman licence.
2. **National.** National licence holders who have allowed their licence to lapse for more than 5 years will be re-issued with a Clubman licence.

2.4 Capacity and Licence Restrictions

For each category the table indicates the Class, ages and machine specifications.

1.

Minimum Age	Licence	Grade of Capacity of Machine
8 yrs	Clubman	50cc automatic Machine
11 yrs	Clubman up to	125cc Production Scooter Automatic
12 yrs	Clubman up to	125cc Production up to 250 single cylinder 4 stroke production machine (restricted)
13 yrs	National up to	125cc GP Machine up to 250cc single cylinder 4 stroke machine (unrestricted)
14 yrs	Clubman up to	125cc GP Machine up to 350cc single cylinder 4 stroke machine (unrestricted)
15 yrs	National	up to 500cc twin Cylinder, 4 Stroke Production Based Machine
16 yrs and over		No restrictions

2. Junior riders 16 yrs of age and under

1. Junior riders must satisfy the Clerk of the Course for the meeting that they can ride and control the machine they have entered before being permitted to race at that meeting.
2. Junior riders are restricted to a maximum Sprint of 1/4 mile.
3. When a rider reaches the maximum age limit for his class, he may continue to compete in that class until the end of the calendar year or upgrade on his birthday.
4. A junior rider may only compete in one class. Any junior rider being issued with an adult licence cannot revert back to junior status.
5. For Junior Classes superchargers and turbochargers are not permitted. For Junior classes rebore are permitted to a maximum increase in engine capacity of 3cc.

3. Straight Line Sprint speed restrictions applicable to riders who are 14 years of age and under or who are riding a machine suitable for a rider of 14 years or under.

1. Riders are restricted to a minimum ET of 14.5
2. A rider recording an ET of 0.2 seconds or quicker below their class minimum will receive one warning.
3. A repetition of the offence at the same event will result in disqualification from the remainder of the event.
4. However, a rider recording a time of 0.4 seconds or quicker below their class ET or exceeding 80mph will be immediately disqualified from the event.

Important Notice

If a participant is under 18 years of age he/she must be accompanied to every meeting by their Parent or Legal Guardian. The Parent or Legal Guardian must attend signing on with the competitor and be available for the duration of the meeting.

SECTION 3 LICENCES AND REGISTRATIONS – OFFICIALS

3.1 QUALIFICATIONS AND CONDITIONS

Hill Climb, Sprint and Twisty Sprint Officials are divided into two categories: Those that are Licensed and those that are Registered.

Fees are payable in respect of any Licences or Registration or for the appropriate form of identification issued.

Licences: Senior Hill Climb, Sprint and Twisty Sprint Officials are required to hold an ACU Licence of the appropriate Grade for the performance of their duties.

Registration: A Register is maintained of Officials not required to hold a Licence.

3.2 HILL CLIMB, SpRINT AND TWISTY SpRINT OFFICIALS WHO REQUIRE A LICENCE

All the following licences are valid for 3 years.

	See Note Below	Attendance at Seminar/Training Session
Clerk of the Course	1	Every third year maximum
Chief Steward	2	Every third year maximum
Chief Technical Officer	3	Every third year maximum
Sound Inspector		Required for First Issue only
Measurer	4	Required for First Issue only
Timekeeper	5	Equipment and operators check

Clubs and Centres shall only nominate candidates whose aptitude and integrity for the position they can fully justify. Official ACU approval and the issue of a Licence is only after the candidates have proved to be competent according to the special requirements for each discipline. The respective Committees and Panels organise Seminars that are compulsory for certain Officials.

3.3 GRADES FOR CLERK OF THE COURSE

- Probationary** Any club may nominate a Probationary Clerk of the Course. Such a Registered Official may only act as an Assistant Clerk of the Course at a Club event.
- National Grade D** A Clerk of the Course who may officiate at any Club, National Restricted or National event for Hill Climb, Drag, Sprint and Twisty Sprint. May officiate as a Deputy to a National Grade E Clerk of the Course.
To upgrade from a National D to a National E a licence holder must officiate as a National D Clerk of the Course at 5 events. He must act as a Deputy to a National E Clerk of the Course at 5 events and be recommended by the Clerk of the Course at each. In addition members of the Road Race, Drag and Sprint Committee may be appointed to observe him. A club must nominate him as being required to take charge of a specific future event.
- National Grade E** A Clerk of the Course who may officiate at any event held under an ACU Permit for Hill Climb, Drag, Sprint and Twisty Sprint. May officiate as a Deputy or Assistant to an FIM or FIME International Clerk of the Course for Hill Climb, Drag, Sprint and Twisty Sprint.

Note 1 Clerk of the Course

AGE LIMITS:

Licences for Clerks of the Course who have attained their 70th birthday will be reviewed annually. Officials will be required to satisfactorily attend a seminar annually. The issuing of a licence will be subject to Road Race Committee approval.

Note 2 Chief Steward

Grading: There is only one grade of Steward's Licence for all Road Race disciplines.

Age Limits: Stewards may not normally officiate beyond the end of the season in which they attain

their 70th birthday. The Road Race, Drag and Sprint Committee will review Stewards who reach the age of 70 for appointments on an annual basis.

Note 3 Chief Technical Officer

The Chief Technical Officer may be a Senior Technical Official or a Registered Technical Official to be in charge of the Technical Control at an event.

Note 4 Measurer

The Measurer is required for ACU National Championships and National events. The Licence is issued by the Technical Panel and may be restricted by discipline.

Note 5 Timekeepers

Will be required to pay for their Licence.

Licence Fees:

All licences (exception Timekeepers licences) will be issued, free of charge, for a period of three years. A fee may be charged for attendance at all Seminars organised by the Road Race Drag and Sprint Committee or the relevant Panel.

3.4 HILL CLIMB, SPRINT AND TWISTY SPRINT OFFICIALS WHO DO NOT REQUIRE A LICENCE

See Note Below Attendance at Seminar/Training Session

Incident Officer	1	Refer to Note 1
Secretary of the Meeting	2 and 4	Will receive Training at meetings and if required at Regional or ACU HQ Seminars
Technical Official		Will receive training via the Chief Technical Officer at meetings May attend Regional Training Seminars
Club Stewards	3	May attend Regional or ACU HQ Seminars for information purposes
Chief Marshal		May receive training at ACU HQ or Regional Training Days
Marshal		May receive training at Regional Training
Medical Officer		None required

Registration of the above officials and marshals will be renewed annually and they will receive an appropriate form of identification from the ACU.

Note 1 Incident Officer

Will collate all information and documentation, and prepare reports relating to serious accidents and to all incidents involving Officials or Spectators.

For 2019 it is recommended that the Incident Officer is at least a Probationary Clerk of the Course or has attended an Incident Officer Seminar.

For 2020 and onwards the Incident Officer will be required to hold at least a Probationary Clerk of the Course licence or have attended an Incident Officer Seminar.

Note 2 Secretary of the Meeting

Will be responsible for all administration connected with the organisation of a meeting.

Note 3 Club Stewards

Will together with the Chief Steward form the judicial authority over the running of the meeting.

Note 4 Secretary of the Meeting Registration

Currently there is no requirement for these officials to be Registered for Road Race Disciplines.

SECTION 4 START AND FINISH PROCEDURE

4.1 TIMING EQUIPMENT

1. Unless otherwise provided for in the Supplementary Regulations, the timing apparatus shall not be placed beneath the wheels of the motorcycle in order to actuate the timing equipment.

2. The ACU grade of the timing apparatus must be stated in the Supplementary Regulations.

4.2 STARTS

1. Starts shall be made from a stationary position with the engine running and foremost part of the motorcycle a distance of 100mm behind an actual start line or a stage beam set 100mm behind a start beam. A single or 2 beam system may be used.
2. A chock may be placed against a rear wheel of the motorcycle upon lining up with the 100mm mark and may be retained in position.
3. A rider must start within one minute of receiving the start signal. Any rider failing to start within this period may be disqualified.
4. A rider will be deemed to have started when his machine actuates the timing equipment.

4.3 FINISH

1. The finishing line shall be clearly marked and defined by a chequered flag or board.
2. The limit of the braking area shall be clearly defined. The distance of the braking area must be stated in the Supplementary Regulations. If ropes are used, coloured streamers (minimum 300mm in length) must be attached at intervals of not more than 2 metres.

SECTION 5 FLAGS AND LIGHTS

Marshals and other officials display flags or lights to provide information and/or convey instructions to the riders:

5.1 FLAGS AND LIGHTS USED TO pROVIDE INFORMATION

1. GREEN FLAG

1. The track is clear.
2. This flag must be shown motionless at each flag marshal post for the first practice run to indicate the flag marshal posts.

2. YELLOW AND RED STRIPED FLAG (OPTIONAL)

1. The adhesion on this section of the track could be affected.

3. CHEQUERED BLACK/WHITE FLAG OR BOARD

1. This flag or board will be displayed to indicate the finish line.

5.2 FLAGS WHICH CONVEY INFORMATION AND INSTRUCTIONS

1. YELLOW FLAG (OPTIONAL)

1. Shown waved at the flag marshal post, this flag indicates that there is a danger ahead.
2. The riders must slow down and be prepared to stop.
3. Any Infringement of this rule during a run will result in the cancellation of the time of the run during which the infraction occurred.
4. Further penalties (such as fine – suspension) may also be imposed.

2. RED FLAG AND RED LIGHTS

1. When the run is being interrupted, the red flag will be waved at each flag marshal post and the red lights (where provided) switched on. Riders must stop and await instructions.
2. Any infringement of this rule will be penalised with one of the following penalties: fine – disqualification – withdrawal of Championship points – suspension.

The red flag may also be used to close the track.

5.3 FLAG DIMENSIONS

The flag dimension should be approximately 80cms in the vertical and 100cms in the horizontal.

5.4 FLAG COLOURS

The Pantones for the colours are as follows:

Red: Pantone 186C
 Yellow: Pantone Yellow
 CGreen: Pantone 348C

SECTION 6 BEHAVIOUR AT A MEETING

- 6.1 Riders are not allowed to transport another person on their machine or to be transported by another rider on his machine.
- 6.2 Solo riders must adopt a position with their feet on the footrests.
- 6.3 Riders who fall from their machine are not permitted to continue in the meeting until passed fit by the Medical Personnel and the machine re-inspected by technical control. In the event of a serious accident organisers may impound any machines, equipment or clothing of riders involved in the accident.
- 6.4 Riders must not ride or push their motorcycles in the opposite direction of the circuit, unless doing so under the direction of an Official.
- 6.5 The carrying of on board cameras is only permitted with the prior approval, in writing of the Clerk of the Course. Cameras must only be fixed to the machine, they must NOT be attached to the rider or passengers helmet. The installation of the camera must be approved by the Chief Technical Officer prior to the machine's first practice session.
- 6.6 Stopping on the track during a run is forbidden except for machine failure.
- 6.7 The spinning of rear wheels (burn-outs) is strictly forbidden on the track, with the exception of the start area. Breach of this rule will result in a penalty of disqualification.
- 6.8 All competitors finishing an event must submit the machine for final examination if required. The organisers may retain that machine for a reasonable period to allow for that examination.
- 6.9 Any competitor who in any ACU or MCRCB Permitted Event participates on a machine for which he is not eligible through age or licence restrictions will be penalized by a fine of £500.00 and a suspension for one year from the date of the hearing.

SECTION 7 SAFETY

7.1 MEDICAL SERVICES MINIMUM REQUIREMENTS FOR HILL CLIMB AND SPRINT MEETINGS

	PERSONNEL			VEHICLES		
	Doctors MO	Paramedic(s) PM	First Aid personnel	Ambulance(s)	Fast Intervention Vehicle	Special Notes
Sprint and Hillclimb	1 MO or 1PM		2	1		

The following applies to all events run under this code.

1. Medical Officer (MO) – Doctor A medical practitioner (doctor) fully registered with the General Medical Council (GMC), and holding appropriate personal medical malpractice insurance cover (excludes NHS Crown Indemnity)
2. Paramedic (PM) A State Registered Paramedic with the HPC (Health Professionals Council) Paramedics must have appropriate personal medical malpractice insurance cover.
3. Ambulance A vehicle registered as an ambulance with the DVLA (Driver and Vehicle Licensing Agency) and registered with CQC if appropriate. An ambulance must have an appropriately

qualified driver to transport a casualty under blue lights. It must be equipped with the FIM minimum equipment regulations for a type C vehicle; that is
Medical: A stretcher (preferably standardised), oxygen supply, apparatus to immobilise limbs and vertebral column. First aid medicaments and materials.

Technical: Radio communication. Visible and audible signals.

Staffing: An ambulance must be staffed by two First Aid Personnel (who can be the two minimum First Aid Personnel). An ambulance may act as a Medical Centre BUT if so it must be a vehicle in addition to the minimum ambulance requirement.

4. **First Aid Personnel** A person holding a current certificate of First Aid competency. (Where an event is open to the public event organisers should ensure that all First Aid personnel are insured against malpractice for the event concerned).

Special Notes

The minimum medical requirements specific for this discipline also apply to associated Test Days.

5. **Medical Examination** At any time during a meeting the Clerk of the Course may require a competitor to undergo a medical examination to determine his fitness to ride. The decision of the Medical Officer is a matter of fact without right of protest.
6. **Concussion/suspected concussion** If a competitor is involved in an incident which results in him being diagnosed by the Medical Officer/Paramedic as suffering from concussion/suspected concussion, the rider is not permitted to participate any further in that event.

Organisers are to notify ACU Head Office as soon as possible of any concussion/suspected concussion injuries and then will subsequently:

- a) Place the rider on the ACU Stop List
- b) Inform Organisers of forthcoming events that the Rider has suffered a concussion/ suspected concussion injury and is therefore placed on the ACU Stop List
- c) Inform the Rider that he needs to see a Doctor and obtain a letter/doctor's certificate which confirms he is fit to resume competitive racing/participate in a practice/test session.

The recovery time for anyone diagnosed with concussion/suspected concussion is as follows:

- a) Over 20 years: Excluded immediately and suspended for a period of nine days.
- b) 16–19 years: Excluded immediately and suspended for a period of twelve days.
- c) 15 and under: Excluded immediately and suspended for a period of twenty three days. The rider is not permitted to ride during the obligatory suspended periods outlined above and then only once he is in possession of a doctor's certificate/letter after the suspended period has expired.

A rider may be signed off to ride by the CMO at an event once he has observed the obligatory suspended period outlined above.

If a competitor has been injured on a Saturday and is suffering from concussion/suspected concussion, and the Organiser is aware that the rider was intending to ride or is scheduled to ride somewhere else the next day, the Organiser will inform the Organiser of the event being held the next day so they are aware of the rider's injuries and as such he is prevented from participating in that event.

7.2 TRACK SAFETY PRECAUTIONS

1. The safety precautions of circuits will be as laid down for each Permanent Course Licence or Temporary Course Certificate following an inspection of the course.
2. It should be generally realised that the organisers of speed events have a legal responsibility to the general public and therefore it is the duty of these organisers to ensure that all reasonable precautions are taken to protect the public.
3. Whilst organising clubs are insured under the Promoters Third Party Policy in respect of their legal liability, it is a condition of the policy that the promoters of an event must comply strictly

with the National Sporting Code and any additional requirements as may be specified by the Permanent Course Licence or Temporary Course Certificate.

Clubs failing to do so stand in grave danger of any claims being repudiated to the club by the insurers under the terms of the policy covering legal liability.

4. The safety precautions to be adopted are provided with the Permanent Course Licence or Temporary Course Certificate for the particular course but the following general requirements must be observed.
5. The attention of organisers is drawn to the provision of the NSC which stipulates that no alteration of the requirements contained in the Permanent Course Licence or Temporary Course Certificate shall be made without the prior approval, in writing, of the ACU.
6. It is recognised that circumstances may arise in which it is necessary to make certain alterations to the course on the day of the meeting but any such alterations must be approved by the Stewards of the Meeting and details given in their report to the authority granting the permit.

7.3 FIRE EXTINGUISHERS

Each working vehicle in the Paddock must have a 2kg (minimum) dry powder fire extinguisher available for immediate use. This extinguisher must show the date of the last annual inspection. Non-compliance with this regulation will incur a penalty imposed by the Clerk of the Course.

7.4 FIRE EXTINGUISHERS AT CIRCUITS

At all race and speed events, there must be a valid certificate, issued annually immediately prior to the start of each season's racing by the manufacturer or his agent, to the effect that all fire extinguishers are in effective working order. This certificate must be available for inspection by the Stewards.

All fire posts must be clearly marked. In addition to the fire equipment at each post there must be:

1. Fire extinguishers in the paddock and assembly area.
2. At least two fire extinguishers in the Technical Control Area.
3. Fire extinguishers in every medical room/centre.

7.5 WARNING AND PROHIBITION SIGNS AT CIRCUITS

For full details regarding Warning Notices and Prohibition Notices please refer to the Safety Precautions section of this Handbook.

1. WARNING NOTICES

The following requirements regarding the display of Warning notices are applicable to all Hill Climb and Sprint events.

1. WARNING NOTICE (A) (29 × 20 inches.) Warning notices as detailed below must be displayed on each side of every entrance to the course, including the entrance to car parks and paddock. These notices must be prominently displayed where they can be easily read by the public before any admission charge is paid, or where no admission charge is made before entry is gained into the circuit.
Where it is not possible to define the limits of the site and to control admission of the public (e.g. War Department and heath land) warning notices must be profusely displayed around the course and also in the car parks.
2. WARNING NOTICE (B) (20 × 15 inches.) Those parts of the course to which the public may be admitted and where it is neither practical nor necessary to erect a barrier, e.g. those parts of the course which are straight and are only used by the public to reach other parts of the course, may be indicated by the erection of the special type of Warning Notice (B). These notices should be displayed at least 30ft from the course. It is recommended that the limit of these areas should also be defined by a boundary tape.

2. PROHIBITION NOTICES

The following requirements regarding the display of Prohibition notices are applicable to all Speed events.

PROHIBITED AREA NOTICE (C) (29 × 20 inches.) Areas where the public are not permitted must be clearly defined by the display of an adequate number of "Prohibited Area" notices (B). Notices should be displayed within the prohibited area, facing the public.

7.6 DECLARATION – ADMISSION TICKETS, ARMBANDS AND pASSES

Subject to the provision of the Sunday Observance Act 1780, no person may be allowed to any part of the circuit without a suitable pass or ticket. All tickets and passes must bear the following wording shown below in full and if the wording appears on the reverse side then the words "For Conditions of Admission See Over" must be clearly printed on the face thereof. Where a ticket is cancelled by being torn in half, the full wording and, where applicable, the "For conditions of admission see over" must appear on each half. Where a charge is made for admission into special or "reserved" enclosures a ticket bearing the approved declaration must be issued in exchange for payment to enter these enclosures.

Declaration.

WARNING. MOTOR SPORT CAN BE DANGEROUS. Despite the organisers taking all reasonable precautions, unavoidable accidents can happen. Please comply with all instructions of the marshals and notices and remain in permitted areas only. THEY ARE CONCERNED WITH YOUR SAFETY.

All vehicle passes must bear the same wording and comply with the above requirements.

7.7 DECLARATION ON THE OFFICIAL PROGRAMME

The declaration as outlined above should be printed in full on the outside front cover of all Official Programmes. Where this is not possible it must be printed in full in the programme and the words "For conditions of admission see inside" printed on the outside cover.

7.8 SIGNING ON

All riders, passengers, officials and assistants, press and team crew must sign a declaration on the relevant signing on form (available from the ACU).

1. Age Limits for Officials
All event Executive and Administrative Officials shall be 18 years of age or over.
2. Age Limits for Marshals
 1. All Assistant Officials whose function is to be carried out at the immediate track-side must be at least 16 years of age.
 2. All Assistant Officials who are under 18 years of age must have obtained parental agreement to carry out the duty and the signing-on signature must be countersigned by the person responsible for the official at the event.
3. When using the services of officials under 18 years of age for any duties at any event special attention must be given to any risks which may be associated with the duty, and to the previous experience of the official.

SECTION 8 TECHNICAL SPECIFICATIONS

Specification of motorcycle Motorcycles must be of Solo Category I, Group A1 or Category II, Group F, Sidecars, Category I, Group B1 or B2 or Category II Group F (Sprint and Drag Racers), Three Wheelers, Category I, Group B3 or Category II, Group F.

8.1 DRIVE

The drive to the machine shall be only through the road wheel or wheels.

8.2 BRAKES

1. Solo motorcycles must be equipped with one efficient brake operating on each wheel, and operated independently.
2. Motorcycles in Group B1, B2 and B3 must be equipped with at least two brakes, operating independently, on at least two of the road wheels, each giving complete control.

8.3 TYRES

1. **Tyres for Hill climb and Twisty Sprint.** Any type of tyre is permissible.
2. **Tyres for Sprint.** There is no restriction on the type or size of tyres that may be used however the cross section must not be less than 50mm.

8.4 MUDGUARDS

Mudguards are not compulsory.

8.5 CLUTCH AND BRAKE LEVERS

Clutch and brake levers must be ball ended, the diameter of the ball being not less than 16mm and either an integral part of the lever or a permanent fixture.

8.6 PRIMARY AND AUXILIARY DEVICES

Adequate guards must be fitted to prevent the drives being accidentally touched at any part of the run not in contact with the sprockets.

8.7 THROTTLES

All machines must be fitted with self-closing throttles.

8.8 HANDLEBARS

1. Handlebar minimum width 450mm.
2. The minimum angle of rotation of the handlebars, each side of the centre line or mid-position must be 20 degrees.
3. Whatever the position of the handlebars, it must not be possible for the front wheel to make contact with any streamlining.
4. It is compulsory to fit a stop or stops or other devices to ensure a minimum clearance of 30mm between the handlebars and tank when on full lock to prevent the trapping of the rider's fingers.

8.9 SUPERCHARGERS

1. **Hill Climb** Superchargers are permitted.
2. **Sprint** The use of superchargers is permitted on machines up to 2000cc.

8.10 FUEL

1. Hill Climb and Twisty Sprint

1. Fuel may be Methanol or unleaded petrol, see ACU/FIM Fuel Regulations for physical properties, fuel test costs and penalties for non-compliance. Machines running on methanol must display an Orange sticker on the tank. (Test costs and penalties also apply if Methanol is used).
2. Power boosters nitrous oxide injection and octane boosters are forbidden.
3. Fuel must be stored in a labelled metal container.
4. Machines of a type manufactured before 1975 may use leaded pump petrol.

2. Sprint

1. Unless otherwise stated in the Supplementary Regulations, there shall be no restrictions as to the type of fuel that may be used.
2. All machines of any capacity running on any percentage of Nitro Methane must have a

positive fuel cut off that can be activated from the handlebars without the rider having to remove a hand from the handlebars and to display a red triangle on the front of the machine to indicate to the technical officials the machine is running on Nitro.

3. For Junior Classes only unleaded petrol may be used. Nitrous oxide injection, power and octane boosters are prohibited.

8.11 FOOTRESTS

1. The footrests for the rider must be positioned to give easy access to any control pedal.
2. The ends of the footrests must be rounded with a ball end of not less than 8mm diameter.

8.12 OIL DRAIN pLUGS AND SUPPLY pIPES

All oil drain plugs must be tight and must be drilled and wired in position. Oil supply pipes must be adequately wired in position.

8.13 OIL CATCH TANKS

1. Where an oil breather pipe is fitted the outlet must discharge into a catch tank located in an easily accessible position and which must be emptied before the start of a meeting.
2. Total loss engines must have an effective means of collecting all ejected oil with no discharge to road.

8.14 NUMBER pLATES

1. Whenever number plates are required to be carried at an event they will be three in number and must comply with the following requirements.
2. They must be made of rigid material and solidly constructed, rectangular in shape, measuring a minimum of 235mm × 285mm in size with 50mm radius rounded corners.
3. The plates must be flat or slightly curved (not more than one inch from the true plane) and must not be otherwise bent or obscured in any way.
4. One plate must be carried facing forward and not more than 25 degrees from the vertical and others must be facing outwards and vertical, one on each side of the machine.
5. The minimum dimension of the figures must be: height 140mm, width of stroke 25mm, and the space between any two figures 25mm.
6. The figures must be legible and both figures and background must be in a 'matt' (non-shiny) colour.
7. They must be so fixed that they are clearly visible and not obscured by any part of the machine or by the rider when he is in the riding position.
8. In place of detachable plates similar areas may be painted on the body of the machine or on the streamlining.
9. Any other number plate or any marking on the motorcycle that might be confused with a number plate must be removed before the rider is allowed to start. The following colours shall be used and they must be Matt colours following the RAL Colour table:
 Black 9005, Blue 5010, Yellow 1003, Orange 2007,
 Red 3020, Green 6002, White 9010

The front and side number plates for each class of motorcycles are:

Class	Background	Numbers
Up to 125cc	Black background	White numbers
Up to 250cc	Green background	White numbers
Up to 350cc	Blue background	White numbers
Up to 500cc	Yellow background	Black numbers
Up to 750cc	White background	Black numbers

Up to 1300cc	Red background	White numbers
Up to 2000cc	White background	Red numbers
Sidecars and Threewheelers	White background	Black numbers

8.15 CONTROL OF EXHAUST SOUND LEVEL

1. The Clerk of the Course may disqualify any machine which exceeds the maximum permitted sound level, or which in his opinion is deemed to be excessively noisy.
2. The sound level of hill climb machines is controlled according to the ACU method.
3. Machines must comply with the Supplementary Regulations for the meeting.

8.16 EXHAUST pIpES

For Hill climb and Twisty Sprint the end of the exhaust pipe or pipes may not project beyond any part of the vehicle or its bodywork. For straight line sprint machines any such projection will be at the discretion of the Clerk of Course.

8.17 CONSTRUCTION

The use of titanium in the construction of the frame, the front forks, the handlebars, the swinging arm spindles and the wheel spindles is forbidden. For wheel spindles, the use of light alloy is also forbidden. The use of titanium alloy nuts and bolts is allowed.

8.18 STREAMLINING FOR SpRINT MACHINES

1. Unless otherwise stated in the Supplementary Regulations, there is no restriction on the type of streamlining of a motorcycle except that there must be a clearance of at least 50mm between the streamlining and the extremities of the handlebars or other form of steering device, including any attachments thereto, whatever the position of the handlebars.
2. Should the streamlining totally enclose the rider and/or passenger, a firewall must be installed between the engine and the rider and passenger and, in addition, a substantial roll bar must be securely fitted.
3. Any streamlining must be approved by the Technical Official and, unless so approved, the motorcycle must not be driven in any event or in practice thereof.

8.19 SpRINT ADDITIONAL SpECIFICATIONS FOR SOLO MACHINES 1300CC AND OVER

All motorcycles in or over 1300cc (Category) must comply with the following:

1. A positive on-off ignition cut-out switch must be fitted in an accessible position on the handlebar so as to be operated by a rider or marshal in an emergency.
2. All fuel lines from the main supply tanks must be fitted with easily accessible on and off control taps.
3. A final drive steel guard with a minimum thickness of 1.5mm steel or 3mm alloy gauge must be fitted to enclose the top run if a chain is used. If drive shafts are employed, restraining steel rings must encircle the shafts, one at each end.
4. A clutch guard of sufficient strength must be fitted to protect the rider and/or passenger in the event of clutch parts breaking up. If cruciform in shape, it is to be made of minimum 38mm wide 3mm steel. If a complete covering, minimum 1.5mm wall thickness.
5. All frames must be entirely self-supporting and stable in the event of one or more of the engines disintegrating.
6. The front steering assembly must have a minimum trail of 100mm and be of sufficient strength to obviate any likelihood of collapse during acceleration or under braking conditions. Flimsy forks or frames are not permitted.
7. For Junior Classes superchargers and turbochargers are not permitted. For Junior Classes standard rebore are permitted to a maximum increase in engine capacity of 3cc.

8.20 HILL CLIMB AND TWISTY SPRINT – ADDITIONAL SPECIFICATIONS FOR THREE WHEEL MACHINES

1. Class 1

1. Handlebar steering – handlebar minimum width 450mm.
2. Handlebar twist grip.
3. Single front wheel steering only.
4. Or be age related, historic three wheel machines.

Class 2

1. Modern three wheel car type machines.
2. Steering wheel.
3. Accelerator pedal.
2. All fully enclosed streamlined three-wheelers must carry a timing strut mounted on the most forward part of the vehicle to activate timing devices in events where timing is activated by a light beam.
3. The vertical strut must be opaque and non-reflecting and a height of 25.4cm by a depth of 5cm between 20cm and 46cm from the ground.
4. A passenger must be carried in addition to the rider. The passenger must always be completely protected from the road wheels and drive (both primary and final) either by mud guarding or some other means.

8.21 SPRINT – ADDITIONAL SPECIFICATIONS FOR THREE-WHEELERS

1. All fully enclosed streamlined three-wheelers must carry a timing strut mounted on the most forward part of the vehicle to activate timing devices in events where timing is activated by a light beam.
2. Where fitted the vertical strut must be opaque and non-reflecting and a height of 25.4cm by a depth of 5cm between 20cm and 46cm from the ground.
3. A passenger or ballast must be carried in addition to the rider. If a passenger is replaced by ballast this must weigh not less than 132lb (60kg). The Ballast must consist of a single object securely fixed to the chassis/frame in the passenger seating area. It must be attached under the supervision of a Technical Official at the meeting. Where a passenger is carried, the passenger must always be completely protected from the road wheels and drive (both primary and final) either by mud guarding or some other means

SECTION 9 PROTECTIVE CLOTHING

9.1 pROTECTIVE CLOTHING

The rider must wear his protective clothing to Technical Control to demonstrate good fit.

1. Bulky hard objects such as tools etc. are NOT to be carried in pockets or on the person.
2. During practice and racing, riders and passengers must wear the following clothing and footwear:
3. Competitors must wear a complete leather suit of at least 1.2mm in thickness (on all parts of the suit), two piece suits that zip together at the waist are acceptable. Each part of the zip should be securely attached to the jacket or the trousers respectively and the suit must zip together over at least 75% of the waist band.
4. Non-leather material may be used if it meets with the requirements laid down by ACU Road Racing Standing Regulations.
5. Competitors footwear must be of leather (i.e. outer hide) or an approved substitute material and of a minimum height of 200mm to provide, with the suit, complete protection i.e. no exposed areas. No areas of skin to be left exposed between the wrist of the suit and the wrist of the glove.
6. Competitors must wear leather (or an approved substitute material) protective gloves to

provide, with the suit, complete protection. No areas of skin to be left exposed between the wrist of the suit and the wrist of the glove.

7. Long hair and beards should be contained within the helmet or clothing.

9.2 BODY JEWELLERY

It is recommended that any body piercing studs, ring etc. are removed.

9.3 HELMETS

1. Helmets bearing the current ACU gold stamp and in sound condition and properly fitted must be worn by all riders and passengers while practicing and racing.
2. Overseas riders may use helmets as approved by their own FMN.

9.4 IDENTIFICATION DISCS

While practising and racing, riders and passengers are required to wear an identification disc around the neck, attached by a material approved by the technical officer. Thin chains should be avoided. The disc must be permanently marked with the wearer's full name and date of birth. Identification discs shall be of a durable material, circular in shape, between 20mm and 25mm in diameter and having rounded edges with no sharp or ragged projections.

SECTION 10 RUN WHAT YOU BRUNG – CLASSES FOR ROAD LEGAL MACHINES

The National Sporting Code of the ACU, these Standing Regulations and the Disciplinary Section of the Road Race Standing Regulations shall apply to all Hill Climb, Sprint and Twisty Sprint "Run what you Brung" events within a Hill Climb, Sprint, or Twisty Sprint Meeting together with the Supplementary Regulations and any final instructions.

10.1 DEFINITION

A race at a Hill Climb Sprint, or Twisty Sprint meeting for Competitors competing on motorcycles registered and licensed for use on the Public Highway.

10.2 ELIGIBILITY

Open to competitors who are holders of a full DVLA motorcycle licence and who hold an ACU Competition Licence or ACU One Event Licence.

10.3 MACHINE ELIGIBILITY

Any motorcycle registered and licensed for use on the Public Highway. A current MOT certificate, if required, must be produced at Technical Control inspection. The machine must be in road legal condition to be eligible to take part in this type of event.

10.4 TECHNICAL CONTROL

1. The machine must be free from all obvious fluid leaks.
2. A number issued by the organisers must be displayed on the machine, to enable identification.
3. All lights and indicators must be taped over.
4. All stands must be wired or taped up.

10.5 PROTECTIVE CLOTHING

See Section 9.

SECTION 11 ACU SPRINT CHAMPIONSHIP QUALIFYING ROUNDS (TO BE ANNOUNCED)

11.1 TITLE

The main title of each round shall be the ACU Sprint Championship 'X' Round – this to appear on all documentation. The title may however be abbreviated at the discretion of the ACU in the case of the use of associated advertising material, where it would be impracticable to use the full title.

11.2 ELIGIBILITY

1. Open only to holders of a current ACU, Scottish ACU or MCUI competition licence for sprinting.
2. All Championship rounds shall be run under Restricted Permits.
3. All riders taking part in the championship must display an ACU decal on their machine these, will be provided by the event organiser at signing on, any competitor not complying will be disqualified from the results for that event

11.3 CLASSES

1. The ACU Championship will include three classes which will be based on capacity only.
 1. Machines up to and including 750cc
 2. Machines from 751cc to 1000cc
 3. Machines from 1001cc to 2000cc
2. Minimum Class Entries
 1. A Rider can enter more than one class but can only enter one bike per class.
 2. Insufficient entries of less than 3 riders/bikes for a class will result in the class being merged with the next higher class.
 3. If the class with insufficient entries is the unlimited capacity class then that class is dropped for that round.
 4. The rider will score points in the higher class that he has been merged into.
 5. No points will be allocated to the rider for the class that had insufficient entries.

11.4 POINTS

1. Points will be awarded for each round. 10 points 1st place, 8 points 2nd place, 6 points 3rd place, 5 points 4th place, 4 points 5th place 3 points 6th place, 2 point 7th place. 1 point for 8th place
2. There will be 3 extra points for a rider breaking his entered ACU Championship class track record or 4 points for a rider hitting his index for the ACU Championship class he has entered.
3. Each rider will be awarded 2 points for each ACU Championship round that they sign on for.
4. There will be nine rounds with 7 to count for the ACU Championship, if a rider does all 9 rounds he will drop his lowest 2 results.

11.5 OVERALL CLASSIFICATION

At the conclusion of the Championship the points for each rider's best seven performances from the nine rounds will be added together; the rider with the highest number of points overall in any one class will be declared the winner.

11.6 TIES

Ties will be decided as follows:

1. By the rider gaining the highest number of wins from the seven meetings counting for the riders total.
2. By the highest number of class records broken or highest number of perfect indexes attained.
3. By the greatest number of first and second places in all qualifying events.
4. In the event of a continuing tie, the decision will be taken on the basis of the highest speed recorded in either breaking the record or hitting the perfect index.

11.7 RESULTS RETURN METHOD

1. Immediately after each meeting organisers should send a copy of the result sheets to the Series Coordinator:
Mr. Neill Curtiss, 2 Durham Close, Cheltenham GL51 3DF2 Tel: 01242 573329 Mon to Fri.
2. The Series Coordinator will assess the results, and will send them immediately after the final round to the ACU for ratification. The Results form will be completed by him in the following manner:
 1. Heading: The number of the round, the venue and the date.
 2. Name: Rider's name.
 3. Number: Racing number allocated by round organiser.
 4. Record Time: If a new ACU Championship class track record has been established the time will be entered, otherwise a line will be drawn through the box.
 5. Class: Each rider's capacity class will be shown as appropriate.
 6. Position: Showing the results for each rider for every round, their best results in each class, points scored per round, records broken, or perfect Index scored, signing on points, total championship points, championship position.

11.8 TECHNICAL SPECIFICATION

These are as per Hillclimb and Sprint Section 8 Technical Specifications, these should be read by all competitors competing in the championship

11.9 PROTECTIVE CLOTHING

As per Hillclimb and Sprint Section 9 Protective Clothing of the ACU handbook.

SECTION 12 SPRINT RECORD ATTEMPTS

1. An application for a National Record Attempt meeting must be lodged with the ACU at least one month (International 3 months) before the attempt, together with the names of the appointed Timekeeper and Measurer.
2. Applications for a permit to attempt records by a rider must be received at the ACU offices not less than 28 days before the published day of the event.
3. Regulations governing attempts at British National Records and Elvington' Production Records are obtainable from the ACU Headquarters together with a list of current Records. Price £5.00 available from the ACU Road Race Department.

Pocket Bike

Standing Regulations

SECTION 1 GENERAL

1.1	Eligibility	369
-----	-------------	-----

SECTION 2 CLOTHING

2.1	Protective Clothing	369
2.2	Jewellery	370
2.3	Helmets	370
2.4	Identification Discs	370

SECTION 3 SOLO SPECIFICATIONS

3.1	Mini/Midi moto (Pocket Bike) Basic Dimensions in millimetres	370
3.2	Carburettors	370
3.3	Spark Plugs	371
3.4	Fuel	371
3.5	Kill Switch	371
3.6	Coolant	371
3.7	Oil and Coolant Containment	371
3.8	Wheels	371
3.9	Tyres	371
3.10	Brakes	371
3.11	Transmission	371
3.12	Exhaust	371
3.13	Noise Control	372
3.14	Bodywork	372
3.15	Number Plates	372

SECTION 4 MINIF1 SIDECAR

4.1	Passenger	372
4.2	Construction	372
4.3	Basic Dimensions	372
4.4	Wheels	372
4.5	Sidecar Wheel	372
4.6	Tyres	373
4.7	Brakes	373
4.8	Engines	373
4.9	Engine Position	373
4.10	Oil and Coolant Containment	373
4.11	Kill Switch	373
4.12	Air Intakes	374
4.13	Fuel	374
4.14	Coolant	374
4.15	Fairings/Bodywork	374
4.16	Number Plates	374

SECTION 5 MEDICAL SERVICES 374**SECTION 6 ACU MINI BIKE CHAMPIONSHIP** 375

The National Sporting Code of the ACU and these Standing Regulations shall apply to all Minimotos, MiniGP, Pitbikes, and MiniF1 Sidecars Meetings, together with the Supplementary Regulations and any final instructions.

Definition A sport where Minimotos, MiniGP, Pitbikes, and MiniF1 Sidecars propelled by single or multi speed internal combustion engines compete in massed start races around a specially designed metallated road circuit.

SECTION 1 GENERAL

1.1 ELIGIBILITY

- Race Circuits** These can be either permanent or temporary courses. The Circuit must be suitable for Mini Bike racing, typically Pro Kart circuits or a shorter motorcycle race circuit. The circuit should ideally have a minimum length of 800 metres and minimum width of 6 metres.
- Competitors** All competitors must hold a current competition licence for Road Racing or Pocket Bike Racing issued by the Auto Cycle Union.
- Categories**

Class	Machine	Age Limits Years
AC40R (Rookie)	40cc Air Cooled 2-Stroke (exhaust restrictor as per regulations)	6 to 11
AC40PRO	40cc Air Cooled 2-Stroke (exhaust restrictor as per regulations)	6 to 13
Junior LC40	40cc Liquid Cooled 2-Stroke	7 to 13
Senior AC40	40cc Air Cooled 2-Stroke or 110cc 4-Stroke	14 & over
Senior LC40	40cc Liquid Cooled 2-Stroke or 110cc 4-Stroke	14 & over
SUPER	50cc Liquid Cooled 2-Stroke	14 & over
MiniGP50 MK	50cc Liquid Cooled 2-Stroke – 6 speed gearbox	9 to 15 (note 1)
MiniGP70 MK	70cc Liquid Cooled 2-Stroke – 6 speed gearbox	11 to 16 (note 2)
PB140	Up to 140cc 4-Stroke Pitbike – 4 speed gearbox	16 & over (note 3)
PB-Open	Up to 200cc 4-Stroke or 90cc 2-Stroke – 4 to 6 speed gearbox	16 & over (note 3)
MiniF1 Sidecars		Driver 18 & over Passenger 16 & over

Notes

- From 8 years with good experience on Minimotos.
- From 10 years with good experience on MiniGP50.
- Younger riders with geared bike experience or ACU Race Licence will be considered to ride. FIME Mini Road Racing Championship. Junior riders wishing to compete in the FIME Mini Road Racing Championship, or any other mini road race abroad, will be assessed individually based on their own proven ability.

SECTION 2 CLOTHING

2.1 PROTECTIVE CLOTHING

Protective Clothing: Minimoto (Pocket Bike), MiniGP/Pitbike, MiniF1Sidecars.

1. Protective Clothing: Minimoto (Pocket Bike)

One piece leather race suits or proprietary Minimoto (Pocket Bike) race suits are acceptable for Junior riders. A back protector must be included in the suit or worn separately. Adult riders must use either a one piece leather race suit or can use a two piece leather suit that fully zips together at the waist. A back protector must be built into the suit or worn separately.

2. Protective Clothing: MiniGP/Pitbike

One piece leather race suits. A back protector must be included in the suit or worn separately. Adult riders must use either a one-piece leather race suit or a two-piece leather suit that fully zips together at the waist.

3. MiniF1 Sidecars

All competitors must wear a helmet as described in Road Race Technical Regulations. Driver and passenger must wear an all in one leather race suit. Two piece leather suits can be permitted if they are fully zipped together. Back protectors must be worn.

4. Race Boots

Must be leather and have good ankle protection. There must be no gap between the top of the boots and the bottom of race suit when in a riding position. Leather must be worn. Trainers/ trainer boots will NOT be allowed.

2.2 JEWELLERY

It is recommended that all body piercing, studs, rings etc. are removed.

Competitors are advised not to wear hand, face or body jewellery/piercings which could prove hazardous in the event of an accident. The mouth should be kept clear of anything likely to cause a blockage of the airway in the event of an incident, e.g. chewing gum. This includes removing dentures.

2.3 HELMETS

All competitors must wear a helmet as described in Road Race Technical Regulations.

2.4 IDENTIFICATION DISCS

While practising and racing riders and passengers are required to wear an identification disc around the neck, attached by a material approved by the technical official. Thin chains should be avoided. The disc must be permanently marked with the wearer's full name and date of birth. Identification discs shall be of durable material, circular in shape, between 20mm and 25mm in diameter and having rounded edges with no sharp or ragged projections.

SECTION 3 SOLO SPECIFICATIONS**3.1 MINI/MIDI MOTO (POCKET BIKE) BASIC DIMENSIONS IN MILLIMETRES**

Wheelbase 730mm maximum

Length 1060mm

maximum Saddle Height 450mm

maximum Total Height 620mm

maximum

Footrests Non Folding 60mm minimum Plastic or Rubber – Round

Tipped A tolerance of 5% is allowed.

Minimotos must have dry centrifugal clutch keyed into the crank shaft. The engine for solo machines must have a recoil cord pull starting device.

3.2 CARBURETTORS

- 1. Junior Minimoto AC40** Rookie and Junior LC40 (Production) Class – Dellorto Standard SHA 14/14L or 15mm with any jet. This may be mounted on a rubber manifold.
- 2. Senior Minimoto AC40, LC40 and SUPER** Classes. No restrictions.
- 3. MiniGP50** Dellorto SHBG 19mm – Main jet, pilot jet, slide, and slide needle, may be changed.
- 4. MiniGP70** MRD or BRK 28mm – Main jet, pilot jet, slide, and slide needle, may be changed.
- 5. PB140 Pitbike** Maximum 26mm.
- 6. PB-Open** No Restriction.

3.3 SpARK pLUGS

No restrictions but must be "R" (resistor) type to prevent interference with transponders used for timing.

3.4 FUEL

Only unleaded fuel, that can be obtained from a roadside petrol station can be used.

3.5 KILL SWITCH

A kill switch must be located on the handlebars adjacent to the headstock.

3.6 COOLANT

Water with no additives is the only coolant permitted in water cooled (LC) engines.

3.7 OIL AND COOLANT CONTAINMENT

1. All 4 stroke machines must have a metal catch tank mounted directly below the engine or, for machines fitted with a full fairing, a catchment "tray" constructed in the lower cowling to hold at least 1.5 times the volume of the engine oil capacity.
2. Oil lines containing positive pressure must, if replaced, be metal or metal reinforced construction, with swaged or threaded connectors.
3. Any oil, fuel, or, coolant, breather pipes must discharge into a catch tank in an easily accessible position. Must be empty before the start of the meeting, minimum capacity 500ml.
4. ALL machines, 2 and 4 stroke must have drilled and wire locked oil drain and oil filler plugs.

3.8 WHEELS

1. **Minimotos** Any make of wheel is permitted. The diameter of wheel and tyre is 6.5ins maximum. The width of the wheels is 110mm maximum.
2. **MiniGP** Standard 12ins MK wheels.
3. **PB140** Any make of 10ins or 12ins wheel.
4. **PB-Open** Any make of wheel 10ins to 17ins.

3.9 TYRES

1. **Minimotos** Any make of 6.5ins tyre, slick or treaded, is permitted unless otherwise specified.
2. **MiniGP** EC Homologated 12ins tyres restricted. Make as per event supplementary regulations.
3. **PB140** Any make of 10ins or 12ins tyre, slick or treaded unless otherwise restricted.
4. **PB-Open** Any make of 10ins to 17ins tyre, slick or treaded unless otherwise restricted.

3.10 BRAKES

Cable or hydraulic operated disc brakes are required on front and rear wheels.

3.11 TRANSMISSION

By chain with any ratios. A chain guard must be fitted in such a way as to prevent trapping between the lower chain run and the final driven sprocket at the rear wheel.

3.12 EXHAUST

1. **Minimoto AC40R (Rookie)**: Standard or aftermarket exhaust supplied for the make and model. Must be one piece back to the silencer connection. A 10mm restrictor of a type approved by the class organiser to be fitted directly between the cylinder and exhaust pipe. Supplementary regulations may also require a seal being fitted to the restrictor. Organisers MAY, if considered necessary, specify a variation in the size of the restrictor to allow for power differences in some older models.

- 2 **Minimoto AC40PRO (Production):** As per AC40R except that the restrictor will be 14mm. No size variation permitted.
- 3 **Minimoto LC40:** Any exhaust permitted except "SUPER" pipes.

3.13 NOISE CONTROL

Maximum permitted level will be as specified by the circuit used. In general this will be 98dba measured at a specific location on the circuit.

3.14 BODYWORK

- 1 **Minimotos** Fairing and streamlining are permitted. Covering of the headstock is compulsory.
- 2 **MiniGP** Must use full fairing as per original supply by MK. Copies of all original body work permitted in GRP (fibreglass) only.
- 3 **PB140** Full fairings not permitted.
- 4 **PB-Open** Full fairings not permitted.

3.15 NUMBER PLATES

- 1 Front numbers are compulsory and must be minimum 70mm high. They must be of a contrasting single colour to the number plate (e.g. white numbers on a black plate).
- 2 Side number plates should be used where possible to aid timekeepers, spectators and film crews.
- 3 The font for all numbers must be in accordance with the ACU Road Race Standing Regulations.

SECTION 4 MINIF1 SIDECAR

4.1 PASSENGER

A passenger must be carried and must always be protected from the road wheels and both primary and final drive trains.

4.2 CONSTRUCTION

Suspension is not permitted. The chassis must be of good quality steel or aluminium (6082 grade or higher) tube with a maximum external diameter of 2 inches (50.8mm) or box with a maximum dimension of 2 inches measured at 90 degrees to any edge. Metal parts of the chassis must not come in contact with the road surface during normal racing. The non-metallic frame protectors and or crash bobbins should be fitted to areas of the chassis where this might occur. Any fixings must be sunken into the protectors or bobbins.

4.3 BASIC DIMENSIONS

Maximum overall length (including bodywork)	1727m
m Maximum overall width (including bodywork)	1122m
m Maximum overall height (including bodywork)	616mm
Maximum wheelbase	1144m
m	
Maximum track	759mm

(The track is measured from the centre of the track left by the rear wheel to the centre of the track left by the sidecar wheel).

4.4 WHEELS

Must be of metal construction with a maximum diameter of 6 ins.

4.5 SIDECAR WHEEL

The sidecar wheel must be offset to the left of the driver with the sidecar axle forward of the rear wheel axle. This wheel must not steer, steering must be operated through the front wheel only.

4.6 TYRES

Any make of tyre, slick or treaded, is permitted. Kart tyres are permitted.

4.7 BRAKES

All sidecar outfits must have two independent braking systems. One system operating on the front wheel and the other on the rear wheel. At least one of these systems must be of the hydraulic type. A sidecar wheel brake is optional.

4.8 ENGINES

1. Single cylinder 2-stroke road derived petrol motorcycle or scooter engine with a maximum capacity of 86cc. Tuning allowed to a maximum of 26bhp.
OR
Single cylinder 4-stroke road derived petrol motorcycle or scooter engine with a maximum capacity of 200cc. Tuning allowed to a maximum of 26bhp.
OR
Single cylinder 2-stroke moto-cross engine to a maximum capacity of 85cc (maximum 26bhp). Tuning not permitted. Engine, gearbox, carburettor, ignition and induction system to remain as manufacturer's standard. The use of aftermarket reeds (petals) is permitted. Exhaust may be an after market type designed to fit your engine and must be readily available to any member of the public to buy.
OR
Single cylinder 4 stroke moto-cross engines to a maximum capacity of 150cc (maximum 26bhp).
Tuning is not permitted. Engine, gearbox, cam shaft, carburettor, ignition to remain as manufacturer's standard. The use of high compression pistons is not permitted. Exhaust may be an after market type designed to fit the engine and must be readily available to any member of the public to buy.
2. Transmission Maximum 6 speed gearbox.

4.9 ENGINE POSITION

The engine may be positioned anywhere between the front and rear wheel. The drive must be transmitted through the rear wheel only.

4.10 OIL AND COOLANT CONTAINMENT

1. In the area directly below the engine, the oil containment tray must be constructed to hold, in case of an engine breakdown, at least half of the total oil and engine coolant capacity used in the engine (minimum 5 litres).
2. The surrounding edges of the tray must be at least 50mm above the bottom of the tray.
3. ALL Four stroke machines must use this tray.
4. Oil lines containing positive pressure must, if replaced, be of a metal construction, with swaged or threaded connectors.
5. Oil coolers must not be mounted on or above the body of the sidecar.
6. The location of the oil tank and oil cooler should not be placed in a location likely to be damaged in an accident.
7. Any oil breather pipes must discharge into a catch tank in an easily accessible position. Must be empty before the start of the meeting, minimum capacity 500ml.

4.11 KILL SWITCH

A lanyard type ignition cut-out must be fitted to kill the engine when the driver leaves the machine. The cut-out must be placed as near to the centre of the handlebars as possible and must be operated by a non-elastic cord or spiral cable of adequate length and thickness. It must have a maximum extended

length of 1 metre and be securely attached to the driver's body. Any electrically operated fuel pumps must be wired in such a way as to cut out if the engine kill device is operated.

4.12 AIR INTAKES

Air or cooling ducts must not project outside the maximum allowable length, width or height of the outfit.

4.13 FUEL

Only unleaded fuel that can be obtained from a roadside petrol station may be used. Race fuels are not permitted.

4.14 COOLANT

Water only no additives may be used.

4.15 FAIRINGS/BODYWORK

All sidecars are required to have a full front fairing. The sidecar wheel must be enclosed from the sidecar platform, level with the platform on the outside and right around the periphery. A cut out to check the tyre pressure is permitted. The bodywork, fairing and sidecar wheel arch (and seat unit if applicable) must be constructed of GRP (fibreglass) or similar. All exposed edges must be rounded. Whatever the position of the handlebars there must be a space of at least 20mm between the fairing and the ends of the handlebars and/or control levers. Ball ended handlebar control levers must be used. The wheels and tyres must not foul any bodywork. All passenger handholds must be rigid and of the closed loop type. All fairings and bodywork must be easily removable for technical inspection scrutineering if required.

4.16 NUMBER PLATES

Front numbers are compulsory and must be 70mm high. They must be of a contrasting colour to the number plate (e.g. white numbers on a black plate). The font for all numbers must be in accordance with the ACU Road Race Standing Regulations. Side numbers should also be used where possible to aid both timekeepers and film crew.

SECTION 5 MEDICAL SERVICES

5.1 MEDICAL SERVICES. MINIMUM REQUIREMENTS FOR POCKET BIKE MEETINGS

The minimum requirements for practice or racing to commence are as follows:

1 Doctor and 1 Paramedic or 2 Paramedics, 1 Rapid Response Vehicle, 1 Ambulance.

If one Ambulance has to leave the venue for any reason, the event can continue provided that there are a minimum of 1 ambulance and 2 Paramedics present and available.

Whenever possible a First Aid Technician and a second Ambulance should be made available.

Ambulance A vehicle registered as an ambulance with the DVLA (Driver and Vehicle Licensing Agency) and registered with GQC if appropriate.

An ambulance must have an appropriately qualified driver to transport a casualty under blue lights. It must be equipped with the FIM minimum equipment regulations for a type C vehicle; that is: Medical: A stretcher (preferably standardised), oxygen supply, apparatus to immobilise limbs and vertebral column. First aid medicaments and materials.

Technical: Radio communication. Visible and audible signals.

Staffing: An ambulance must be staffed by two First Aid Personnel (who can be the two minimum First Aid Personnel).

An ambulance may act as a Medical Centre BUT if so it must be a vehicle in addition to the minimum ambulance requirements and must not be allowed to leave the circuit.

First Aid Personnel A person holding a current certificate of First Aid competency. (Where an event

is open to the public event organisers should ensure that all First Aid personnel are insured against malpractice for the event concerned).

Special Notes

The minimum medical requirements specific for this discipline also apply to associated Test Days.

Concussion/suspected concussion

If a competitor is involved in an incident which results in him being diagnosed by the Medical Officer/Paramedic as suffering from concussion/suspected concussion, the rider is not permitted to participate any further in that event.

Organisers are to notify ACU Head Office as soon as possible of any concussion/suspected concussion injuries and then will subsequently:

- a) Place the rider on the ACU Stop List
- b) Inform Organisers of forthcoming events that the Rider has suffered a concussion/suspected concussion injury and is therefore placed on the ACU Stop List
- c) Inform the Rider that he needs to see a Doctor and obtain a letter/doctor's certificate which confirms he is fit to resume competitive racing/participate in a practice/test session.

The recovery time for anyone diagnosed with concussion/suspected concussion is as follows:

- a) Over 20 years: Excluded immediately and suspended for a period of nine days.
- b) 16–19 years: Excluded immediately and suspended for a period of twelve days.
- c) 15 and under: Excluded immediately and suspended for a period of twenty three days.

The rider is not permitted to ride during the obligatory suspended periods outlined above and then only once he is in possession of a doctor's certificate/letter after the suspended period has expired. A rider may be signed off to ride by the CMO at an event once he has observed the obligatory suspended period outlined above.

If a competitor has been injured on a Saturday and is suffering from concussion/suspected concussion, and the Organiser is aware that the rider was intending to ride or is scheduled to ride somewhere else the next day, the Organiser will inform the Organiser of the event being held the next day so they are aware of the rider's injuries and as such he is prevented from participating in that event.

SECTION 6 ACU MINI BIKE CHAMPIONSHIP

The National Sporting Code of the ACU, the Pocket Bike Standing Regulations together with these Mini Bike Championship Conditions and the Disciplinary Section of the Road Race Standing Regulations shall apply to all rounds of the ACU Mini Bike Championship together with the Supplementary Regulations and any final instructions

6.1 CHAMPIONSHIP STATUS

The Championship will be held under the auspices of the ACU Ltd.

6.2 CHAMPIONSHIP ROUNDS AND VENUES

There will be 6 two day events between March and October.

6.3 CIRCUITS

The circuit should be inspected and approved by the ACU Track Inspector. The circuit licence will be valid for a period of three years. The minimum width should be 6 metres. The minimum length should be 500 with the maximum length to be set at the track inspection.

6.4 GRID AND STARTING NUMBERS

The grid should be set out during the track inspection, but should in principle be a 3 × 3 solo grid with 6 metres between each row. In principle the grid capacity should be a maximum of 28 machines with a 50% additional allowance for qualifying or practice unless the ACU Track Inspector sets a lower limit during the inspection.

6.5 pRACTICE AND qUALIFYING

There will be a minimum of 15 minutes practice/qualifying allocated to each class at each event. Participation in these sessions is compulsory for a minimum of 3 laps. On the 2nd day of a two day meeting a minimum of 10 minutes practice must be made available to every competitor. Participation in the 2nd days free practice is not compulsory. Testing or practice at the same venue is prohibited for the 72 hours preceding each championship round.

Each grid will be set based on lap times recorded during each qualifying practice.

6.6 CHAMpIONSHIp LICENCE

An ACU Mini-Bike Championship Licence will be required in order to take part in the series.

This will be available for a fee of £10 from the ACU and will only be valid for participation in this championship. An eyesight report is not required for this licence, but the Clerk of the Course or Chief Medical Officer may require any competitor at random to submit an eyesight test before competing. Any competitor holding an ACU Road Race or Supermoto Licence may add Mini Bike Championship eligibility with no extra charge.

6.7 COMpETITOR TRAINING

As this is an entry level to tarmac racing, no previous competition experience is required, but every competitor must attend a riders briefing and induction course before participation in their first event. Once the induction course has been received, a validation sticker will be added to the back of the competitor's ACU Licence.

6.8 CHAMpIONSHIp pOINTS

Points will be awarded for each championship race on the scale 25.20.16.13.11.10.9.8.7.6.5.4.3.2.1. If at the end of the season, there is a tie on the points then the highest number of wins will determine the winner, should that be equal then the 2nds, 3rds, etc will be taken into account until a winner is established.

Scooter

Standing Regulations

SECTION 1 MEETINGS

1.1	Categories of Meetings	382
1.2	International	382
1.3	European Open	382
1.4	National	382
1.5	Open	382
1.6	Restricted	382
1.7	Eligibility of Foreign Riders in Open and Restricted Meetings	383
1.8	Practice Meetings and Test Days	383
1.9	Conditions for Road Race Meetings	383
1.10	Force Majeure	383

SECTION 2 LICENCE – COMPETITORS

2.1	General	383
2.2	Grades	383
2.3	Lapsed Licences	384
2.4	Capacity and Licence Restrictions	384

SECTION 3 LICENCES AND REGISTRATIONS – OFFICIALS

3.1	Qualifications and Conditions	384
3.2	Road Race Officials who Require a Licence	384
3.3	Grades for Clerk of the Course	384
3.4	Road Race Officials who do not Require a Licence	385

SECTION 4 PRACTICE

4.1	Practice sessions	386
-----	-------------------	-----

SECTION 5 GRID POSITIONS

5.1	Positions	386
5.2	Timed Practice	386
5.3	Balloted	386
5.4	Allocated	386

SECTION 6 START PROCEDURES

6.1	Group Starts	387
6.2	Interval Starts	387
6.3	Clubmans Races	387
6.4	National Races	387
6.5	Anticipation of the Start	388

SECTION 7 FLAGS AND LIGHTS

7.1	Flags and Lights Used to Provide Information	388
7.2	Flags Used to Convey Information and Instructions	389
7.3	Flag Dimensions	390
7.4	Flag Colours	391
7.5	Flag Marshals' Posts	391
7.6	Marshals' Overalls	391

SECTION 8 BEHAVIOUR DURING PRACTICE AND RACE

8.1	Riders must obey the flag signals, the light signals, and the boards	391
8.2	Protests	392

SECTION 9 NEUTRALISATION OF RACES – SAFETY CAR 392

SECTION 10 INTERRUPTION OF A RACE 393

SECTION 11 RE-STARTING A RACE THAT HAS BEEN INTERRUPTED 394

SECTION 12 FINISH OF A RACE AND RACE RESULTS

- 12.1 Finish of a Race 395
- 12.2 The Chequered Flag will Continue to be Displayed to the Subsequent Riders. 395
- 12.3 Race Results 395

SECTION 13 SAFETY

- 13.1 Medical Services – Minimum Requirements for Road Race Meetings 396
- 13.2 Track Safety Precautions 397
- 13.3 Fire Extinguishers 398
- 13.4 Fire Extinguishers at Circuits 398
- 13.5 Warning and Prohibition Signs at Circuits 398
- 13.6 Declaration – Admission Tickets, Armbands and Passes 399
- 13.7 Declaration on the Official Programme 399
- 13.8 Signing On 399

SECTION 14 GENERAL SPECIFICATIONS

- 14.1 Protective Clothing 399
- 14.2 Helmets 400
- 14.3 Identification Discs 400
- 14.4 Body Jewellery 400

SECTION 15 GENERAL REGULATIONS FOR SOLO MOTOR SCOOTERS

- 15.1 Introduction 400
- 15.2 Terms & Definitions 400
- 15.3 General Regulations 401
- 15.4 Inclination 401
- 15.5 Engine Position 401
- 15.6 Composite or Monocoque Construction 401
- 15.7 Steering 401
- 15.8 Use of Titanium & Other Exotic Materials 402
- 15.9 Mirrors 402
- 15.10 Friction Linings, Disc Pads and Brake Hoses 402
- 15.11 Stand/Side Stand Mounting Lugs 402
- 15.12 Throttle Controls 402
- 15.13 Control Levers 402
- 15.14 Projections 402
- 15.15 Glass 402
- 15.16 Air Intakes 402
- 15.17 Fuel 402
- 15.18 Oil Drain/Filler Plugs and Catch Tanks 402
- 15.19 Electrical Systems and Battery 403
- 15.20 Exhausts 403

15.21	Liquid Cooling	403
15.22	Tyres	403
15.23	Compulsory Alterations	403

SECTION 16 TECHNICAL SPECIFICATIONS FOR MOTORSCOOTER SIDE CAR COMBINATIONS (GROUP 7)

16.1	Introduction	403
16.2	General	403
16.3	Construction	404
16.4	Dimensions	404
16.5	Streamlining and Bodywork	404
16.6	Projections	404
16.7	Drive Guard	405
16.8	Glass	405
16.9	Air Intakes	405
16.10	Engine and Drive Units	405
16.11	Engine Position	406
16.12	Induction Systems	406
16.13	Forced Induction	406
16.14	Fuel	406
16.15	Exhaust Systems	406
16.16	Fuel Tank	406
16.17	Oil Drain/Filler Plugs and Catch Tanks	406
16.18	Steering	406
16.19	Wheels and Tyres	407
16.20	Front Suspensions	408
16.21	Rear Suspension	408
16.22	Brakes	408
16.23	Mudguards and Wheel Protection	408
16.24	Driver	408
16.25	Passenger	408
16.26	Electrical Systems and Battery	408
16.27	Throttle Controls	408
16.28	Control Levers	408

SECTION 17 TECHNICAL SPECIFICATIONS FOR FORMULA 125 MOTORSCOOTER SIDE CAR COMBINATIONS

17.1	Construction	409
17.2	Dimensions	409
17.3	Streamlining and Bodywork	409
17.4	Driveguards	409
17.5	Engine and Drive Units	409
17.6	Engine Position	410
17.7	Induction Systems	410
17.8	Fuel - Unleaded	410
17.9	Steering	410
17.10	Wheels and Tyres	410
17.11	Rear Suspension	411

SECTION 18 TECHNICAL SPECIFICATIONS FOR CLASSIC (GROUP 8) MOTORSCOOTER SIDE CAR COMBINATIONS

18.1	Introduction	411
18.2	Construction	411
18.3	Dimensions	411
18.4	Streamlining and Bodywork	411

18.5	Engine and Drive Units	412
18.6	Crankcase	412
18.7	Crankshaft	412
18.8	Gearcase	412
18.9	Engine Position	413
18.10	Induction Systems	413
18.11	Wheels and Tyres	413
18.12	Rear Suspension	413
18.13	Control Levers	413

The National Sporting Code of the ACU and these Standing Regulations shall apply to all Scooter meetings, together with the Supplementary Regulations and any final instructions.

SECTION 1 MEETINGS

1.1 CATEGORIES OF MEETINGS

- International Meetings
- European Open Meetings
- National Meetings
- Open Meetings
- Restricted Meetings

Permits for all Road Race competitions are issued by ACU Headquarters

1.2 INTERNATIONAL

1. The Permit shall be issued by the ACU Headquarters for a meeting inscribed on the International Calendar of the FIM and having an FIM International Meeting Number (IMN).
2. An International meeting is open to Entrants and Riders of more than one nation who must hold an International Licence or a National Licence issued by the ACU valid for the particular meeting concerned.
3. All riders not holding a Licence issued by the ACU or SACU must carry proof of Insurance and a written Start Permission document issued by their FMN.

Note: This includes all riders holding a licence issued by the MCUI.

1.3 EUROPEAN OPEN

1. The permit shall be issued by ACU Headquarters for a meeting inscribed on the Calendar of the Fédération Internationale de Motocyclisme Europe (FIME) and having a European Meeting Number (EMN).
2. A European Open meeting is open to Entrants and Riders of more than one European nation who must hold the appropriate Competition Licence valid for the particular meeting concerned.
3. All riders not holding a Licence issued by the ACU or SACU must carry proof of Insurance and a written Start Permission document issued by their FMN.

Note: This includes all riders holding a licence issued by the MCUI.

1.4 NATIONAL

1. The Permit shall be issued by the ACU Headquarters.
2. A National meeting is open to Entrants and Riders who are the holders of a National or International Licence valid for the particular meeting concerned issued by any Federation.
3. All riders not holding a Licence issued by the ACU or SACU must carry proof of Insurance and a written Start Permission document issued by their FMN.

Note: This includes all riders holding a licence issued by the MCUI.

1.5 OPEN

1. An Open permit is issued by ACU Headquarters.
2. An Open meeting is open to Entrants and Riders who hold a valid ACU or SACU Licence for the meeting concerned.

1.6 RESTRICTED

1. A Restricted Permit is issued by ACU Headquarters.
2. A Restricted meeting is open to Entrants and Riders who hold a current ACU or SACU Licence valid for the meeting concerned.

3. The Supplementary Regulations issued for the event must specify all restrictions and requirements of eligibility.

1.7 ELIGIBILITY OF FOREIGN RIDERS IN OPEN AND RESTRICTED MEETINGS

1. The Supplementary Regulations issued for the event must specify the licence qualification and eligibility requirements of foreign riders.
2. All riders must have a current Licence and Start Permission from their own Federation valid for the event.

1.8 PRACTICE MEETINGS AND TEST DAYS

1. Permits for Practice Meetings and Test Days may be issued on application to the Permit Issuing Authority.
2. No such event may be held unless the appropriate Permit and Insurance has been issued.

1.9 CONDITIONS FOR ROAD RACE MEETINGS

1. The ACU Road Race Committee must approve the Organiser.
2. The Venue must hold a current Track Licence or Track Certificate issued by the ACU Road Race Committee.
3. The ACU Secretariat must approve the Supplementary Regulations for the event and issue an ACU Permit prior to publication and circulation.
4. For all ACU Championships an ACU decal, supplied by the ACU Secretariat, must be displayed on each machine. Any rider not complying will be disqualified from the results of the race.

1.10 FORCE MAJEURE

The Clerk of the Course has the right to alter, abandon, cancel or postpone all or any part of a meeting for reasons of force majeure. Such a decision shall not be subject to any protest.

SECTION 2 LICENCE – COMPETITORS

2.1 GENERAL

1. To participate in Scooter Road Race events an annual Licence issued by the ACU is required. Residents in Scotland apply to the Scottish ACU.
2. First time applicants are required to complete a classroom based ACU Competitor Training Course. Riders and Sidecar Drivers must also satisfactorily complete an ACU Basic Rider Assessment. Full details from the ACU Road Race Department.
3. A Licence can be upgraded at any time during the year.
4. The parent or legal guardian must accompany all competitors, or participants in parades, under 18 years of age to every meeting. This person must attend at signing-on and be present throughout the meeting.

2.2 GRADES

1. **Clubman** Entry level for all first-time Scooter Road Race Applicants.
2. **National Clubman** Competitors may apply to be upgraded to a National licence after competing at 10 separate race days at 3 different venues during the current year and preceding 2 years. The competitor record card together with copies of the official result sheets pertaining to the signatures on the record card should be submitted to the ACU Road Race Department. Only one signature per day of competition is permitted. National Licence holders may apply for Start Permission to compete abroad.

2.3 Lapsed LICENCES

Licence holders who have allowed their licence to lapse for more than 5 years will be required to complete the ACU Competitor Training Course, after which a Clubman licence may be issued.

2.4 CAPACITY AND LICENCE RESTRICTIONS

Up to 125cc Production automatic scooter	11yrs	Clubman Licence
Up to 125cc Production based scooter	12yrs	Clubman Licence
Unrestricted Scooter	14yrs	National Licence
Unrestricted Scooter	15yrs	Clubman Licence

SECTION 3 LICENCES AND REGISTRATIONS – OFFICIALS

3.1 QUALIFICATIONS AND CONDITIONS

Road Race Officials are divided into two categories: Those that are Licensed and those that are Registered.

Licences: Senior Road Race Officials are required to hold an ACU Licence of the appropriate Grade for the performance of their duties.

Registration: A Register is maintained of Officials not required to hold a Licence.

3.2 ROAD RACE OFFICIALS WHO REQUIRE A LICENCE

All the following licences are valid for 3 years.

	See Note Below	Attendance at Seminar/Training Session
Clerk of the Course	1	Every third year maximum
Chief Steward	2	Every third year maximum
Chief Technical Officer	3	Every third year maximum
Sound Inspector		Required for First Issue only
Measurer	4	Required for First Issue only
Timekeeper	5	Equipment and operators check

Clubs and Centres shall only nominate candidates whose aptitude and integrity for the position they can fully justify. Official ACU approval and the issue of a Licence is only after the candidates have proved to be competent according to the special requirements for each discipline. The respective Committees and Panels organize Seminars that are compulsory for certain Officials.

3.3 GRADES FOR CLERK OF THE COURSE

- Probationary** Any club may nominate a Probationary Clerk of the Course. Such a Registered Official may act as an Assistant to a National C Clerk of the Course at a Closed to Club event. To upgrade from Probationary to National C a registered official must act as an Assistant at 10 meetings and be recommended by the Clerk of the Course and must be nominated by a club for a specific future event.
- National Grade C** A Clerk of the Course who may officiate at a Closed to Club event where the use of slick tyres has NOT been authorised. May act as Deputy or Assistant Clerk of the Course at National Restricted events and Closed to Club events where slick tyres have been authorised. To upgrade from National C to National B a licence holder must officiate as Clerk of the Course at 5 Closed to Club events. He must also officiate as a Deputy to a National B Clerk of the Course at 5 events and be recommended by the Clerk of the Course at each. In addition members of the Road Race, Drag and Sprint Committee may be appointed to observe him. A Club must nominate him as being required to take charge of a specific future event.
- National Grade B** A Clerk of the Course who may officiate at a National Restricted event or a

Closed to Club event where slick tyres HAVE been authorised. May officiate as Deputy to a National Grade A.

To upgrade from National B to National A a Licence holder must officiate as a National B Clerk of the Course at 5 events. He must act as Deputy to a National A Clerk of the Course at 5 events and be recommended by the Clerk of the Course at each. In addition members of the Road Race, Drag and Sprint Committee may be appointed to observe him. A club must nominate him as being required to take charge of a specific future event.

4. **National Grade A** A Clerk of the Course who may officiate at any event held under an ACU Permit. May officiate as Deputy or Assistant at FIM (Non Championship) event.

Note 1 Clerk of the Course

Age Limits: Licences for Clerks of the Course who have attained their 70th birthday will be reviewed annually. Officials will be required to satisfactorily attend a seminar annually. The issuing of a licence will be subject to Road Race Committee approval.

Note 2 Chief Steward

Grades: There is only one grade of Steward's Licence for all Road Race disciplines.

Age Limits: Stewards may not normally officiate beyond the end of the season in which they attain their 70th birthday. The Road Race, Drag and Sprint Committee will review Stewards who reach the age of 70 for appointments on an annual basis.

Note 3 Chief Technical Officer

The Chief Technical Officer will be licensed by the Technical Panel to be in charge of the Technical Control at an event. The Technical Panel may restrict the disciplines of licence holders.

Note 4 Measurer

The Measurer is required for ACU National Championships and National events. The Licence is issued by the Technical Panel and may be restricted by discipline.

Note 5 Timekeepers

Will be required to pay for their Licence.

Licence Fees: All licences (exception Timekeepers licences) will be issued, free of charge, for a period of three years. No fee will be charged for attendance at Seminars organised by the Road Race Drag and Sprint Committee or the relevant Panel with the exception of FIM Seminars.

3.4 ROAD RACE OFFICIALS WHO DO NOT REQUIRE A LICENCE

See Note Below Attendance at Seminar/Training Session

Incident Officer	1	Refer to Note 1
Secretary of the Meeting	2 and 4	Will receive Training at meetings and if required at Regional or ACU HQ Seminars.
Technical Official		Will receive training via the Chief Technical Officer at meetings. May attend Regional Training Seminars
Club Stewards	3	May attend Regional or ACU HQ Seminars for information purposes
Chief Marshal		May receive training at ACU HQ or Regional Training Days
Marshal		May receive training at Regional Training days and at meetings via the Chief Marshal.
Medical Officer		None required

Registration of the above officials and marshals will be renewed annually. All such Officials will receive an appropriate form of identification from the ACU.

Note 1 Incident Officer

Will collate all information and documentation, and prepare reports relating to serious accidents and to all incidents involving Officials or Spectators.

For 2019 it is recommended that the Incident Officer is at least a Probationary Clerk of the Course or has attended an Incident Officer Seminar.

For 2020 and onwards the Incident Officer will be required to hold at least a Probationary Clerk of the Course licence or have attended an Incident Officer Seminar.

Note 2 Secretary of the Meeting

Will be responsible for all administration connected with the organisation of a meeting.

Note 3 Club Stewards

Stewards of the meeting exercise judicial authority over the running of the meeting according to the National Sporting Code and Supplementary Regulations.

Note 4 Secretary of the Meeting Registration

Currently there is no requirement for these officials to be registered for Road Race Disciplines.

SECTION 4 PRACTICE

4.1 TIME MUST BE PUT ASIDE FOR THE PRACTICE SESSIONS AND THESE MUST BE DEFINED IN THE SUPPLEMENTARY REGULATIONS FOR THE MEETING.

1. Riders will commence practice under the instructions of the Start Officials.
2. The duration of each practice session will commence from the time the first rider joins the circuit and will finish not less than 10 minutes later.
3. The end of practice will be indicated by the waving of a chequered flag at which time the pit exit will be closed. A rider's time will continue to be recorded until he passes the finish line after the allotted time has lapsed.
4. If practice is interrupted due to an incident or any other reason then a red flag will be displayed at the start line and at marshals posts. All riders must return slowly to the pit lane or as otherwise instructed by the Marshals under the direction of the Clerk of the Course.
5. When the practice is restarted the time remaining will be decided by the Clerk of the Course.

SECTION 5 GRID POSITIONS

5.1 POSITIONS

1. Pole position, and the configuration of the grid, will be determined at the time of the Track Inspection.
2. Grid positions will be established according to the provisions of the Supplementary Regulations.

5.2 TIMED PRACTICE

Where timed practice is used and identical times are recorded by more than one rider in the official qualifying practice session for the race the rider first setting such a time will receive the better starting position.

A qualifying maxima may be specified in the Supplementary Regulations.

5.3 BALLOTTED

Where the Organiser decides that the grid positions will be by ballot this must be conducted by the competitors at the meeting.

5.4 ALLOCATED

Organisers wishing to allocate grid position will specify this and the method to be adopted in the Supplementary Regulations.

SECTION 6 START PROCEDURES

Races may be started by one of the following methods:

GROUP STARTS

Which include the 45 degree echelon line up known as the Le Mans start.

INTERVAL STARTS

Where competitors are started individually or in groups at pre-determined intervals. Starts may be made with engines running or engines stopped. For starts with engines stopped the Supplementary Regulations for the race must specify the authorised method of starting.

CLUBMANS RACES

1. Riders collect in the Assembly Area and proceed when directed to the Grid to take up their allocated Grid positions.
2. An Official will signal all the Riders to proceed on a warm-up lap (of the circuit being used for the race) by waving a Green Flag. On completion of the warm-up lap the riders each return to their allocated Grid positions.
3. Riders who do not go on to the Grid may join the warm-up lap from the Pit Lane on the instruction of the Officials, but in this case must start the race from the back of the Grid.
4. On the completion of the warm-up lap an Official will display a Red Flag at the front of the Grid.
5. When the grid is re-formed the Official with the Red Flag will leave the Grid indicating to the Riders that the race is about to commence.
6. Any Rider who stalls his engine on the Grid, or who has other difficulties, must remain on his motorcycle and raise an arm. It is not permitted to attempt to delay the start by any other means.
7. A Red light will be displayed for up to 5 seconds. The Red Light will then be extinguished to start the race. Alternatively, the National Flag may be lowered to start the race.
8. After the Riders have passed the exit of the Pit Lane any Riders waiting there may be permitted to join the race at the discretion of the Clerk of the Course and under the instructions of the Officials.
9. Should there be a problem on the Grid, the Starter may display a Yellow Flag or Yellow lights to indicate a delayed start. The Clerk of the Course may decide that the Riders will complete another warm-up lap and the race distance may be reduced.

NATIONAL RACES

1. Riders proceed as directed to the Grid upon the opening of the Pit Lane and take up their starting positions.
2. Riders take up their allocated positions on the Grid. Riders who encounter technical problems must go to the Pit Lane to make adjustments or to change machines.
3. Two minutes before the start of the race the Starter will signal all the Riders to proceed on a warm-up lap by waving a Green Flag. On completion of the warm-up lap the riders each return to their allocated Grid positions.
4. Riders not going on to the Grid may join the warm-up lap from the Pit Lane on the instructions of the Officials but in this case must start the race from the rear of the Grid.
5. On completion of the warm-up lap an Official will display a Red Flag at the front of the grid.
6. When the Grid is re-formed the Official with the Red Flag will leave the track indicating to the Riders that the race is about to commence.
7. Any Rider who stalls his engine on the Grid or who has other difficulties must remain on his motorcycle and raise an arm. It is not permitted to delay the start by any other means.
8. A Red Signal light will be displayed for up to 5 seconds. The Red Light will then be extinguished to start the race. Alternatively, the National Flag may be lowered to start the race.
9. After the Riders have passed the exit to the Pit lane any Riders waiting there may be permitted

to join the race at the discretion of the Clerk of the Course and under the instructions of the Officials.

10. Should there be a problem on the Grid, the Starter may display a Yellow Flag or Yellow lights to indicate a delayed start. Riders will stop engines. One assistant per team may enter the grid to assist the competitors. The Rider(s) responsible for the delay will start from the back of the Grid. The Riders will complete another warm-up lap and the race distance will be reduced by one lap.

ANTICIPATION OF THE START

1. Anticipation of the Start is defined as when the motorcycle is moving forward when the Red Lights are on.
2. Any Competitor who takes up an incorrect Grid position will be judged to have anticipated the Start.
3. The Clerk of the Course will award a Time Penalty of up to 20 seconds to any Rider who anticipated the Start. The decision as to an anticipated Start is to be accepted as a Matter of Fact from which there is no right of Protest.

SECTION 7 FLAGS AND LIGHTS

Marshals and other officials display flags or lights to provide information and/or convey instructions to the riders:

7.1 FLAGS AND LIGHTS USED TO PROVIDE INFORMATION

1 NATIONAL FLAG OR START LIGHTS

1. Signal for the Start of the Race. A Red light will be displayed for up to 5 seconds. The Red Light will then be extinguished to start the race. Alternatively, the National Flag may be lowered to start the race.

2 GREEN FLAG

1. The track is clear.
2. This flag will be shown waved by the starter to signal the start of the warm up lap.
3. This flag must be shown motionless at each flag marshal post for the first lap of each practice session and of the warm up, for the sighting lap(s) and for the warm up lap.
4. This flag must be shown motionless at the flag marshal post immediately after the incident that necessitated the use of one or more yellow flags.

3 YELLOW AND RED STRIPED FLAG

1. Oil, water or other substance is affecting adhesion on this section of the track.
2. This flag must be shown motionless at the flag marshal post.

4 YELLOW AND RED STRIPED FLAG: NATIONAL EVENTS ONLY

1. The adhesion on this section of the track could be affected by any reason other than rain.
2. This flag must be shown motionless at the flag marshal post.

5 WHITE FLAG WITH DIAGONAL RED CROSS: NATIONAL EVENTS ONLY

1. Drops of rain on this section of the track.
2. This flag must be shown motionless at the flag marshal post.

6 WHITE FLAG WITH DIAGONAL RED CROSS + YELLOW AND RED STRIPED FLAG: NATIONAL EVENTS ONLY

1. Rain on this section of the track.

2. These flags must be shown together motionless at the flag marshal post.

7 BLUE FLAG

1. National events and above. Not mandatory at Club level events.
2. May be shown waved, this flag indicates that a faster rider is about to overtake.
3. The use of this flag is optional at meetings of lower than National Status. Shown waved at the flag marshal post, this flag indicates to a rider that he is about to be overtaken.
4. During the practice sessions, the rider concerned must keep his line and slow down gradually to allow the faster rider to pass him.
5. During the race, the rider concerned is about to be lapped. He must allow the following rider(s) to pass him at the earliest opportunity.

8 YELLOW FLAG WITH BLACK DIAGONAL CROSS

1. This flag will be shown motionless at the finish line at track level to indicate the commencement of the final lap of the race.

9 CHEQUERED BLACK AND WHITE FLAG

1. This flag will be waved at the finish line on track level to indicate the finish of race or practice session.

10 CHEQUERED BLACK AND WHITE FLAG PLUS BLUE FLAG

1. The chequered black/white flag will be waved together with the blue flag presented motionless at the finish line on track level when a rider(s) precedes closely the leader during the final lap before the finish line.

7.2 FLAGS USED TO CONVEY INFORMATION AND INSTRUCTIONS

1 YELLOW FLAG AND OR YELLOW LIGHTS

1. Shown waved at each row of the starting grid, this flag indicates that the start of the race is delayed.
2. When shown stationary at the flag marshal post this flag indicates danger ahead, riders must slow down.
No overtaking is permitted.
3. When shown waved at the flag marshal post this flag indicates that the danger is more imminent. The riders must be prepared to stop.
4. Overtaking is forbidden up until the point where the green flag is shown.
5. Any infringement of this rule during a practice session will result in the cancellation of the time of the lap during which the infraction occurred.
6. In case of infringement of this rule during the race, a time penalty will be imposed. In both cases, further penalties (such as fine – suspension) may also be imposed.
7. During the final inspection lap (by the Stewards and other Officials) this flag must be waved at the exact place where the flag marshal will be positioned during the practices, warm ups and races.

Note: Following an incident during a practice or race the Yellow Flags are usually displayed as follows:

1. Shown waved at the flag marshals' post immediately prior to the incident.
2. Shown stationary at the flag marshals' post preceding the post at which it is being shown waved.
3. Additional flags may be shown at the request of the Clerk of the Course.

2 WHITE FLAG

1. National events only. Not permitted at Club level.
2. An intervention vehicle is on the track.
3. Waved at the flag marshal post, this flag indicates that the rider will encounter the vehicle in the current section of the track.
4. It is forbidden for a rider to overtake another rider during the display of the white flag.
5. Overtaking the intervention vehicle is permitted.
6. As soon as such a vehicle stops on the track, the white flags must be maintained and the yellow flags must also be presented.

Note: At a meeting of below National status no Ambulance or Fast Intervention Vehicle will be allowed to be moved onto the course or its immediate verges whilst racing or practice is in progress on any part of the circuit. This means that in circumstances when an Ambulance or Fast Intervention Vehicle is required on the circuit, the Red Flags must first be displayed and the race or practice brought to an actual and effective halt before any vehicle is deployed.

3 RED FLAG WITH A WHITE DIAGONAL CROSS. ENDURANCE RACES ONLY.

1. The race is neutralised.
2. Riders must slow down and be prepared to catch up a SAFETY CAR.
3. It is forbidden for a rider to overtake another rider during the display of this flag.
4. Overtaking the SAFETY CAR is forbidden.
5. Riders must line-up in single file behind the Safety Car.
6. This flag must be shown motionless at each flag marshal post,
7. At all meetings where this flag is used a riders briefing must be held.

4 RED FLAG AND RED LIGHTS

1. When the race or practice is being interrupted, the red flag will be waved at each flag marshal's post. Riders must return slowly to the pits or as directed by the Marshals.
2. Any infringement of this rule will be penalised with one of the following penalties: fine -disqualification - withdrawal of Championship points - suspension.
3. The red flag will be shown motionless on the starting grid at the end of the sighting lap(s) and at the end of the warm up lap.
4. The red flag may also be used to close the track.
5. The red lights will be switched on at the start line for up to 5 seconds to start each race.

5 BLACK FLAG

1. This flag is used to convey instructions to one rider only and is displayed motionless together with the rider's number.
2. The rider must stop at the pits at the end of the current lap and cannot restart.
3. Any infringement of this rule will be penalised with one or more of the following penalties: fine - disqualification - withdrawal of Championship points - suspension.

6 BLACK FLAG WITH ORANGE DISK (RADIUS 40 CM)

1. This flag is used to convey instructions to one rider only and is displayed motionless together with the rider's number.
2. This flag informs the rider that his motorcycle has mechanical problems likely to endanger himself or others, and that he must immediately leave the track.
3. Any infringement of this rule will be penalised with one or more of the following penalties: fine - disqualification - withdrawal of Championship points - suspension.

7.3 FLAG DIMENSIONS

The flag dimension should be approximately 80cms in the vertical and 100cms in the horizontal.

7.4 FLAG COLOURS

The Pantones for the colours are as follows:

Orange: Pantone 151C
Black: Pantone Black
C
Blue: Pantone 286C or
298C Red: Pantone 186C
Yellow: Pantone Yellow
CGreen: Pantone 348C

7.5 FLAG MARSHALS' POSTS

The position of the Flag Marshals' Posts will be fixed during the ACU Track Inspection.

7.6 MARSHALS' OVERALLS

It is recommended that Marshals' overalls be Orange (Pantone 151C) or white in colour. Waterproofs should be of the same colour or transparent.

SECTION 8 BEHAVIOUR DURING PRACTICE AND RACE

8.1 RIDERS MUST OBEY THE FLAG SIGNALS, THE LIGHT SIGNALS, AND THE BOARDS WHICH CONVEY INSTRUCTIONS. ANY INFRINGEMENT TO THIS RULE WILL BE PENALISED ACCORDING TO THE PROVISIONS OF SECTION 7.

1. Riders must ride in a responsible manner which does not cause danger to other competitors or participants, either on the track or in the pit-lane. Any infringement of this rule will be penalised with one of the following penalties: fine – time penalty – disqualification – withdrawal of Championship points – suspension.
2. Riders should use only the track and the pit-lane. However, if a rider accidentally leaves the track then he may rejoin it at the place indicated by the marshals or at a place which does not provide an advantage to him. Any infringement of this rule during the practices or warm up will be penalised by the cancellation of the lap time concerned and during the race, by a time penalty. Further penalties (such as fine – disqualification – withdrawal of Championship points) may also be imposed.
3. Any repairs or adjustments along the race track must be made by the rider working alone with absolutely no outside assistance. The marshals may assist the rider to the extent of helping him to lift the machine and holding it whilst any repairs or adjustments are made. The marshal may then assist him to re-start the machine.
4. If the rider intends to retire, then he must park his motorcycle in a safe area as indicated by the marshals.
5. If the rider encounters a problem with the machine which will result in his retirement from the practice or the race, then he should not attempt to tour at reduced speed to the pits but should pull off the track and park his machine in a safe place as indicated by the marshals.
6. Riders are not permitted to return slowly to the pits for any reason during practice or racing.
7. Riders may enter the pits during the race, but taking the motorcycle inside the pit box is not permitted. Any infringement of this rule will be penalised with a disqualification. Riders who stop their engines in the pits may be assisted to re-start their motorcycle by the mechanics.
8. Riders are not allowed to transport another person on their machine or to be transported by another rider on his machine.
9. Riders must adopt a position with their feet on the footrests.
10. Riders who fall from their machine are not permitted to continue with the practice or race until passed fit by the Medical Officer and the machine re-inspected by technical control.

11. Riders must not ride or push their motorcycles in the opposite direction of the circuit, either on the track or in the pit lane, unless doing so under the direction of an Official.
12. No signal of any kind may pass between a moving motorcycle and anyone connected with the motorcycle's entrant or rider, save for the signal from the time keeping transponder, or legible messages on a pit board or body movements by the rider.
Automatic timing devices, provided they do not disrupt official timekeeping methods, are not considered as telemetry.
13. The carrying of on board cameras is only permitted with the prior approval, in writing of the Clerk of the Course. The installation of the camera must be approved by the Chief Technical Officer.
14. A speed limit may be imposed in the Pit Lane.
 1. Any rider found to have exceeded the limit during the practice will be subject to a penalty as described in the Supplementary Regulations.
 2. Any rider who exceeds the pit lane speed limit during a race will be penalised with a time penalty as described in the Supplementary Regulations.
 3. The Clerk of the Course must communicate the offence to the pit of the rider.
15. In the interest of safety, a rider may not stop his machine on the racing surface during the slow down lap, (exception see Art 8.17) when returning to the pits after the chequered flag.
16. Stopping on the track during practices and races is forbidden. (exception see Art 8.17)
17. During the practice sessions and warm ups, practice starts are permitted, when it is safe to do so, at the pit lane exit before joining the track and after the chequered flag is shown at the end of practice sessions and warm ups, when it is safe to do so. These practice starts must take place off the racing line.
18. The spinning of rear wheels (burn-outs) is strictly forbidden. Breach of this rule will result in apenalty of disqualification.
19. Any competitor who in any ACU or MCRCB Permitted Event participates on a machine for which he is not eligible through age or licence restrictions will be penalised by a fine of £500.00 and a suspension for one year from the date of the hearing.

8.2 **PROTESTS**

1. Any Rider, Passenger, Entrant or Official licensed by the ACU affected by a decision taken during a meeting held under an ACU Permit has the right to protest against that decision.
2. No protest may be lodged against a decision of statement of fact of the Race Direction to inflict or not:
 - A time penalty
 - A change of position
 - A ride through
 - A disqualification from the practice sessions or races by means of a black flag or black flag with orange disc.
 - A fine for speeding in the pit lane.

SECTION 9 NEUTRALISATION OF RACES – SAFETY CAR

A compulsory riders briefing on these Regulations must be conducted by the Clerk of the Course or his Deputy prior to any race in which the use of Safety Cars is intended. The Safety Cars if they are to go on the track must be equipped with Yellow Flashing lights. The words "Safety Car" should be clearly indicated on the back and the sides of the car. The Driver of the Safety Car should be the holder of an ACU or FIM Clerk of the Course or Competition Licence for Road Racing, a MSA Competition Licence or an ARDS Licence. All "Safety Car" drivers must be assisted in the car by a Race Official who is in constant contact with the Clerk of the Course.

If during a race of 20 miles or more an incident other than rain puts at risk the safety of the competitors and renders impossible the normal progress of the competition the Clerk of the Course

(Grade National A or above or of Grade National B with the prior individual approval of the Road Race Committee) may decide to neutralize the race.

The following procedure will be adopted:

1. A Red Flag with a White Diagonal Cross must be displayed at the selected Marshals Posts during the whole of the neutralisation period.
2. A White Board showing the words "Safety Car" will be displayed at the Start Line during the whole of the neutralisation period.
3. Riders must immediately slow down. Overtaking is forbidden. The Track Marshals will record all infringements and report them to the Clerk of the Course.
4. The pit lane exit will be closed to competitors.
5. When the leading competitor approaches the start line at the end of the lap that the neutralisation was decided a "Safety Car" equipped with two flashing Yellow Lights on the roof will enter the track with two flashing lights switched on.
6. The competitors will end up in single file behind the "Safety Car" without overtaking it.
7. Competitors may now enter the pits but all other rules must be complied with.
8. After stopping at the pits competitors must line up at the pit lane exit and must only rejoin the circuit when instructed to do so by the official with a Green Flag or when the Green Light at that location is switched on. These instructions will be given 10 seconds after the last competitor in line behind the "Safety Car" has passed that point. Competitors must join the back of the line and MUST NOT overtake. The pit lane exit will then be closed and competitors must wait for the next lap.
9. During the last lap of the neutralisation period the "Safety Car" will switch off the Lights on the roof to indicate to the competitors that the "Safety Car" will enter the pit lane at the end of that lap and the race will resume.
10. When the "Safety Car" has left the track overtaking is forbidden up until the start line, where a Green Flag will be waved and the Red Flag with a White Diagonal Cross immediately withdrawn.
11. The pit lane exit will then be permanently re-opened.
12. The race will continue normally.
13. Unless otherwise decided by the Clerk of the Course, each lap completed by the "Safety Car" will be counted as a race lap. A Board displaying the new actual number of laps remaining will be displayed on the start line when the green flag is waved. If the race is eventually stopped under SR 9.1 whilst the "Safety Car" is deployed the result will be according to the position at the last completed lap before the "Safety Car" was introduced.
14. No Protest may be lodged against the decision of the Clerk of the Course regarding the number of laps remaining in order to complete the race.
15. All other rules of the race must be observed.

SECTION 10 INTERRUPTION OF A RACE

10.1 IF THE CLERK OF THE COURSE DECIDES TO INTERRUPT A RACE DUE TO CLIMATIC CONDITIONS OR SOME OTHER REASON, THEN RED FLAGS WILL BE DISPLAYED AT THE FINISH LINE AND AT ALL FLAG MARSHALS' POSTS.

1. Riders must immediately slow down and return to the pit lane, or as directed by the marshals upon instructions from the Clerk of the Course.
2. Only riders still racing when the red flag is displayed will be counted as finishers.
3. The results will be the results taken at the last point where the leader had completed a full lap without the red flag being displayed calculated as in the principle set out in the following example:

Example of a race consisting of 30 laps:

If a Red Flag is shown when the leader is on his 10th lap after completing his 9th lap and all

other riders have not completed the 9th lap, then the race result will be 9 laps completed, and the second part will consist of 21 laps.

Exception: if the race is interrupted after the chequered flag, the following procedure will apply:

4. For all the riders to whom the chequered flag was shown before the interruption, a partial classification will be established at the end of the last lap of the race.
5. For all the riders to whom the chequered flag was not shown before the interruption, a partial classification will be established at the end of the penultimate lap of the race.
6. The complete classification will be established by combining both partial classifications as per the lap/time procedure.
7. If the results calculated show that less than three laps have been completed by the leader of the race and by all other riders on the same lap as the leader, then the race will be null and void and a completely new race will be run. If it is found impossible to re-start the race, then it will be declared cancelled and the race will not count for any Championship.
8. If three laps or more have been completed by the leader of the race, and all other riders on the same lap as the leader, but less than two-thirds of the original race distance, rounded down to the nearest whole number of laps, then the race will be restarted. If it is found impossible to restart the race, then the results will count and half points will be awarded in any Championship.
9. If the results calculated show that two-thirds of the original race distance rounded down to the nearest whole number of laps have been completed by the leader of the race, then the race will be deemed to have been completed and full Championship points will be awarded.
10. Exception: Where a race is interrupted at a meeting of below National Status the Clerk of the Course is permitted to decide that the race has been completed or to run a new race over a distance appropriate to the prevailing conditions.

SECTION 11 RE-STARTING A RACE THAT HAS BEEN INTERRUPTED

11.1 IF A RACE HAS TO BE RE-STARTED, THEN IT WILL BE DONE AS QUICKLY AS POSSIBLE, CONSISTENT WITH TRACK CONDITIONS ALLOWING. AS SOON AS THE RIDERS HAVE RETURNED TO THE PITS THE CLERK OF THE COURSE WILL ANNOUNCE A TIME FOR THE NEW START PROCEDURE TO BEGIN WHICH, CONDITIONS PERMITTING, SHOULD NOT BE LATER THAN 10 MINUTES AFTER THE INITIAL DISPLAY OF THE RED FLAG.

1. The results of the first race must be available to the riders before the second part of a race can be started.
2. The start procedure will be identical to a normal start with sighting lap(s), warm-up lap etc.
3. Conditions for the re-started race will be as follows:
 1. In the case of the situation described in Article 10.7 above (less than 3 laps completed) All riders may re-start.
 2. Motorcycles may be repaired or changed. Refuelling is permitted.
 3. The number of laps will be the same as the original race.
 4. The grid positions will be as for the original race.
4. In the case of situation described in Article 10.8 above (3 laps or more and less than two-thirds completed)
 1. Only riders who are classified as finishers in the first race may re-start. Article 12.3.
 2. Motorcycles may be repaired or changed. Re-fuelling is permitted.
 3. The number of laps of the second race will be the number of laps required to complete the original race distance with a minimum of 5 laps.
 4. The grid position will be based on the finishing order of the first race.
 5. The final race classification will be established according to the position and the number of laps of each rider at the time he crossed the finish line at the end of the last part of the race.

5. Exception: Provisions of Article 10.10 may apply according to the status of the meeting. (The discretion of the Clerk of the Course to decide at meetings of lower than National status.)

SECTION 12 FINISH OF A RACE AND RACE RESULTS

12.1 FINISH OF A RACE

1. When the leading rider has completed the designated number of laps (or the designated time in the case of Endurance) for the race, a Chequered Flag will be displayed at the finishing line.

12.2 THE CHEQUERED FLAG WILL CONTINUE TO BE DISPLAYED TO THE SUBSEQUENT RIDERS.

1. After the Chequered Flag is displayed to the leading Rider no other Rider is permitted to enter the track from the Pit Lane.
2. If a Rider closely precedes the leader during the final lap before the finish line the Official will show to the Riders and to the Leaders simultaneously the Chequered Flag and the Blue Flag. This will indicate to the Leader that he has completed the race and to the Rider closely preceding the Leader that he still has to complete the final lap.
3. In the case of a photo finish between two or more Riders the decision shall be taken in favour of the Rider whose Front Wheel leading edge crossed the finish line first. In the case of Ties, the Riders concerned will be ranked according to the best lap times they achieved in the race.
4. The Clerk of the Course may require machines to be presented for post Practice or Race verification. Where this is required the Riders must be informed prior to the start of the Practice or Race that they must attend the "Parc Ferme".

12.3 RACE RESULTS

1. When the Race has been completed as described above the Results will be based on the order in which the Riders crossed the finish line and the number of laps that they have completed.
2. When the Race has been declared completed by the Clerk of the Course following an Interruption under Article 10.3, the result will be established according to the procedure described in Articles 10.4–10.6 for a race interrupted after the Chequered Flag.
3. In either of the cases described in 1) and 2) above. To be counted as a Finisher and be included in the results a Rider must have completed 75% of the actual race distance. He must also have crossed the finish line on the track and not in the Pit Lane within two minutes after the winner and be in contact with his machine.
4. A new Lap record can only be established during a race.
5. Both for the Practice and for the Race, the lap time is the subtraction of the time between two consecutive crossings of the finish line.

SECTION 13 SAFETY

13.1 MEDICAL SERVICES – MINIMUM REQUIREMENTS FOR ROAD RACE MEETINGS

	PERSONNEL			VEHICLES		
	Doctors MO	Paramedic(s) PM	First Aid personnel	Ambulance(s)	Fast Intervention Vehicle	Special Notes
Road race	2 MOs	PMs can assist MOs but not replace them	5	2	1	(i)
Road race Test day	1 MO	1 PM	2	1	1	

The following applies to all events run under this code:

- Medical Officer (MO) – Doctor** A medical practitioner (Doctor) fully registered with the General Medical Council (GMC), and holding appropriate personal medical malpractice insurance cover (excludes NHS Crown Indemnity).
- Paramedic (PM)** A State Registered Paramedic with the HPC (Health Professions Council) Paramedics must have appropriate personal medical malpractice insurance cover.
- Ambulance** A vehicle registered as an ambulance with the DVLA (Driver and Vehicle Licensing Agency) and registered with CQC if appropriate. An ambulance must have an appropriately qualified driver to transport a casualty under blue lights. It must be equipped with the FIM minimum equipment regulations for a type C vehicle; that is: Medical: A stretcher (preferably standardised), oxygen supply, apparatus to immobilise limbs and vertebral column. First aid medicaments and materials.
Technical: Radio communication. Visible and audible signals.
Staffing: An ambulance must be staffed by two First Aid Personnel (who can be the two minimum First Aid Personnel).
An ambulance may act as a Medical Centre BUT if so it must be a vehicle in addition to the minimum ambulance requirement.
- First Aid Personnel** A person holding a current certificate of First Aid competency. (Where an event is open to the public event organisers should ensure that all First Aid personnel are insured against malpractice for the event concerned).
- Fast Intervention Vehicle (FIV)**
 - A Fast Intervention Vehicle is a compulsory requirement at all Road Race events.
 - Such a vehicle requires a driver, a Doctor, and appropriate medical equipment. If the driver is not a First Aid Person, then such a Person must be present in the vehicle. This vehicle must be immediately available to proceed to an incident, if called to do so, upon instructions from the Clerk of the Course.
 - A FIV must not be used in place of an ambulance.
 - A Fast Intervention Vehicle must be equipped with visible signals (flashing lights).
 - At a meeting of below National status no ambulance or Fast Intervention Vehicle is allowed to be moved onto the course or its immediate verges whilst racing or practice is in progress on any part of the circuit. This means that in the circumstances when an Ambulance or Fast Intervention Vehicle is required on the circuit, the Red Flags must first be displayed and the race or practice brought to an actual and effective halt before the vehicle is deployed.
Note: This restriction is not applicable where the Clerk of the Course has decided to neutralise the race by use of the Safety Car in accordance with the provisions of Section 9 of the Road Race Regulations.
- During Sighting Lap:** Stationary or moving Ambulances, Fast Intervention Vehicles, and the like, may be encountered anywhere on the circuit when riders are dispatched from the

Assembly Area on their "sighting lap" to the start line prior to the start of a race. This "sighting lap" is not considered to be either Practice or Racing and riders must always be prepared to encounter such vehicles. When such a vehicle or vehicles are on the track the Yellow Flags will be displayed in the appropriate section of the course.

Special Notes

2 MOs must be present at the start of every meeting and be present for the duration of the meeting unless accompanying a patient to hospital. If vehicles or First Aid personnel leave the circuit to convey a patient to hospital then the minimum requirements for the event to continue are 1 MO, 1 FIV, 2 Ambulances and 4 First Aid personnel.

6. **Medical Examination** At any time during a meeting the Clerk of the Course may require a competitor to undergo a medical examination to determine his fitness to participate. The decision of the Medical Officer is a matter of fact without right of protest.

Concussion/suspected concussion If a competitor is involved in an incident which results in him being diagnosed by the Medical Officer/Paramedic as suffering from concussion/suspected concussion, the rider is not permitted to participate any further in that event.

Organisers are to notify ACU Head Office as soon as possible of any concussion/suspected concussion injuries and then will subsequently:

- a) Place the rider on the ACU Stop List
- b) Inform Organisers of forthcoming events that the Rider has suffered a concussion/ suspected concussion injury and is therefore placed on the ACU Stop List
- c) Inform the Rider that he needs to see a Doctor and obtain a letter/doctor's certificate which confirms he is fit to resume competitive racing/participate in a practice/test session.

The recovery time for anyone diagnosed with concussion/suspected concussion is as follows:

- a) Over 20 years: Excluded immediately and suspended for a period of nine days.
- b) 16-19 years: Excluded immediately and suspended for a period of twelve days.
- c) 15 and under: Excluded immediately and suspended for a period of twenty three days. The rider is not permitted to ride during the obligatory suspended periods outlined above and then only once he is in possession of a doctor's certificate/letter after the suspended period has expired.

A rider may be signed off to ride by the CMO at an event once he has observed the obligatory suspended period outlined above.

If a competitor has been injured on a Saturday and is suffering from concussion/suspected concussion, and the Organiser is aware that the rider was intending to ride or is scheduled to ride somewhere else the next day, the Organiser will inform the Organiser of the event being held the next day so they are aware of the rider's injuries and as such he is prevented from participating in that event.

13.2 TRACK SAFETY PRECAUTIONS

1. The safety precautions of circuits will be as laid down for each Permanent Course Licence or Temporary Course Certificate following an inspection of the course.
2. It should be generally realised that the organisers of speed events have a legal responsibility to the general public and therefore it is the duty of these organisers to ensure that all reasonable precautions are taken to protect the public.
3. Whilst organising Clubs are insured under the Promoter's Third Party Policy in respect of their legal liability, it is a condition of the policy that the promoters of an event must comply strictly with the National Sporting Code and any additional requirements as may be specified by the Permanent Course Licence or Temporary Course Certificate. Clubs failing to do so stand in grave danger of any claims being repudiated to the Club by the insurers under the terms of the policy covering legal liability.
4. The safety precautions to be adopted are provided with the Permanent Course Licence or

Temporary Course Certificate for the particular course but the following general requirements must be observed.

5. The attention of organisers is drawn to the provision of the NSC which stipulates that no alteration of the requirements contained in the Permanent Course Licence or Temporary Course Certificate shall be made without the prior approval, in writing, of the ACU.
6. It is recognised that circumstances may arise in which it is necessary to make certain alterations to the course on the day of the meeting but any such alterations must be approved by the Stewards of the Meeting and details given in their report to the permit issuing authority.

13.3 FIRE EXTINGUISHERS

Each working vehicle in the Paddock must have a 2kg (minimum) dry powder fire extinguisher available for immediate use. This extinguisher must show the date of the last annual inspection. Noncompliance with this regulation will incur a penalty imposed by the Clerk of the Course.

13.4 FIRE EXTINGUISHERS AT CIRCUITS

At all race and speed events, there must be a valid certificate, issued annually immediately prior to the start of each season's racing by the manufacturer or his agent, to the effect that all fire extinguishers are in effective working order. This certificate must be available for inspection by the Stewards.

All fire posts must be clearly marked. In addition to the fire equipment at each post there must be:

1. Fire extinguishers in the paddock and assembly area.
2. At least two fire extinguishers in the Technical Control Area.
3. Fire extinguishers in every medical room/centre.
4. During events of National status or below where machines may be refuelled and more than five gallons (22 litres) of fuel is held in any one pit, there shall be a minimum of one fire tender and crew in attendance, appropriately equipped and with immediate access to the pit area. International events must comply with appropriate FIM requirements.

13.5 WARNING AND PROHIBITION SIGNS AT CIRCUITS

For full details regarding Warning Notices and Prohibition Notices please refer to the Safety Precautions section of this Handbook.

1 WARNING NOTICES

The following requirements regarding the display of Warning notices are applicable to all Road Racing events.

1. WARNING NOTICE (A) (29 × 20 inches.) Warning notices as detailed below must be displayed on each side of every entrance to the course, including the entrance to car parks and paddock.
These notices must be prominently displayed where they can be easily read by the public before any admission charge is paid, or where no admission charge is made before entry is gained into the circuit.
Where it is not possible to define the limits of the site and to control admission of the public (e.g. M.O.D. Land and heath land) warning notices must be profusely displayed around the course and also in the car parks.
2. WARNING NOTICE (B) (20 × 15 inches.) Those parts of the course to which the public may be admitted and where it is neither practical nor necessary to erect a barrier, e.g. those parts of the course which are straight and are only used by the public to reach other parts of the course, may be indicated by the erection of the special type of Warning Notice (B). These notices should be displayed at least 30ft from the course. It is recommended that the limit of these areas should also be defined by a boundary tape.

2 PROHIBITION NOTICES

The following requirements regarding the display of Prohibition notices are applicable to all Road Racing events.

PROHIBITED AREA NOTICE (C) (29 × 20 inches.) Areas where the public are not permitted must be clearly defined by the display of an adequate number of "Prohibited Area" notices (B).

Notices should be displayed within the prohibited area, facing the public.

13.6 DECLARATION – ADMISSION TICKETS, ARMBANDS AND PASSES

Subject to the provision of the Sunday Observance Act 1780, no person may be allowed to any part of the circuit without a suitable pass or ticket. All tickets and passes must bear the following wording shown below in full and if the wording appears on the reverse side then the words "For Conditions of Admission See Over" must be clearly printed on the face thereof. Where a ticket is cancelled by being torn in half, the full wording and, where applicable, the "For conditions of admission see over" must appear on each half. Where a charge is made for admission into special or "reserved" enclosures a ticket bearing the approved declaration must be issued in exchange for payment to enter these enclosures.

Declaration.

WARNING. MOTOR SPORT CAN BE DANGEROUS. Despite the organisers taking all reasonable precautions, unavoidable accidents can happen. Please comply with all instructions of marshals and notices and remain in permitted areas only. THEY ARE CONCERNED WITH YOUR SAFETY.

All vehicle passes must bear the same wording and comply with the above requirements.

13.7 DECLARATION ON THE OFFICIAL PROGRAMME

The declaration as outlined above should be printed in full on the outside front cover of all Official Programmes. Where this is not possible it must be printed in full in the programme and the words "For conditions of admission see inside" printed on the outside cover.

13.8 SIGNING ON

All riders, passengers, officials and press must sign a declaration on the relevant signing on form (available from the ACU).

1. Age Limits for Officials
All event Executive and Administrative Officials shall be 18 years of age or over.
2. Age Limits for Marshals
 1. All Assistant Officials whose function is to be carried out at the immediate trackside must be at least 16 years of age.
 2. All Assistant Officials who are under 18 years of age must have obtained parental agreement to carry out the duty and the signing-on signature must be countersigned by the person responsible for the official at the event.
 3. When using the services of officials under 18 years of age for any duties at any event special attention must be given to any risks which may be associated with the duty, and to the previous experience of the official.

SECTION 14 GENERAL SPECIFICATIONS

14.1 PROTECTIVE CLOTHING

During practice and racing riders and passengers must wear the following clothing and footwear:

1. A complete all in one leather suit of at least 1.2mm in thickness on all parts of the suit. Suits zipped together at the waist are not permitted. Non-leather material may be used if it meets with the following requirements.
2. The following characteristics of the material must be at least equivalent to 1.5mm of cowhide (not split leather).

- Fire retardant quality – Resistance to abrasion – Coefficient of friction against all types of asphalt – perspiration absorbing qualities – Medical test – non toxic and non allergenic – Fabric of a quality that does not melt. It must be non-flammable.
3. The following areas must be padded with at least a double layer of leather or enclosed plastic foam at least 8mm thick:
Shoulders, elbows, both sides of the torso and hip joint, the back of the torso, knees.
 4. Competitors must wear complete undergarments if they use suits which are not lined. Suitable undergarments may be of the Nomex type, they may also be of silk or simply cotton. Synthetic materials which may melt and which could harm the riders skin in an accident are not allowed, neither for the suit nor for the undergarments.
 5. Competitors' footwear must be of leather or an approved substitute material and of a minimum height of 200mm to provide, with the suit, complete protection (i.e. no exposed areas).
 6. Competitors must wear leather protective gloves.
 7. The use of metallic material in any item of clothing or personal protection which regularly comes into contact with the track is prohibited (i.e. metal studs in knee sliders, boots etc.).

14.2 HELMETS

Helmets bearing the current ACU gold stamp and in sound condition and properly fitted must be worn by all riders and passengers while practising and racing. Overseas riders may use helmets as approved by their own FMN.

14.3 IDENTIFICATION DISCS

While practising and racing, riders and passengers are required to wear an identification disc around the neck, attached by a material approved by the technical officer. Thin chains should be avoided. The disc must be permanently marked with the wearer's full name and date of birth. Identification discs shall be of a durable material, circular in shape, between 20mm and 25mm in diameter and having rounded edges with no sharp or ragged projections.

14.4 BODY JEWELLERY

It is recommended that any body piercing studs, ring etc. are removed.

SECTION 15 GENERAL REGULATIONS FOR SOLO MOTOR SCOOTERS

15.1 INTRODUCTION

These Regulations specify the requirements for construction of Motor Scooters for use in Road Races, Sprints and Hill Climbs.

15.2 TERMS & DEFINITIONS

1. Machine(s): A term used to refer to a permitted Solo Motor Scooter within the confines of these Standing Regulations.
2. Solo Motor Scooters: Except as specially authorised by the ACU, a 'Solo Motor Scooter' is a two wheeled motor vehicle on which the driver may sit on a seat and have free and open space in front of the seat for passage of his legs, with the following additional characteristics:
 - a). The minimum size of the space forward of the seat must be a regular or irregular trapezium with its top measuring 250mm along a line projected forward from the top of the seat parallel with a line drawn through the centres of the two road wheels and measured from the front extremity of the seat towards the steering column. Its depth vertically downwards must not be less than 250mm and its base not less than 100mm. The minimum space must be clear at all times of any obstruction of a permanent or temporary nature except where any such

- obstruction was fitted as manufacturer's original equipment (e.g. Vespa 90SS, Gilera Runner, Gilera DNA).
- b). The maximum permitted wheel rim size, where fitted as original equipment, shall not exceed 356mm/14 inches.
- c). It shall have been manufactured by a manufacturer recognised by the ACU and not less than one hundred machines of that type equipped with the manufacturer's original or optional equipment and must have been made and sold in the U.K. An Accountant's Certificate may be required as proof.
3. Engine: For the purpose of these regulations, the 'Engine' is deemed to comprise of the cylinder barrel, crankcase, side-casing and all internal components within the units.
 4. Forced induction: An engine shall be considered as having 'Forced Induction' when in respect of one engine cycle the total volume of induced gaseous mixture exceeds the capacity of the measured cylinder (measured geometrically).
 5. Original Equipment: As fitted by the machine manufacturer, as it left the production factory.
 6. Aftermarket Parts & Accessories: Parts manufactured by recognised business's intended solely for motor scooter use.
 7. Homologated/Homologation: Refers to the approval process 'commercially available parts' may have to go through before a Solo Motor Scooter can utilise them before competition use in any meeting or event sanctioned by both the ACU and BSSO.
 8. Commercially Available: All homologated/aftermarket parts must be commercially available to the general public either direct from manufacturers/distributors stock or to order.
 9. Standing Regulations: ACU National Sporting Code 3.02
 10. Supplementary Regulations: ACU National Sporting Code 3.03

15.3 GENERAL REGULATIONS

For the purposes of these Regulations and any events for which they are applicable, the regulations detailed herein section 15 are applicable in the first instance to ALL Solo Motor Scooters classes and machine types. Additional requirements or exclusions apply where they are specifically stated otherwise within a category of Solo Motor Scooter 'class specific' regulations.

For all regulation sections, in cases of doubt, misworded entries, grey areas, contradiction, exceptions or intent not expressed herein, the Technical Committee will refer to and uphold the 'Spirit of the Class' at all times.

NOTE: All shown Regulations must be cross referenced with the BSSO website (www.scooterracing.org.uk) for consideration of any subsequent updates not contained herein.

15.4 INCLINATION

It must be possible for the motor scooter, not being loaded, to be inclined to an angle of 26° from the vertical without any part of it, other than the tyres, coming into contact with the ground.

15.5 ENGINE POSITION

The engine must be positioned in the frame in an identical position and manner to that of the original motor scooter.

15.6 COMPOSITE OR MONOCOQUE CONSTRUCTION

The use of composite (i.e. skinned bonded honeycomb) or Monocoque construction is forbidden in all classes with the exception of those parts of the Motor Scooter which were so constructed as part of the manufacturer's original specification.

15.7 STEERING

Steering shall be through the front wheel only by means of non-adjustable handlebars securely fixed to the steering head of the motor scooter and having a MINIMUM overall width of 510mm.

The angle of rotation of the handlebars, measured horizontally at ground level to each side of a straight ahead position, must be a MINIMUM of 20° and steering stops must be fitted to limit angular movement to a MAXIMUM of 65° and/or to allow a MINIMUM clear space of 25mm between the handlebars and any part of the bodywork, tank or similar attachments. Whatever the position of the handlebars and suspension no part of the front wheel or forks must pass within 20mm of any bodywork or streamlining.

15.8 USE OF TITANIUM & OTHER EXOTIC MATERIALS

The use of TITANIUM and similar “exotic” metals is forbidden in the construction of the frame, front forks, handlebars/handlebar casing, swinging arm and wheel spindles in all classes.

15.9 MIRRORS

Rear view mirrors of any material are forbidden in all classes.

15.10 FRICTION LININGS, DISC PADS AND BRAKE HOSES

May be changed to allow for aftermarket, higher performance materials to be used.

15.11 STAND/SIDE STAND MOUNTING LUGS

May be removed.

15.12 THROTTLE CONTROLS

Throttle controls must be self-closing when not held by the hand.

15.13 CONTROL LEVERS

All handlebar levers must be ball-ended. The ball-end must be at least 19mm in diameter and be a permanently fixed integral part of the lever. Each control lever (both hand and foot) must be mounted on an independent pivot. Handlebar grips must be securely fixed to the ends of the handlebars.

15.14 PROJECTIONS

There shall be as few sharp projections as possible. Where there are projections, they must be covered in such a way as to prevent injury, occasioned by accidental contact, to the rider. All tubular ends must be securely fitted with rounded ends.

15.15 GLASS

All glass in lights must be removed and on instruments securely taped to retain it in place in the event of breakage. Where any glass is removed the exposed aperture must be securely covered or in-filled to retain the original appearance.

15.16 AIR INTAKES

Cooling air intakes, where permitted, must be so constructed that there is no forward projection/ protrusion to catch or foul in the event of an accident.

15.17 FUEL

Fuel must be from a roadside station forecourt with a maximum 100 octane rating. AVGAS 100 LL (low lead version only) can also be used with all relevant taxes paid. The use of specialist drum fuel, power/octane boosters or any kind of fuel additive other than two-stroke oil, is specifically prohibited. Fuel samples may be taken for analysis.

15.18 OIL DRAIN/FILLER PLUGS AND CATCH TANKS

All oil drain, level and filler plugs must be drilled and wired securely in position. Any oil breather

pipe fitted must discharge into a catch tank mounted in an easily accessible position and having a minimum capacity of 500ml. The catch tank must be empty at technical inspection.

15.19 ELECTRICAL SYSTEMS AND BATTERY

All machines must be fitted with an easily accessible ignition switch mounted in the vicinity of the handlebar/headset and within a radius of 200mm of the centre line of the top of the fork stem.

Switches must be of a positive locking type in both the on and off positions and when in the "OFF" position must not allow the engine to run. The "OFF" position of all switches must be prominently marked in capital letters of at least 10mm in height with dark coloured letters on a light background and vice versa. Any batteries fitted must be of a sealed type.

15.20 EXHAUSTS

Exhaust systems must fulfil all current ACU requirements concerning noise control. The systems must be constructed in a manner not prejudicial to the safety of the rider or any other competitor or official and be mounted in a safe manner. Exhaust fumes must not be discharged in a manner as to raise dust, foul the tyres or brakes or inconvenience any other rider. The furthest extremity of any exhaust pipe must not project beyond any part of the machine or its bodywork or streamlining; nor must the end of any exhaust pipe point upwards or downwards at an angle greater than 10° from the horizontal

15.21 LIQUID COOLING

Liquid cooling, where allowed, can only be through 'neat' water, no additives or inhibitors are allowed.

15.22 TYRES

Only treaded tyres designed manufactured as suitable for use on motor scooters will be permitted.

At pre-competition technical inspection all tyres must have a minimum depth of tread of 1.6mm remaining across the entire original tread area. The use of slick's, recut moulded tyres or any non-skid attachment to tyres is prohibited.

15.23 COMPULSORY ALTERATIONS

The following alterations must be made:

- a) Kick start pedals must be removed.
- b) Centre, side and prop stands, luggage carriers, mirrors and rear registration plates must be removed.
- c) Where an oil/fuel breather pipe is fitted the outlet must discharge into a catch tank located in an easily accessible position and which must be emptied before the start of the race.
- d) Engine bore & stroke must be clearly displayed in minimum 10mm high lettering and be positioned on the right hand side rear competition number plate or to the lower right hand side panel.

SECTION 16 TECHNICAL SPECIFICATIONS FOR MOTORSCOOTER SIDECAR COMBINATIONS (GROUP 7)

16.1 INTRODUCTION

These Regulations specify the requirements for construction of Motor scooter Combinations for use in Road Races, Sprints and Hill Climbs.

16.2 GENERAL

1. The sidecar must be placed on the left side of the motor scooter and the three road wheels must be disposed to give two tracks.

2. Hinged sidecars and steerable sidecar wheels are forbidden.
3. Neither the driver nor the passenger may be attached to the machine.

16.3 CONSTRUCTION

1. The frame must employ as part of its construction, the original type of engine fixing into the chassis giving effective support to the engine.
2. The remainder of the frame must be constructed of good quality seamless drawn steel tube of a circular or non-circular section, welded or brazed together. If circular, the outside diameter shall not exceed 100mm, if non-circular, the maximum cross section shall not exceed 100mm measured at right angles to any flat face.
3. The above does not restrict the swinging arm.
4. Reinforcement of the steering head is allowed to a maximum of 230mm from the centre line of the steering head.
5. Monocoque construction is forbidden.
6. The use of composite construction is forbidden with the exception of the sidecar platform. (i.e. Aluminium or carbon fibre skinned honeycomb).
7. The use of TITANIUM and similar "exotic" metals is forbidden in the construction of the frame, front forks, handlebars, swinging arm and wheel spindles. The use of light alloys is forbidden for wheel spindles.

16.4 DIMENSIONS

Weight: The MINIMUM weight, without fuel, shall be 130kg. The use of ballast to reach this weight is forbidden.

Width: The overall MAXIMUM shall be 1700mm.

Wheelbase: The MAXIMUM shall be 1650mm.

Track: The MINIMUM shall be 760mm. The distance is measured from the centre of the track left by the rear wheel to the centre of the track left by the sidecar wheel.

Ground Clearance: The MINIMUM clear space to be maintained beneath the entire under surface of the machine when loaded with fuel, driver and passenger is 65mm.

16.5 STREAMLINING AND BODYWORK

1. The streamlining must be easily detachable for technical control and be so designed and fitted to allow complete liberty of movement to the driver and passenger when the vehicle is in motion and when getting on and off the vehicle, without any part of it having to be displaced. The fairing may also be of the 'fully enclosed' type (as per ACU Formula 2 rules).
3. Rear view mirrors are forbidden.
4. A solid and effective protection must be fitted between the driver and the engine and must prevent direct contact between the driver's body or clothing and escaping flames or leaking fuel or oil.
5. Any type of seating may be used provided it is properly padded and securely fitted in place.
6. The extreme forward part of the streamlining must not project forward in plan beyond the most forward part of the front tyre by more than 400mm.
7. The extreme rearward part of the streamlining must not project rearward in plan beyond the most rearward part of the rear tyre by more than 400mm.
8. Whatever the position of the handlebars, there must be a clear space of at least 20mm between the streamlining and the extremities of the handlebars, including any attachments thereto, and a clear space of at least 20mm between the streamlining and any other part of the steering mechanism or front wheel.

16.6 PROJECTIONS

1. There shall be as few sharp projections as possible. Where there are projections, they must be

covered in such a way as to prevent injury, occasioned by accidental contact, to the driver and passenger.

2. All tubular ends must be securely fitted with rounded ends.

16.7 DRIVE GUARD

An adequate guard must be fitted to prevent the drive being accidentally touched. Drive chains must be guarded from sprocket to sprocket.

16.8 GLASS

All glass in lights and on instruments must be securely taped to retain it in place in the event of breakage.

16.9 AIR INTAKES

Cooling air intakes must be so constructed that there is NO forward projection/protrusion to catch or foul in the event of an accident.

16.10 ENGINE AND DRIVE UNITS

1. The engine and drive unit must have originated from a motor scooter and the drive must be transmitted to the road through the rear wheel of the motor scooter.
2. The unit shall be properly and safely finished with all necessary studs, nuts, bolts and washers securely fitted. There shall be no evidence of oil leaks. THE MAXIMUM PERMITTED ENGINE CAPACITY IS 260cc.
3. Any modifications made must not prejudice the safety of the driver, any other competitor or official and must be within the following parameters for the parts specified:
Cylinder Barrel(s) and Crankcase
 1. In regard to shape, size, configuration, position and number of ports, and external appearance, materials and method of manufacture, the cylinder barrel(s) must have originally conformed to the manufacturer's original specification (though not necessarily produced by the original manufacturer) or be included in the ACU list of approved kit barrels.
 2. The bore size of a cylinder may be increased by no more than 10mm.
 3. The cylinder used must have been originally designed for the engine type, must retain the original method and position of fitting and both the cylinder and the crankcase must retain the centres of the original stud holes used for bolting the cylinder to the crankcase. It must therefore be possible, with the exception of interference from a modified cylinder spigot, to fit the cylinder to a standard crank casing as produced by the original manufacturer of the engine unit used.
 4. The crankcase to cylinder gasket face must be parallel to that of the original crankcase.
 5. The crank casing must retain the original mounting points for support within the frame and the principal external dimensions must remain as manufacturer's original specification.
 6. Any modification to the crank casing to permit usage of modified original type crankshaft assemblies will not be permitted if the modification is so extensive as to preclude the fitting of the standard crankshaft as produced by the original manufacturer of the engine unit used.
 7. Modifications may be made to facilitate the use of water-cooling but the engine must comprise a single unit.
 8. Liquid cooling, or any other modification, to the cylinder will not be permitted if the modification is so extensive as to preclude identification of the origin of the cylinder.
4. GEARCASE/GEARBOX - The gearcase must be basically as the manufacturer's original specification. Modifications may be made to the number of drive ratios, the ratios themselves and to the gears. Alterations to the gear casing will not be permitted if the modification is so extensive as to preclude the fitting of a standard gear set as produced by the original manufacturer of the engine unit used.

Note: For the purposes of this Regulation, the 'engine' is deemed to comprise the cylinder barrel(s), crankcase and all internal components within these units.

16.11 ENGINE POSITION

The engine must be positioned behind the steering head and in front of the rear wheel and be so located that the centre line of the engine (by definition, a position midway between the centre lines of outermost cylinders) is no more than 160mm from the centre line of the rear wheel of the motor scooter.

16.12 INDUCTION SYSTEMS

Any form of induction system may be used with the exception of forced induction (see 13 below), which is prohibited.

16.13 FORCED INDUCTION

An engine shall be considered as having Forced Induction when in respect of one engine cycle, the total volume of gaseous mixture induced exceeds the capacity, measured geometrically, of the engine working cylinder(s). The intra-cylinder injection of fuel shall not be considered as forced induction.

16.14 FUEL

Fuel will be a maximum of a 100LL octane. The use of power boosters and/or octane boosters is specifically prohibited.

16.15 EXHAUST SYSTEMS

1. The exhaust systems must fulfil all the current ACU requirements concerning noise control.
2. The systems must be constructed in a manner not prejudicial to the safety of the driver, the passenger, or any other competitor or official. Exhaust fumes must not be discharged so as to raise dust, foul the tyres or brakes or inconvenience a passenger or any other driver.
3. The furthest extremity of any exhaust system must not project beyond any part of the machine or its bodywork or streamlining; nor must the end of any exhaust pipe point upwards or downwards at an angle greater than 10° from the horizontal.

16.16 FUEL TANK

1. The fuel tank(s) must be soundly constructed, entirely of metal, with a securely fitted filler cap, and sufficiently independently protected from the ground. The fuel filler cap must be fitted in such a way that it does not protrude from the fairing and cannot be torn off in an accident.
2. A fuel feed tap must be fitted in an easily accessible position and be prominently marked to indicate the "OFF" position.
3. Any fuel tank breather pipe must be fitted with a non-return valve and must discharge into a leak-proof catch tank having a minimum capacity of 500ml, which must be empty at technical control. All fuel pipes must be adequately secured.

16.17 OIL DRAIN/FILLER PLUGS AND CATCH TANKS

1. All oil drain, level and filler plugs must be tight and drilled and wired in position.
2. Any oil breather pipe fitted must discharge into a catch tank mounted in an easily accessible position and having a minimum capacity of 500ml.
3. The catch tank must be empty at technical control.

16.18 STEERING

1. Steering shall be through the front wheel only by means of handlebars firmly secured to steering members turning the front wheel and its supports directly with no intermediate push or pull rods.

2. Hub centre steering, remote steering linkages and the use of articulated joints in the steering mechanism are not permitted. By definition an articulated joint is one allowing movement in more than one plane.
3. Handlebars and all steering bearings must be located on the sprung portion of the front suspension. The extreme width of the handlebars must be not less than 450mm.
4. The minimum angle of rotation of the handlebars, each side of a straight ahead position and measured horizontally at ground level, is to be 30° and stops must be fitted in order to limit angular movement to 65° and to allow a minimum of 20mm clearance between the handlebars and any tank, similar attachments or streamlining.
5. Whatever the position of the handlebars and suspension no part of the front wheel or forks must pass within 20mm of any bodywork or streamlining.
6. It is permissible to displace the steering head up to a maximum of 75mm determined by measuring the off set from the centre line of the rear wheel.

16.19 WHEELS AND TYRES

1. All wheels must be of metal construction and be within an allowance of 5° from the vertical.
2. The diameter of any fully inflated tyre, measured over the outside of the tyre, shall be NOT LESS THAN 407mm and NOT MORE THAN 560mm.
3. At technical control ALL moulded tread tyres must have a minimum depth of tread of 1.6mm across the entire original tread area. Recut moulded tyres are not permitted.
4. When conditions permit, slick (untreaded) tyres may be used and these may be professionally grooved. The surface of the slick tyre must contain three or more hollows at 120-degree intervals or less, indicating the limit of wear on the centre and shoulder areas of the tyre. When at least two of these indicator hollows become worn on different parts of the periphery, the tyre must no longer be used.

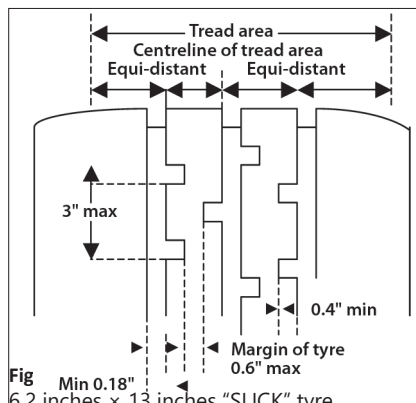

Fig 6.2 inches x 13 inches "SLICK" tyre with a rolling diameter of 19.8 inches

$$\frac{TTD = 3.142 \times 19.8}{3} = \frac{62.203}{3} = 20.734$$

5. Intermediate Pattern Types. For wet weather conditions which call for a "TREADED" tyre other than a full "WEAR" tyre, an "INTERMEDIATE" pattern tyre must be used. The tyre pattern must be professionally cut and consist of a minimum of three circumferential grooves each 0.18 inches in width. The depth may be cut to show the canvas, but must never sever the canvas fibres.

Note: At technical control the surface of the tyre must contain three or more hollow "WEAR" indicators at 120 degree intervals indicating the limit of wear across the tread area.

One groove must be cut in the centre of the tread area, with the remaining grooves located equidistant between the centre groove and the edge of the tread area. In addition to the circumferential groove, "SLITS" across the tread area must be cut from each groove, 0.18 inches in width, 0.4 inches minimum in length. Spacing must be equidistant around the periphery of the tyre and no more than 3 inches apart.

To give inter groove relationship between the "SLITS"; their position must be staggered. The margin of tyre surface between the ends of the opposed "SLITS" must be no greater than 0.6 inches.

See FIGURE 1 for example calculation and a diagrammatic explanation of the above dimensions.

16.20 FRONT SUSPENSIONS

The front suspension is to be either a leading or trailing fork, or links, with the wheel equally supported on each side. Wishbones are not permitted.

16.21 REAR SUSPENSION

The rear suspension, if fitted, is to be of the swinging arm type. A single sided swinging arm is allowed.

16.22 BRAKES

The braking system must consist of at least two brakes operated independently on the front and rear road wheels, each giving complete control. Braking of the sidecar wheel is optional.

16.23 MUDGUARDS AND WHEEL PROTECTION

1. The rear wheel mudguard must cover at least 240 degrees of the rear wheel. The side nearest to the sidecar wheel must be enclosed.
2. The sidecar wheel must be enclosed from the sidecar platform and level with the sidecar platform around the periphery.
3. For rear exit sidecars the sidecar wheel must be totally enclosed down to platform level.

16.24 DRIVER

1. The driver in the normal driving position must be completely visible, with the exception of his forearms and lower legs, from the side opposite to the sidecar and from above.
2. It is forbidden for the driver's legs to be enclosed. The driver's position must be such that the driver's feet are positioned behind the knees when viewed from above and the footrests so designed and positioned that easy access is always available to any control pedal.

16.25 PASSENGER

The passenger must be able to lean out to either side of the sidecar. For this purpose the vehicle must be fitted with suitable handholds, which must be of the "closed loop" type.

16.26 ELECTRICAL SYSTEMS AND BATTERY

1. All vehicles must be fitted with an easily accessible ignition switch, mounted in the vicinity of the handlebar/headset and within a radius of 200mm of the centre line of the top of the fork stem.
2. Switches must be of a positive locking type in both the on and off positions and when in the "OFF" position must not allow the engine to run. The "OFF" position of all switches must be prominently marked in capital letters of at least 10mm in height with dark coloured letters on a light background and vice versa.
3. Any electric fuel feed pump must be wired in such a way as to cut out when the ignition switch is in the "OFF" position.
4. Batteries, if fitted, must be of the leak-proof type.

16.27 THROTTLE CONTROLS

Throttle controls must be self-closing when not held by the hand.

16.28 CONTROL LEVERS

1. All handlebar levers must be ball ended, the ball to be at least 19mm in diameter and to be a permanently fixed integral part of the lever.
2. Each control lever (both hand and foot) must be mounted on an independent pivot.
3. Handlebar grips must be securely fixed to the ends of the handlebars.

SECTION 17 TECHNICAL SPECIFICATIONS FOR FORMULA 125 MOTORSCOOTER SIDECAR COMBINATIONS

Unless specifically mentioned in these Regulations the Standing Regulations for the construction of Group 7 Motor Scooter Regulations detailed above shall apply.

17.1 CONSTRUCTION

1. The frame must be of good quality drawn steel tube of circular or non-circular section, welded or brazed together. If circular the outside diameter must not exceed 100mm. If non-circular the maximum cross section shall not exceed 150mm. measured at right angles to any flat surface.
2. The above does not restrict the swinging arm. The use of composite construction is forbidden with the exception of the sidecar platform, i.e. Aluminium or carbon fibre honeycomb.
3. The use of Titanium or other similar 'exotic' materials in the construction of the frame, forks, handlebars, swinging arm and wheel spindles is forbidden.

17.2 DIMENSIONS

Width: The overall maximum shall be 1524mm (60") measured over the extremities of the streamlining.

Wheelbase: The maximum shall be 1829mm (72") measured between the centres of the front and rear wheels.

Track: The minimum shall be 760mm. The maximum shall be 1170mm. The track being the distance measured between the rear and sidecar wheel, the point of measurement being at right angles to a line drawn between the centre line of the front and rear wheels of the combination and a line at right angles passing through the sidecar wheel.

Ground clearance: The minimum clear space to be maintained beneath the entire under surface of the machine when loaded with fuel, driver and passenger must be 65mm.

17.3 STREAMLINING AND BODYWORK

1. This must be easily detachable for technical control purposes and be so designed and fitted to allow complete liberty of movement to the driver and passenger when the vehicle is in motion and when getting on and off the vehicle without any part of the streamlining being displaced.
2. Fairings and Rear view mirrors are allowed.
3. A solid and effective protection must be fitted between the driver and the engine to prevent direct contact between the driver's body or clothing from escaping flames or leaking oil.
4. Any type of seating may be used provided it is properly padded and securely fitted in place.
5. The extreme forward part of any streamlining must not project forward in plan beyond the most forward part of the front tyre by more than 400mm.
6. The extreme rearward part of the streamlining must not project rearward in plan beyond the most rearward part of the rear tyre by more than 400mm.

17.4 DRIVEGUARDS

A metal guard must be fitted to prevent accidental contact with the chain or sprocket. Drive chains must be guarded from sprocket to sprocket.

17.5 ENGINE AND DRIVE UNITS

1. Permitted engine: 125cc. i.e. Aprilia.
2. Drive must be transmitted to the road through the rear wheel of the machine.
3. The engine unit must be properly and safely finished, all studs, bolts, nuts and washers fitted securely in place.
4. There shall be no evidence of oil leaks.
5. Any modifications made to the engine unit must not prejudice the safety of the driver and

passenger or other competitor or official and must be within the specifications of the engine and drive unit regulations.

6. Cylinder Barrel and Crankcase

1. In regard to the shape, size, configuration, position and number of sports, external appearance, materials and manufacture, the cylinder barrel must conform to the manufacturers original specification (though not necessarily produced by the same manufacturer).

2. The bore size of a cylinder may be increased.

3. The cylinder used, must have been originally designed for the engine type, must retain the original method and position of fixing, (the number and position of studs in the crankcase at the gasket face must be as manufacturers original specification).

4. The crankcase to cylinder gasket face must be parallel to that of the original crankcase. The crankcase porting may be altered.

5. The crankcase must retain the original mounting points, which must be used to support the engine in the frame.

External dimensions of the crankcase must remain as manufacturers original specification.

6. The Crankshaft must remain as the manufacturers original specification, although the connecting rod may be modified or substituted.

7. Alternative pistons may be used to change the characteristics of the engine. The cylinder barrel gasket faces may be machined to allow for the difference in compression height of the piston used.

8. Liquid cooling of the engine case will not be permitted.

17.6 ENGINE POSITION

The engine must be positioned between the steering headstock and the rear wheel.

17.7 INDUCTION SYSTEMS

Any form of induction system may be used with the exception of superchargers.

17.8 FUEL – UNLEADED

1. A fuel tank with a breather pipe must be fitted with a non-return valve and discharge into a minimum of 500ml. catch bottle.
2. Fuel must be commercially available brand of petrol, as supplied from a wayside petrol station. (Aviation fuel, Avgas, is not included).
3. No additives other than lubricants are permitted, (power boosters, octane boosters are prohibited).

17.9 STEERING

1. Steering will be through the front wheel only, by means of handlebars with a minimum width of 450mm.
2. The minimum angle of rotation of the handlebars each side of the straight-ahead position must be 30°, stops must be fitted to limit the angular movement of the handlebars to 65°. Whatever the position of the handlebars and suspension, no part of the front wheel or forks must pass within 20mm of any bodywork or streamlining.
3. It is permissible to displace the steering head up to a maximum of 75mm determined by measuring the off set from the centre line of the rear wheel.
4. Machines with off set steering heads must maintain two tracks.

17.10 WHEELS AND TYRES

1. All wheels rims must be of metal construction and a maximum diameter of 407mm.
2. The wheel when fitted in position must rotate within 5° of the vertical plane.

3. At technical control all moulded treaded tyre must have a minimum of 1.6mm. of tread across the entire original tread area. (recut moulded tyre are not permitted).
4. Sidecar wheels may be Kart type 'slick' tyre, the surface of the tyre must contain three or more wear indicators positioned at 120° around the tyre circumference.
5. When at least two of these become worn on different parts of the tyre, the tyre may no longer be used.
6. Wheel spindles must pass through the fork legs/swinging arm assemblies which must provide a positive location for the spindle when assembled, split pin locking and/or nylon locking nuts must be used to prevent the axle coming lose.

17.11 REAR SUSPENSION

1. The rear suspension, if fitted is to be the swinging arm type. Movement of the arm i.e. for the purpose of chain adjustment can be by means of eccentric cams.

Note: any adjustment used must not allow the wheelbase to exceed the maximum permitted dimension.

SECTION 18 TECHNICAL SPECIFICATIONS FOR CLASSIC (GROUP 8) MOTORSCOOTER SIDECAR COMBINATIONS

Unless specifically mentioned in these Regulations the Standing Regulations for the construction of (Group 7) Motor Scooter Regulations detailed above shall apply.

18.1 INTRODUCTION

These Regulations specify the requirements for construction of Classic Motor scooter Combinations for use in Road Races, Sprints and Hill Climbs.

18.2 CONSTRUCTION

1. The chassis must incorporate, as an integral part, the complete Lambretta spine frame including engine mountings.
2. The remainder of the chassis must be constructed of good quality seamless drawn steel tube of acircular or non-circular section, welded together.
3. Reinforcement of the steering head is allowed to a maximum of 230mm from the centre line of the steering head.
4. The use of composite construction is forbidden with the exception of the sidecar platform. (i.e. Aluminium or carbon fibre skinned honeycomb).
5. The use of TITANIUM and similar "exotic" metals is forbidden in the construction of the chassis, front forks, handlebars and wheel spindles. The use of light alloys is forbidden for wheel spindles.

18.3 DIMENSIONS

Width: The overall MAXIMUM shall be 1520mm.

18.4 STREAMLINING AND BODYWORK

1. The streamlining must be easily detachable for technical control and be so designed and fitted to allow complete liberty of movement to the driver and passenger when the vehicle is in motion and when getting on and off the vehicle, without any part of it having to be displaced.
2. Aerofoils or spoilers are not permitted.
3. Rear view mirrors are forbidden.
4. A solid and effective protection must be fitted between the driver and the engine and must prevent direct contact between the driver's body or clothing and escaping flames or leaking fuel or oil.
5. Any type of seating may be used provided it is properly padded and securely fitted in place.

6. The extreme forward part of the streamlining must not project forward in plan beyond the most forward part of the front tyre by more than 400mm.
7. The extreme rearward part of the streamlining must not project rearward in plan beyond the most rearward part of the rear tyre by more than 400mm.
8. Whatever the position of the handlebars, there must be a clear space of at least 25mm between the streamlining and the extremities of the handlebars, including any attachments thereto, and a clear space of at least 20mm between the streamlining and any other part of the steering mechanism or front wheel.

18.5 ENGINE AND DRIVE UNITS

1. The engine and drive unit must have originated from a Lambretta motor scooter.
2. The unit shall be properly and safely finished with all necessary studs, nuts, bolts and washers securely fitted. There shall be no evidence of oil leaks.
3. The MAXIMUM PERMITTED bore is 70mm. The MAXIMUM PERMITTED stroke is 60mm.
4. Any modifications made must not prejudice the safety of the driver, any other competitor or official and must be within the following parameters for the parts specified:
 5. CYLINDER HEAD – Liquid cooling is not permitted.
 6. CYLINDER BARREL – Cylinder barrel must be as manufacturer's original specification either a TS1 or RB22 kit barrel.
 7. PORTS – Ports may be enlarged, but they may not be bridged nor the cylinder barrel slotted. The position may not be changed, additional ports may not be provided, and the provision of additional material on either the inside or the outside of the barrel is prohibited.
 8. PACKING PIECES – The total thickness of any packing piece(s) or gasket(s) used between the base of the cylinder and the crankcase must not exceed 10mm. Packing pieces may not be used as a means of increasing the available port area.

18.6 CRANKCASE

Crank casing must be as manufacturer's original specification, except that:

1. Modifications may be made to permit the use of a larger section tyre subject to the limitations in Regulation 18 below.
2. Modifications may be made to any existing crankcase porting except that the provision of additional material on either the inside or the outside of the casing is prohibited.
3. Notwithstanding the exception in B above, the provision of additional material to effect genuine repairs to a crankcase will be permitted provided that the final dimensions and appearance do not exceed the manufacturer's original specification.

18.7 CRANKSHAFT

The crankshaft must be a commercially available type designed to fit a Lambretta motor scooter with a MAXIMUM permitted stroke of 60mm and shall remain as manufacturer's original specification, except:

1. The ignition mounting may be altered.
2. The crankshaft may be "padded".

18.8 GEARCASE

1. The gearcase must be as manufacturer's original specification except that a spacer may be used to facilitate the use of extra clutch plates.
2. The gearbox must be as manufacturer's original specification for the engine type, except that the original gear cluster may be altered to provide alternative ratios. The number of ratios must remain unchanged.

Note: For the purposes of this Regulation, the 'engine' is deemed to comprise the cylinder barrel(s), crankcase and all internal components within these units.

18.9 ENGINE POSITION

The engine unit must be in the original position.

18.10 INDUCTION SYSTEMS

The engine shall be normally aspirated.

18.11 WHEELS AND TYRES

1. All wheels must be of metal construction and be within an allowance of 5° from the vertical.
2. The diameter of the front and sidecar wheels MUST be 10 inches and the tyres thereon have a MAXIMUM section of 5J. The diameter of the rear wheel MUST be 10 inches with a wider section standard pattern rim permissible and allowing a MAXIMUM tyre size of 10 inches by 4.00.
3. At technical control ALL tyres must have moulded treads and must have a minimum depth of tread of 1.6mm across the entire original tread area. Recut moulded tyres are not permitted.

18.12 REAR SUSPENSION

Rear suspension is not permitted.

18.13 CONTROL LEVERS

1. All handlebar levers must be ball ended, the ball to be at least 19mm in diameter and to be a permanently fixed integral part of the lever. Each control lever (both hand and foot) must be mounted on an independent pivot. Handlebar grips must be securely fixed to the ends of the handlebar.

The following information does not form part of the Standing Regulations but is provided as a quick guide to the requirements of the SRs.

It is hoped, by the promoters of this class, that this limited specification will enable close racing at an affordable cost. For the benefit of all who compete in the class, cheating will not be tolerated.

1. Complete Lambretta spine frame.
2. Engine in original position driving the rear wheel.
3. Lambretta cast iron or TS1 barrel.
4. No water-cooling for head or barrel.
5. Porting to Standard class specification, i.e. no bridged ports or extra ports.
6. Maximum stroke 60mm. Maximum bore 70mm.
7. No 'alloy' welding of barrels.
8. Passenger exit can be in front of or behind the sidecar wheel, whichever is preferred.
9. The use of titanium or similar 'exotic' material is forbidden.
10. Treaded tyres only at all times.
11. Front and sidecar wheels 10 × 5J maximum.
12. Rear wheel must be standard pattern rim or wide version with 4.00 × 10 maximum scooter tyre.
13. Maximum chassis dimensions – wheelbase 1650mm – width 1520mm. Track – minimum 760mm. Ground clearance when fully loaded – 65mm.
14. Centre hub steering and sidecar wheel steering is forbidden.
15. Independently operated brakes on front and rear wheels – sidecar brake is optional.

section

ACU HISTORICAL INFORMATION
CHAMpIONS

ACU historical information

ACU pATRON

HRH The Prince Philip,
Duke of Edinburgh, KG, KT, OM, GBE,
AC, QSO, PC 1952–
Present
HRH The Duke of York, KG KT 1935

ACU pPRESIDENT EMERITUS

The Rt Hon The Lord Jopling, DL 2004–
Present

ACU pPRESIDENT

The Rt Reverend John Oliver 2009–2017
Lt. Col (Ret'd) E. P. Bartlett 2004–2008
The Rt Hon The Lord Jopling, DL 1990–2003
Sir Hector Monro, AE, JP, DL, MP 1984–1989
The Most Honourable The Marquess
Camden, DL, JP 1966–1983
The Rt Hon. Lord Brabazon of
Tara, GBE, MC, PC 1948–1964
The Hon. Sir Arthur Stanley, GBE,
CB, MVO 1947–1948

ACU HONORARY VICE pPRESIDENT

Lt. Col (Ret'd) E. P. Bartlett
Mrs M. Mellish 2016–
Present

ACU VICE pPRESIDENT

T. Fairbrother 2016–Present
C. Moram 1992–Present
D. Ryder 2017–Present
D. Willoughby 2017–Present
Mrs M. Mellish 2008–2015
A. Ackland 2001–2006
M. G. Francis 1997–1998
D. Clampin 1996–1998
K. Lywood 1996–1998
G. Hadfield 1994–1999
K. Sprayson 1994–1998
K. Blampied 1991–1999
R. B. Bower 1991–1994
J. Bussell 1990–1991
F. Hanks 1989–2000
L. C. Courney 1988–1989
A. J. Pendergast 1988–1994
B. E. Woods 1986–1987
1994

E. A. Woods 1984–1994
F. E. G. Vigers 1983–1985
G. E. Padley 1982–1992
R. G. Owen 1980–1987
C. Wilkinson 1981–1989
H. E. Jones 1980–1985
L. H. Davis 1980–1983
J. N. Anelay 1978–1996
V. Cooper 1974–1982
E. G. Cope 1974–1990
W. E. Swann 1970–1980
L. J. Archer 1970–1973
N. Goss, MBE 1970–1999
J. McNulty 1970–1979
J. E. Sutton 1968–1976
J. E. Whitaker 1957–1966
A. Jefferies 1955–1978
H. S. Perrey 1955–1978
E. Damadian 1953–1983
N. E. Dixon, MBE 1953–1983
J. C. Lowe 1953–1969
T. E. Ryan 1951–1985
C. H. King 1951–1981
H. P. Baughan 1949–1968
P. S. Chamberlain 1949–1954
Mrs M. L. Anning 1949–1950

J. R. Greene 1947–1950
Mrs D. Dornie 1945–1997
J. A. L. Ball 1944–1986
G. R. Allan 1946–1962
V. C. Anstice 1939–1969
H. W. Robinson 1939–1952
A. Taylor 1939–1939
G. Smith 1938–1938
J. D. Woodhouse 1937–1961
B. Marians 1937–1952
T. W. Monkhouse 1933–1939
Major J. R. Potter 1933–1935
E. W. Winckle 1933–1935
Major R. V. C. Brook 1932–1938
E. Featherstone 1932–1938
J. M. Noaks 1931–1948
Lt Col M. O'Gorman 1927–1933
Professor A. M. Low, A.C.G.I. D.Sc. 1925–1956

The Rt. Hon Lord Brabazon of	
Tara, P.C, M.C.	1925-1947
H. P. E. Harding	1925-1952
E. P. Greenhill	1925-1939

Col. F. Lindsay Lloyd, C.M.G.	1925–1939
W. H. Wells, M.I.A.E.	1925–1933
A. G. Reynolds	1925–1935
J. W. G. Brooker	1925–1933
Col A. E. Davidson, DSO	1925–1933
Brig Sir H. Capel Holden	1925–1933
Sir J. Orde	1925–1929
Lt Col F. S. Brereton, CBE	1925–1926

ACU CHAIRMAN

J. R. Humphrey	2019–Present
J. Collins	2017–2018
B. Higgins	2011–2016
J. Parker	2004–2010
Lt. Col (Ret’d) E. P. Bartlett	1997–2003
W. S. Rawlinson	1993–1996
K. J. Lywood	1992–1992
W. A. Smith	1988–1991
N. E. Goss	1982–1987
N. E. Dixon, MBE	1957–1981
Prof A. M. Low	1932–1956
Major J. R. Potter	1926–1931
Lt. Col F. S. Brereton, CBE	1921–1925
Lt. Col A. E. Davidson	1920–1920
J. R. Nisbet	1914–1919
R. Todd	1903–1913

HONORARY MEMBERS OF THE BOARD OF DIRECTORS, SpORT COMMITTEES AND pANELS

F. C. Carter Honorary Deputy Chairman	2009–2018
A. F. G Noel Honorary Chairman Track Racing Committee	2009–2018
J. Parker Honorary Member of the Board	2011–2013
J. Parker Honorary Member of the Road Race, Drag & Sprint Committee	2012–2013

ACU HONORARY MEMBERS SINCE 2000

C. Armes	2002–2012
D. D. Banks	2008–
Lt. Col (Ret’d) E. P. Bartlett	2009–
E. Bellars	2011–
K. A. R. Blampied	2001–2006
A. Brownlie	2001–
J. Bussell	2005–2015
J. Cadogan	2002–
F. Carter	2010
	2018
	–
D. R. Clampin	2001–2017
J. Coles	2008–
R. Collins	2011–
Dr J. Ehrlich	2000–2001
W. Evans, MBE	2018–
T. Fairbrother	2014–
M. Francis	2008–
N. E. Goss, MBE	2001–2011
E. Jones	2014–
K. Lywood	2008–2016
Miss P. Miller	2005–2006
T. Noel	2018–
A. Penny	2019–
F. J. Rendell	2001–2004
D. Ryder	2006–
D. Slaughter, MBE	2009–2019
R. W. Smith	2001–

W. A. Smith	2008–
K. Sprayson	2003–
J. Stone	2008–

ACU MEDAL OF HONOUR

Eric Adcock	2011
Graham Archer	2016
Vic Ashford	2011–2012
David Brown	2019
Ron Carter	2009
Tony Clarke	2014
Brenda Clarke	2014
Colin Dommett	2012
Wyn Evans	2013
Graham Harrison	2019
John Lightfoot	2010
Jack Parker	2009
Brian Valder	2016
Brian Webster	2012
John White	2012

WORLD & EUROPEAN CHAMPIONS

ROAD RACING

FIM World Superbike Championship 3rd

Alex Lowes

FIM World Sidecar Champions

Tim Reeves, Mark Wilkes

FIM World Sidecar Championship 3rd

Ben Birchall, Tom Birchall

FIME Drag Bike Superstreet Bike Cup Champion

Steve Venables

FIME Drag Bike Junior Cup Champion

Blade Dummer

FIME Vintage Road Racing Champion Class 3

David Whitehouse

FIME Vintage Road Racing Champion Class 4

Pete Boast

FIME Vintage Road Racing Champion Class 7B

Richard Peers-Jones

FIME Vintage Road Racing Champion Class 9A

Rob Wittey

FIME Vintage Road Racing Champion Class 9B

Peter Howarth

FIME Vintage Endurance European Cup Open Champion

Parts Europe Team – Dave Crampton, Chris White

TRIALS & ENDURO

FIM Womens Trial des Nations 2nd

Emma Bristow, Jess Bown, Donna Fox

FIM Womens Trial World Champion

Emma Bristow

FIM Womens Trial World Cup 2nd

Alice Minta

FIM World X-Trial Des Nations 3rd

Jack Price, Toby Martyn

FIM World Enduro GP Champion

Bradley Freeman

FIM World Enduro GP Championship 2nd

Steve Holcombe

FIM World Enduro GP Championship 3rd

Daniel McCanney

FIM World Enduro E1 Class Champion

Bradley Freeman

FIM World Enduro E2 Class Championship 3rd

Joe Wootton

FIM World Enduro E3 Class Champion

Steve Holcombe

FIM World Enduro E3 Class Championship 2nd

Danny McCanney

FIM Womens World Enduro Cup

Jane Daniels

FIM World Enduro Open 4T Cup

Tom Ellwood

FIM World Enduro Open Senior Cup

David Knight

FIM World Super Enduro Junior Cup

William Hoare

ISDE AWARDS

Womens Team 3rd

Jane Daniels, Nieve Holmes, Rosie Rowett

Meeten Award

Danny McCanney

Tim Ward Award

Frazer Norrie

Arthur Prince

Award **Danny**

McCanney

Welsh Motorcycle Foundation Award

Hafren Dirt Bike Club – Charlie Evans, Robert Jones, Ioan Jones

FIM EUROPE AWARDS

FIME European Youth Trial Championship 2nd

Jack Dance

FIME European Youth Trial Championship 2nd

Ben Dignan

FIME Enduro Championship 2nd

Jed Etchells

FIME Enduro Junior U23 Champion

Jed Etchells

FIME Enduro 250 2T Championship 3rd

Luke Parker

FIME Womens Enduro Championship 2nd

Nieve Holmes

MOTOCROSS

FIM MX of Nations 3rd

Nathan Watson, Adam Sterry, Shaun Simpson

– **Mark Chamberlain (TM)**

FIM World Junior Championship 3rd
65cc **Ashton Boughen, Brandon Buckley, Reece Jones, Archie Jay-Girdham, Charlie Richmond**
85cc **Kiean Boughen, Ollie Colmer, Finley Evans, Charlie Heyman, Bailey Johnston**
125cc **Buster Hart, Louie Kessell, Joel Rizzi, Eddie Jay Wade, Preston Williams**
FIME EMX2T Championship 2nd
Brad Anderson
FIME EMX2T Championship 3rd
Todd Kellett
FIME Quad Championship 3rd
Harry Walker
FIME Sidecar cross of Nations 3rd
Stuart Brown, Josh Chamberlain, Jake Brown, Joe Millard, George Kinge, Lewis Gray – Dan Chamberlain (TM)

TRACK RACING

FIM Team Under 21 2nd
Robert Lambert, Daniel Bewley, Drew Kemp, Kyle Bickley, Leon Flint
FIM 125cc World Gold Trophy Champion
Max Perry
FIM 125cc World Gold Trophy
Championship 2nd
Luke Harrison
FIME Individual Grass Track Champion
Zach Wajtknecht
FIME Individual Grass Track Championship
2nd
Paul Hurry
FIME Sidecar Grass Track Championship 3rd
Mitch Godden, Paul Smith
FIME 125cc Youth Track Racing Cup 3rd
Luke Harrison

BRITISH CHAMPIONS

MOTOCROSS CHAMPIONS

Maxxis ACU British MX1 Champion
Tommy Searle
Maxxis ACU British MX2 Champion
Dylan Walsh
Maxxis ACU MX2 Youth Champion
Joel Rizzi
ACU British Expert MX1 Champion
Jake Millward
ACU British Expert MX2 Champion
Ashton Dickinson

ACU British Two Stroke Open Champion
Brad Wheeler
ACU British Two Stroke 125cc Adult Champion
James Cottrell
ACU British Two Stroke Evo Champion
George Gough
ACU British Two Stroke Super Evo Champion
Billy MacKenzie
ACU British Quad Cross Champion
Mark McLernon
ACU British Under 21 Quad Champion
Harry Walker
ACU British Quad Masters Champion
Ed Davies
ACU British Quad Cross Clubman Champion
Gary Atkinson
ACU British Quad Cross Ladies Champion
Catrin Davies
Maxxis ACU British Sidecar Cross Champions
Stuart Brown, Josh Chamberlain
ACU National Expert Sidecar Cross Champions
Tony Grahame, Charlie Ide
ACU Sidecar Clubmans Champions
James Georges, Chris Simpson

Judd KTM ACU British Youth National MX
Champions
Open **Max Ingham**
125cc **Preston Williams**
85cc Big Wheel **Charlie Heyman**
85cc Small Wheel **Tyla Hooley**
65cc **Reece Jones**
Auto **Robbie Daly**

ACU British Youth 250cc Quad Cross
Champion
Robbie Wood
ACU British Youth 100cc Quad Cross
Champion
Connor Yates

TRIALS CHAMPIONS

ACU RT Keedwell TrialGB British Champion
Jack Price
ACU RT Keedwell Trial2 British Champion
Ross Danby
ACU RT Keedwell Trial125 British Champion
Ben Dignan

ACU RT Keedwell Expert British Champion
Christopher Stay

ACU Belle Trailers British Solo Youth
Trials Championship
Class A **Jack Dance**
Class B **Harry Turner**
Class C Standard Wheel **George Hemingway**
Class C Medium Wheel **Elliot Smith**
Class D Medium Wheel **Max Dance**
Class D Small Wheel **Mason Crawford**

ACU Belle Trailers British Ladies and Girls
Champions
Ladies Champion **Jess Bown**
Ladies 50/50 Champion **Chloe Baker**
Ladies Intermediate Champion **Charlotte
Kimber**
Girls Class 50/50 **Sarah Bell**
Girls Class A Intermediate **Amy Clark**
Girls Class B **Kaytlyn Adshead**
Girls Class C **Matilda Arbon**
Girls Class D **Daisy Criag**

ACU British Super Trial Champion
James Dabill
ACU British Womens Super Trial Champion
Emma Bristow

ACU S3 Parts National Trials Champion
Dan Thorpe
ACU S3 Parts Clubman Trials Champion
Richard Fraser
ACU S3 Parts National Trials Best 125cc
Champion
Jake Eley
ACU S3 Parts National Trials Over 40s
Champion
Phil Houghton

ACU Wessex Plant Hire (Bristol) British
Sidecar Trials Champions
John Tuck, Matt Sparkes
ACU Wessex Plant Hire (Bristol) British
Intermediate Sidecar Trials Champions
Jack Corlett, Beth Thomas
ACU Wessex Plant Hire (Bristol)
British Clubmans Sidecar Trials
Champions **John Corlett, Jamie Howell**

ACU Wessex Plant Hire (Bristol) British
Sidecar Trials Best Newcomer
Neil Franks, Mike Franks

ACU Normandale Traditional Trials
Championship
Class 1 Over 40 **Jason Galvin**
Class 2 Over 50 **Ian Wakeford**
Class 3 Over 60 **Mick Marshall**
Class 4 Air Cooled Monoshock **Rob Sherlock**
Twinshock **Steve Hitchcock**

ACU Trail Bike Championship
Chris Koch

ENDURO CHAMPIONS

ACU British Enduro Solo Champion
Danny McCanney
ACU British Enduro E1 4 Stroke Champion
Alex Walton
ACU British Enduro E2 Champion
Jack Edmondson
ACU British Enduro E3 Champion
Danny McCanney
ACU British Enduro U23 Junior Champion
Dan Mundell
ACU British Enduro U23 Junior Expert
Champion
Aaron Gordon
ACU British Enduro Expert Champion
Aaron Gordon
ACU British Enduro E1 2 Stroke Expert
Champion
Henry Yardley
ACU British Enduro E1 4 Stroke Expert
Champion
Roger Holland
ACU British Enduro E2 Expert Champion
Aaron Gordon
ACU British Enduro E3 Expert Champion
Craig Norrey
ACU British Enduro Clubman Champion
James Palmer
ACU British Enduro E1 2 Stroke Clubman
Champion
James Palmer
ACU British Enduro E1 4 Stroke
Clubman Champion
Ross Kerr
ACU British Enduro E2 Clubman Champion
Joshua Kirby

ACU British Enduro E3 Clubman Champion

Darren Kiff

ACU British Enduro Over 40s Enduro
Champion

Andrew Edwards

ACU British Enduro Over 50s Enduro
Champion

Richard Hay

ACU British Enduro Womens Expert
Champion

Jane Daniels

ACU British Enduro Womens Clubman
Champion

Ellie Cooke

British ACU Sidecar Enduro Champions

Jonathan Williams, Neil James

British ACU Sidecar Enduro Expert
Champions

Mark Stokes, Luke Townsend

ACU Sidecar Enduro Clubmans Champions

James Cuff, Andy Scrivens

ACU Classic Enduro Expert CE1 Champion

Ian Barnett

ACU Classic Enduro Clubman CE1 Champion

Philip Smith

ACU Classic Enduro Expert CE2 Champion

Manuel Bernardez

ACU Classic Enduro Clubman CE2 Champion

Peter King

ACU British Sprint Enduro Championship

Championship **Jack Edmondson**

Expert **Max Ditchfield**

Clubman **James Palmer**

Veteran **Anthony Dean**

Sportsman **Tobias Sammut**

Ladies **Ellie Cooke**

Youth **Adam Jones**

ACU British Extreme Enduro Championship

Pro **Jonny Walker**

Expert **Jack Spencer**

Clubman **Jason Hirst**

Sportsmen Veterans **Alex Owen**

Elite Veterans **Harold Crawford**

Youth **Richard Moorhouse**

ACU British Supreme Enduro Champion

Jack Edmondson

ROAD RACE CHAMPIONS

ACU Junior Cup Champion

Ash Barnes

ACU GP250cc National Champion

James Hind

ACU Post Classic Champion

Lee Hodge

ACU 500cc Classic Champion

Joe Barton

ACU 50cc Champion

Stephen Graves

ACU Girder Forks Champion

Mervyn Stratford

ACU National Endurance 1000cc Champions

**Cunnington Racing – Joe Collier, Luke Hedger,
Liam Murtagh**

ACU National Endurance 600cc Champions

**Pertemps Network Racing – Gaz Evans, Jane
Nixon, Colin Norris**

ACU/FSRA British FII Sidecar Champions

Peter Founds, Jevan Walmsley

ACU/FSRA British FII Sidecar Cup Champions

Simon Robinson, Mick Fairhurst

BRITISH SCOOTER CHAMPION

Scooter

Stock **Justin**

Price Super

Scooter

Warren Wilkinson

BRITISH SPRINT CHAMPION

Stephen Walton

SUPERMOTO CHAMPIONS

ACU/NoraSport British Supermoto Champions

Michelin Elite Open **Jamie Duncan**

Clubman Challenge **Luke Howson**

Novice Cup **Daryl Mead**

2 Stroke **Tom Laycock**

Over 45 **Andy Mitchell**

Lites **Casey Jones**

ACU BRITISH DRAG RACE CHAMPIONS

Top Fuel Champion

Steve Woollatt

Super Streetbike Champion

Steve Venables

Competition Bike

Champion **Louis Davies**

Funnybike Champion

Kars van den Belt

Junior Drag Bike

Liam Holgate

GRASS TRACK CHAMPIONS

ACU British 250cc Champion

Henry Atkins

ACU British 350cc Champion

Rob Finlow

ACU British 500cc Sidecar Champions

Shaun Harvey, Danny Hogg

ACU British 1000cc Left Hand Sidecar
Champions

Rob Heath, Kyle Fish

ACU British Masters Open 500cc Champion

James Shanes

ACU British 1000cc Sidecar Masters Open
Champion

Gareth Winterburn, Liam Brown

ACU 500cc Solo British Clubmans

Champion

Charley Powell

ACU 1000cc Sidecar British Clubmans
Champion

Kieran Hicks, Kieron Ivy

ACU British Under 21 Grass Track

Champion

Zach Wajtknecht

ACU British Sidecar Speedway Champions

Mark Cossar, Gareth Williams

Brian Stibbs Trophy

Mark Cossar

Jim Rendall Trophy

Paul Hurry

British Pre 75 Champions

250cc **Phil Ranson**

350cc **Neil Copestake**

500cc **Tim Curnock**

British Upright Champions

250cc **Chris Mackett**

350cc **Luke Harris**

500cc **Bob Dolman**

British Youth Grass Track Championship

Auto Cadet **Archie Rolph**

Cadet **Cooper Rushen**

Junior **Max Perry**

Intermediate **Cameron Taylor**

SpEEDWAY CHAMPIONS

British Youth 125cc Speedway Champion

Luke Harrison

British Youth 250cc Speedway Champion

Sam Hagon

British Under 16 Speedway Champion 500cc

Jordan Palin

British Under 19 Speedway Champion

Drew Kemp

British Under 21 Speedway Champion

Robert Lambert

Speedway Champion of Great Britain

Charles Wright

section

NATIONAL SpORTING
CODE

National Sporting Code of the ACU

FOURTH EDITION – REVISION 11: JANUARY 2020

CHAPTER 1 JURISDICTION

1.01	The Auto-Cycle Union	429
1.02	Application of the Code	429
1.03	Appendices to the Code	429
1.04	Alterations and Amendments	429
1.05	Interpretation of the Code	429
1.06	Loyal Observation of the Code	429

CHAPTER 2 NOMENCLATURE AND DEFINITIONS

2.01	Definitions	430
2.02	ACU	430
2.03	ACU Court	430
2.04	Affiliated Club	430
2.05	Membership of the ACU	430
2.06	AMRCO	431
2.07	BSPA	431
2.08	Certified Test	431
2.09	Competition	431
2.10	Social Gathering (Rally)	432
2.11	International Bodies	432
2.12	Local Centre	432
2.13	MCRCB	433
2.14	Meeting/Event	433
2.15	MSA	433
2.16	Non-Territorial Club	433
2.17	Parc Fermé	433
2.18	Permit	433
2.19	Practice	433
2.20	Practice Meeting/Test Day	433
2.21	Promotional Activity	433
2.22	RAC	433
2.23	Recognised Association	433
2.24	Recognised Promoter	434
2.25	Road	434
2.26	SACU	434
2.27	SCB	434
2.28	Venue	434

CHAPTER 3 ORGANISATION OF COMPETITIONS

3.01	Recognition of Authority	434
3.02	Standing Regulations	434
3.03	Supplementary Regulations	434
3.04	Announcement on Official Documents	435
3.05	Organisation of Competitions	435
3.06	Unauthorised Competitions	435
3.07	Competitions between Automobiles and Motorcycles	435

3.08	Permits for Competitions	435
3.09	Status of Competitions	436
3.10	Youth/Adult Competitions	438
3.11	Title of a Competition	438
3.12	Prohibition of Betting	438
3.13	Fixture List	438
3.14	Protection of Date	439
3.15	Television, Video Recording and Film Rights	439
3.16	Small unmanned aircraft (Drones)	439
3.17	Postponement, Cancellation or Abandonment of a Competition	439
3.18	Over-Riding Authority of The Auto-Cycle Union	439
3.19	Insurance	440
3.20	Official Programme	440
3.21	Assumed Name in Programme	440
3.22	Announcement of Results	440
3.23	False Advertisements	440
3.24	Permanent Course Licence/Temporary Course Certificate	441
3.25	Minimum Practice Period	441
3.26	Safety Plan/Risk Assessments	441

CHApTER 4 PERMITS AND ENTRIES

4.01	Permits	441
4.02	Permission of Local Centre	441
4.03	Application for Permit	441
4.04	Withdrawal or Refusal of Permit	441
4.05	Entries	442
4.06	Entries for International Competitions – Abroad	442
4.07	Time Limit for Entries	442
4.08	Unauthorised Entries	442
4.09	Entry Containing a False Statement	442
4.10	Refusal of Entries	442

CHApTER 5 OFFICIALS CONTROL AND DIRECTION OF COMPETITIONS

5.01	Judicial Officials	442
5.02	Executive and Administrative Officials	443
5.03	Assistants to Executive and Administrative Officials	444
5.04	Requirement to Sign-On	444
5.05	Age Limits for Officials and Assistants	444
5.06	Plural Appointments	444
5.07	Incompatibilities	445

CHApTER 6 TERMS OF REFERENCE AND DUTIES OF OFFICIALS

6.01	Stewards of the Meeting/Referee	445
6.01.1	Quorum for Meeting of Stewards	445
6.01.2	Stewards Reports	445
6.02	Race Director	445
6.03	Duties of the Race Director	446
6.04	Race Direction	447
6.05	Clerk of the Course	447

6.06	Duties of the Clerk of the Course	447
6.07	Powers of the Race Director	448

6.08	Powers of Race Direction	449
6.09	Powers of the Clerk of the Course	449
6.10	Event Director	449
6.11	Duties of an Event Director	449
6.12	Event Safety Officer	450
6.13	Duties of an Event Safety Officer	450
6.14	Secretary of the Meeting	450
6.15	Timekeeper	450
6.16	Chief Medical Officer	451
6.17	Technical Official	451
6.18	Duties of Starter and Line Judges	451
6.19	Incident Officer	451
6.20	Sound Inspector	451
6.21	Trial Observer	451
6.22	Measurer	452
6.23	Child Protection	452
6.24	Officials Riding Motorcycles at ACU Permitted Events	452

CHAPTER 7 ENTRANTS, RIDERS AND PASSENGERS

7.01	Entrant	452
7.02	Rider	452
7.03	Passenger	452
7.04	Age of Rider and Passenger	453
7.05	Licensing of Riders and Passengers	453
7.06	Entrant's Licence	453
7.07	Rider's Licence	453
7.08	Passenger's Licence	453
7.09	One Event Licence	453
7.10	Licences – Status and Validity	453
7.11	Refusal or Withdrawal of Licence	453
7.12	Production of Competition Licence or Trials Registration	453
7.13	Technical Inspection	454
7.14	Signing On/Signing Off	454
7.15	Mutual Responsibility of Entrant, Rider, Parent/Legal Guardian	454
7.16	Assumed Name	454
7.17	Change of Rider, Passenger or Motorcycle	454
7.18	Conduct of Riders	455
7.19	Irregular Entries	455
7.20	Absentees	455
7.21	Withdrawal of Entry	455
7.22	Finish of a Meeting and Prize Giving	455

CHAPTER 8 COURSES AND PUBLIC SAFETY

8.01	Courses	455
8.02	Permission to Use Land	455
8.03	Measurement of Distance on the Course	455
8.04	Licensing of Courses for Speed Events	455
8.05	Application for Permanent Course Licence	456
8.06	Validity of Permanent Course Licence or Temporary Course Certificate	456
8.07	Display of Permanent Course Licence	456
8.08	Application for Temporary Course Certificate	456

8.09	Availability of Temporary Course Certificate	456
8.10	Responsibility of Licence/Certificate Holder and Organiser	456
8.11	Alteration to Conditions	457
8.12	Course Inspection	457
8.13	Re-Inspection and Amendment of Licence or Certificate	457

CHAPTER 9 ANTI-DOPING, ALCOHOL AND MEDICAL

9.01	Anti-Doping	457
9.02	Prohibited Substances and Methods	457
9.03	Rules for the Enforcement of Anti-Doping	457
9.04	Testing Procedure	457
9.05	Costs for Anti-Doping Tests	458
9.06	Sanctions	458
9.07	Penalties	458
9.08	Alcohol	458
9.09	Medical Examination/Testing	458

CHAPTER 10 DISCIPLINARY AND ARBITRATION CODE

10.01	Principles	458
10.02	Penalties	459
10.02.1	Definition and application of Penalties	459
10.02.2	Specific Penalties	459
10.02.3	Plurality of Penalties	459
10.03	The ACU Disciplinary and Arbitration Bodies	460
10.03.1	The Judicial Panel	460
10.03.2	The ACU Sport Committees	460
10.03.3	The Clerk of the Course	461
10.03.4	The Steward(s) of the Meeting	461
10.03.5	The Panel of Adjudicators (POA)	462
10.03.6	The Judicial Enquiry	462
10.03.7	The ACU as a Party in the Judicial Proceedings	462
10.03.8	ACU Courts of Enquiry (COE)	463
10.03.9	The ACU Final Tribunal of Appeal (FTA)	463
10.04	Protests and Appeals	463
10.04.1	Right of Protest	463
10.04.2	Withholding of Prizes and Awards in case of Protest or Appeal	464
10.04.3	Procedure and time limit for Protests	464
10.04.4	Protest Fees	464
10.04.5	Hearing a Protest	464
10.04.6	Effect of the decision of the Clerk of the Course	464
10.04.7	Right of Appeal	464
10.04.8	Procedure and Time limits for the lodging of Appeals	464
10.04.9	Lodging of an Appeal to a Local Centre Court	465
10.04.10	Lodging of an Appeal to the COE/FTA/POA	465
10.04.11	Appeal Fees	465
10.04.12	Fees Payable upon an Adjournment	466
10.04.13	Fees Payable upon Withdrawal of an Appeal	466

10.04.14	Time Limits for the Hearing of Appeals	466	Ti
10.04.15	Effect of an Appeal	466	Ef
10.05	Procedure Before all the Disciplinary and Arbitration Bodies	466	
10.05.1	Right to a Hearing	466	

10.05.	The Hearing	467
2		
10.05.	Witnesses and Experts	467
3		
10.05.	Judgement	467
4		
10.05.	Notification of Judgements	467
5		
10.05.	Publication of Judgements	467
6		
10.06	Costs of Procedure	467
10.06.	Payment of Fines and Costs	468
1		
10.07	Reciprocity of Penalties	468
10.08	Law of Mercy	468
10.09	Arbitration Clause	468

CHAPTER 11 OFFENCES AND PENALTIES

11.01	Breach of Rules	468
11.02	Re-Run	469
11.03	Allocation of Proceeds from Fines etc.	469
11.04	Quashing a Competition	469
11.05	Notices	469

APPENDIX A DISCIPLINARY DECISIONS & PROTEST & APPEAL PROCEDURE

470

APPENDIX B PROTEST AND APPEAL PROCEDURE – TRIALS AND ENDURO

471

APPENDIX C INSURANCE

1.	General	472
2.	Legal Liability	472

APPENDIX D MOTORCYCLES AND ACCESSORIES

1.	Motorcycles	473
2.	Quad Machines	473
2.	Freedom of Construction	473
3.	Categories and Groups of Motorcycles	473
4.	Classes	474
5.	Measurement of Engines	475
6.	Carburettors or other Air Input Control Instruments	475
7.	Identification Numbers	476
8.	Examination of Machines	476
9.	Measurement of Machines	476
10.	Advertising	476
11.	Brakes	477
12.	Dangerous Construction	477
13.	Positions of Rider and Passenger	477
14.	Throttle (Accelerator) Controls	477
15.	Chain Guards	477
16.	Exhaust Sound Control	477
17.	General	478

FOURTH EDITION – REVISION 11: JANUARY 2020

CHApTER I JURISDICTION

1.01 The Auto-Cycle Union

1. The Auto-Cycle Union Limited (ACU) is the Internationally Recognised Governing Body for the Sport of Motorcycling throughout the British Isles, excluding Ireland, for machines as defined in the Appendices to this Code.
2. In order that the control of motorcycle sport shall be exercised in a fair and equitable manner, the ACU National Council has approved these rules designated, “The National Sporting Code”, hereinafter also called “the Code” or “NSC” which are generally in conformity with the International Sporting Code of the Fédération Internationale de Motocyclisme.

1.02 Application of the Code

1. This Code supersedes the previous Third Edition of the National Sporting Code and governs the relations arising in any matter whatsoever in connection with the Sport of Motorcycling and Social Gatherings as between the ACU and/or amongst Officials, Organisers, Entrants, Riders and Passengers, Affiliated Clubs and Club Members.
2. This Code shall have no authority over competitions, officials, championships and events under the control of the MCRCB or SCB, other than in the case of the SCB for judicial functions as described in Chapter 10 and 11 of this Code.
3. Such competitions, officials, championships and events shall be organised in accordance with their respective sporting codes.

1.03 Appendices to the Code

1. Appendices to the Code include Insurance Regulations, Standing Regulations for each discipline as published in the current ‘ACU Handbook’ and Supplementary Regulations defining the nature of and governing technical requirements. Rules for the conduct and control of Competitions for the various disciplines of the sport of motorcycling as established, shall form part of this Code and have the same force in their application. In the event of any conflict between the National Sporting Code and its Appendices, the National Sporting Code shall prevail.

1.04 Alterations and Amendments

1. This Code and its Appendices may be altered from time to time. No revised rule shall be effective unless it has been approved by the National Council of the ACU and has been published.

1.05 Interpretation of the Code

1. In cases of dispute, the National Council of the ACU is empowered to decide the interpretation of this Code. Where any word used within this Code shall refer to gender, that word shall be deemed to relate to either sex.

1.06 Loyal Observation of the Code

1. No Member of the ACU or any Affiliated Club or other approved body which has formally undertaken to observe and comply with this Code and no person licensed or otherwise authorised to enter or participate in or officiate at any Competition governed by this Code shall:
 1. Assist any person or body that does not comply with and/or conform to this Code or the Rules or Code of the SCB, the MCRCB, or acts in any manner contrary thereto.
 2. Belong to, or lend his name to, or be an Officer of, any such body.
2. Dispensation from this rule may be given where a body can satisfy the ACU that its rules and

regulations are compatible with those of the ACU and that competitors, officials and spectators receive similar protection (i.e. insurance and safety) to that applicable to ACU permitted events and on condition that any other criteria laid down in Government legislation such as official notification or approval of the running of event(s) are met (see 3.06, final paragraph).

CHAPTER 2 NOMENCLATURE AND DEFINITIONS

2.01 1. In addition to the definitions, and abbreviations of terms appearing in this Code or its appendices, the following phraseology and abbreviations shall be adopted and their definitions shall be applicable to all Supplementary Regulations and for general use.

2.02 ACU

1. The Auto-Cycle Union Limited, (ACU – British Motorcycle Sport), founded in 1903 as a branch of the Royal Automobile Club (RAC) and made independent of the RAC in 1999, consisting of Affiliated National Clubs, Affiliated Non-Territorial Clubs, and Affiliated Local Motorcycle Clubs forming Local Centres and other recognised Associations. The constitution of the ACU is laid down in 'The Rules of the Union'.
2. Where ACU is used to indicate the governing authority, it is that authority vested in the National Council of the Auto-Cycle Union for the governance of the sport of motorcycling.

2.03 ACU Court

1. An ACU Court shall be a body set up for Jurisdiction or Arbitration purposes as follows.
1. **Clerk of the Course:** To adjudicate all protests arising out of a meeting.
2. **Steward(s) of the meeting:** To adjudicate all Appeals arising out of a meeting.
3. **Referee:** To adjudicate all Appeals arising out of a meeting.
4. **ACU Centre Court:** To adjudicate on any matter referred to them by the Stewards of the meeting with respect to an event for which they have issued the Permit. To adjudicate on any matter of conflict or complaint from a Club or Member of a Club under the jurisdiction of that Centre.
5. **ACU National Court:** To adjudicate on any matter referred to them by the Stewards of the meeting with respect to an event for which the ACU Headquarters have issued the Permit. To adjudicate on any matter of conflict or complaint from a Centre, Non-Territorial Club or National Official.

2.04 Affiliated Club

1. Any Affiliated Local Motorcycle Club or Non-Territorial Motorcycle Club, Association, Institution or other body or section of such body connected with the sport or recreation of motorcycling which is affiliated to the ACU in accordance with the Rules of the Union in force at any one time, and consisting of members, whether paid up individuals or Honorary Members, who are entered on the Club roll and are eligible to become Members of the ACU.

2.05 Membership of the ACU

1. Membership of the ACU is defined as follows:
 1. **Affiliated Member:** An individual who is a fully paid up member of one or more Clubs affiliated to the ACU. Such an individual shall be eligible to take part as an Official of the ACU or Competitor in any competition organised under this National Sporting Code provided he holds a current Competition Licence/Trials Registration, and meets any other eligibility requirement specified in the National Sporting Code, its Appendices or Event Regulations. All Applications for Competition Membership are subject to the approval of the Board of Directors of ACU. (See also Rules of the Union Article (B) (19))

2 Associate Member: An individual who is an Associate Member is not required to be a fully paid up member of any Club affiliated to the ACU. Such an individual shall be eligible to receive an ACU Handbook and to a variety of member benefits that may be made available from time to time. Associate Members are not eligible to participate as a competitor in any competition organised under this National Sporting Code unless also a Competition Member or authorised in the Supplementary Regulations of a particular competition. (e.g. National Rally). The holder of an Associate Membership having paid the annual individual registration fee direct to the ACU in accordance with the Rules of the Union in force at any one time. All Applications for Associate Membership are subject to the approval of the Board of Directors of the ACU. (See also Rules of the Union Article (B) (19))

2.06 AMRCO

1. The Association of Motor Racing Circuit Owners.

2.07 BSpA

1. British Speedway Promoters' Association.

2.08 Certified Test

1. A test of which the purpose is to obtain information as to the characteristics of a motorcycle or accessory or material used in connection with a motorcycle, and which is conducted in accordance with certain specified conditions.

2.09 Competition

1. Any part of meeting/event, in which one or more riders compete against each other, or against time, or attempt to fulfil certain pre-determined conditions.
2. A competitive element introduced into a Social Gathering whereby one rider competes against another shall itself constitute a competition.
3. Competitions are of either a speed or non-speed type.

SPEED EVENTS

1. **Beachcross:** A race on or adjacent to the sea shore with some of the characteristics of motocross.
2. **Drag Race:** A race between two competitors over a flat straight course of a quarter of a mile in length.
3. **Grass Track Race:** A race on a predetermined continuous, originally grassed and generally flat surface.
4. **Hillclimb:** A race from point to point usually on a metalled and sealed surface with bends and a continuous severe gradient. Each competitor will ride individually.
5. **Motocross:** A cross country race on a closed predetermined continuous course presenting severe irregularities of surface and gradient.
6. **Pocket Bike:** A race for miniature motorcycles and miniature motorcycle sidecars with rigid frames and propelled by a petrol engine. The course will be on a metalled sealed surface and be predetermined.
7. **Road Race:** A race on a metalled and sealed surface making a continuous predetermined course which has the general characteristics of an ordinary highway.
Also Circuit Road Race: A race on a permanent circuit the surface of which is metalled and sealed with either banked or unbanked bends and corners.
8. **Sand Race:** A race on the seashore on a predetermined continuous, generally flat sand course.
9. **Scooter Racing:** Road racing for both solo and combination scooters. Machines are from 50cc to 650cc, based either on classic geared scooters or modern automatics.

10. **Speed Record attempt:** A record is the best result obtained over a certain distance or within an imposed time limit.
11. **Speedway:** A race, or venue for a race conforming to the requirements of and licensed by the Speedway Control Bureau. No venue other than one licensed by the Speedway Control Bureau shall be described as a Speedway and no motorcycle event shall be described as Speedway unless it is held under a permit authorised by the Speedway Control Bureau.
12. **Sprint:** A race from point to point on a metalled and sealed surface, approximately level and not exceeding one mile in length, between two or more competitors or individually against time.
13. **Supercross/Arenacross:** A race, held in a stadium type facility, on a closed predetermined continuous course containing severe irregularities of surface and gradient.
14. **Supermoto:** A race on a predetermined flat or undulating course which is a mixture of natural and metalled sealed surfaces.
15. **Twisty Sprint:** A race from point to point on a metalled and sealed surface, approximately level using left and right turns and not exceeding one mile in length, between two or more competitors or individually against time.

NON SPEED EVENTS

1. **Enduro:** A long distance event of endurance and reliability with the course predominantly of an off-road cross country nature.
2. **Hare and Hounds:** A group start event of no less than 2 hour duration held over undulating ground where the target will be to achieve a set number of laps within the time allowed.
3. **Trial:** A test of riding skill and balance over a variety of observed obstacles with riders incurring penalties for 'footing' or stopping or for failing to fulfil other conditions as may be stated in the supplementary regulations.
4. **A Gymkhana:** An event held wholly on private ground and in which no test is determined solely by the speed of the competing motorcycle, or by the skill of the rider in controlling the machine, and in which if there are timed tests there will be at least an equal number of untimed tests. No test may be timed to an accuracy of less than 5 seconds.

2.10 Social Gathering (Rally)

1. A Social Gathering is an event where the participants do not compete against each other but may be required to satisfy general criteria to achieve an award. A Social Gathering may include a competition as defined under 2.08.
A Social Gathering may be:
 1. A Navigational Scatter Road Rally or Road Safety Rally taking place over various routes converging on a rallying point fixed in advance in which average speed is limited, or
 2. An activity organised with the prime objective of assembling touring motorcyclists at a point fixed in advance.

2.11 International Bodies

1. **FIM:** The Fédération Internationale de Motocyclisme, the International Controlling Body for Motorcycle Sport.
2. **FIME:** The Fédération Internationale de Motocyclisme Europe, the Body established by the FIM to control Continental Motorcycle Sport within the continent of Europe.
3. **FMN:** Fédération Motocycliste Nationale, a National Controlling Body of Motorcycle Sport recognised as such by the FIM.
4. **FMNR:** The FMN under whose jurisdiction an International event is held.

2.12 Local Centre

1. A grouping of ACU affiliated Local Motorcycle Clubs, having their headquarters within a

district or area designated by the ACU, which the ACU shall recognise as being the body of the ACU responsible for the local encouragement of the sport of motorcycling under this Code.

2.13 MCRCB

1. The Motorcycle Circuit Racing Control Board. The body to which the control of National level motorcycle Road Racing on permanent road race circuits belonging to and under the control of AMRCO has been delegated by the ACU.

2.14 Meeting/Event

1. An assembly of riders, passengers if appropriate, and officials under official control at which one or more competitions are held, or performance registered.

2.15 MSA

1. The Royal Automobile Club Motor Sports Association Ltd.

2.16 Non-Territorial Club

1. A Club, Association or other body or section of such body, connected with the sport and recreation of motorcycling, having objectives, activities and membership which does not restrict it to Local Centre membership and having a minimum membership as shall be determined by the ACU, and which is affiliated to the ACU, in accordance with the Rules of the Union. Where a Non-Territorial club has local sections, these sections shall affiliate to the Local Centre and will conduct their sport through the normal Centre procedures.

2.17 parc Fermé

1. An area in which no repairs or servicing is permitted, except as allowed by the Supplementary Regulations.

2.18 permit

1. An authorising document issued in accordance with Article 3.08.

2.19 practice

1. That part of an event intended to allow a rider to become familiar with the course. In certain events, performance during specified periods of practice may be used by the organisers to determine starting order or position.

2.20 practice Meeting/Test Day

1. A practice meeting/test day is a meeting which is instigated, announced and conducted by an Affiliated club and in which there is no element of competition. See also Article 3.08 (h).

2.21 promotional Activity

1. A Non-competitive activity designed solely to enable participants to experience riding motorcycles.
2. To participate in this type of activity the rider does not require to be a member of an ACU Club or to have any competition licence.

2.22 RAC

1. The Royal Automobile Club.

2.23 Recognised Association

1. Any organisation or body (not being an affiliated club) which shall be recognised by National

Council, having an interest in the sport of motorcycling which is not considered to be in conflict with the interests of the Auto-Cycle Union. Recognised Associations shall be entitled to:

1. Receive all annual and periodical publications.
2. Attend and speak at meetings of the Non-Territorial Board.
3. Attend seminars and other meetings by invitation, for which a fee may be charged.

2.24 Recognised promoter

1. A Company or other body connected with the sport or recreation of motorcycling which is affiliated to the ACU in accordance with the Rules of the Union in force at any one time.
A Recognised Promoter shall be entitled to:
 1. Receive all annual and periodical publications.
 2. Attend and speak at meetings of the Non-Territorial Board.
 3. Attend seminars and other meetings by invitation, for which a fee may be charged.

2.25 Road

1. A route having the general characteristics of a public highway.

2.26 SACU

1. Scottish Auto-Cycle Union.

2.27 SCB

1. The Speedway Control Bureau. The body to which the control and governance of National level motorcycle Speedway Racing on permanent Speedway Circuits belonging to and under the control of BSPA has been delegated by the ACU.

2.28 Venue

1. That geographical location where the competition takes place and upon which all ancillary activities directly connected with the competition take place but excluding any and all activities beyond the boundary of the area of land over which the organisers have control.

CHAPTER 3 ORGANISATION OF COMPETITIONS

3.01 Recognition of Authority

1. Every ACU competition shall be held under this Code. Every person, organising, officiating at, entering or participating in such a competition shall be an affiliated member of the ACU, with the exceptions as in articles 3.08 and 5.02 and shall be deemed to be acquainted with, and shall be bound by this Code with its Appendices and the Supplementary Regulations that may be applicable and to have renounced the right to have recourse to any court or tribunal otherwise than as provided for in this Code or the code of the FIM if applicable (see NSC 5.02).

3.02 Standing Regulations

1. The Standing Regulations, additional to, but not contradictory to this Code shall be those as drawn up by the appropriate sport committee and shall govern the specific needs of each discipline of the Sport.

3.03 Supplementary Regulations

1. For every competition there shall be drawn up Regulations, supplementary to this Code and its Appendices. These Supplementary Regulations shall not be in conflict with this Code or its Appendices and shall be approved by the authority issuing the permit for the competition (see NSC 1.03).
2. The Supplementary Regulations are to include all information relevant to the particular

competition for the information of Entrants, Riders and Passengers, and shall include a form inviting entry into the competition.

3. The Supplementary Regulations together with the Entry Form and all other official documentation shall carry the Permit Number.
4. Once approved by the Permit Issuing Authority, Supplementary Regulations cannot be amended without the further approval of the Permit Issuing Authority except as described in 3.03.5. If any change is approved, all entered competitors must be informed in writing.
5. The Stewards of a meeting may for urgent reasons of safety or necessity authorise a change to the Supplementary Regulations. Any change decided must be transmitted to all entrants and riders and shall not be subject to appeal.

3.04 Announcement on Official Documents

1. All Supplementary Regulations, Entry Forms, Official Programmes and other official communications, shall include the status of the competition, (National, Open or Restricted etc.) and shall be conspicuously marked with the words "Held under the Sporting Code of the ACU", and where applicable "the FIM" or "the FIME".

3.05 Organisation of Competitions

1. No competition shall be held, other than by the ACU Headquarters itself, without an organising permit having been granted. Any of the following may act as Organisers, and hold a competition as defined in this Code subject to the necessary approvals as defined in this Code being obtained.
 1. The ACU Headquarters
 2. A Local Centre of the ACU
 3. A Non-Territorial Club
 4. An Affiliated Local Motorcycle Club or combination of Clubs
 5. A Recognised Promoter
 6. Any other person or body approved by the National Council of the ACU in exceptional circumstances for the organisation of a specific meeting/event.

3.06 Unauthorised Competitions

1. The organisation or running of any meeting or series of meetings not conforming to the NSC, its Appendices or the Regulations, for which an ACU Permit has not been issued is not recognised by the ACU.

3.07 Competitions between Automobiles and Motorcycles

1. It is prohibited for automobiles as defined by the MSA and motorcycles as defined in this Code to compete against each other in the same race.
2. A meeting may include separate events for automobiles and motorcycles, as defined in this Code, provided it is authorised by the ACU Committee responsible for the discipline concerned and consent of the MSA has been granted.

3.08 permits for Competitions

1. Permits for all Road Race, Drag, Sprint, Supermoto, Supercross and Arenacross competitions, are issued by ACU Headquarters.
2. Competitions on AMRCO Circuits.
In accordance with agreements currently in force, members of AMRCO shall be entitled to appoint an ACU Affiliated Club to hold events of lower than National status on circuits belonging to or under the control of members of AMRCO. Such events shall be run in accordance with the ACU Rules and Regulations in force at the time save that any Permit for such events must be approved in advance by the MCRCB.

3. Where A Local Centre or Region is the Permit Issuing Authority, all Permit Applications are to be forwarded to the Competition Secretary or Permit Officer of the Centre or Region for information and issue of the Permit.
4. Permit applications for AMRCO/MCRCB events and all other Permits issued by ACU HQ will be individually notified to the ACU Local Centre for information.
5. Except for Road Racing, Drag, Sprint and Supermoto meetings held on courses that are subject to Permanent Course licences and other events on land with planning permission, events which are to take place either wholly or partially within the boundaries of a Centre other than that of the Permit Issuing Authority must be notified to the Centre in which the event is to be held by the Permit Issuing Authority prior to the issue of the permit.
6. Before issuing the Permit, the Permit Issuing Authority is required to take into account any observations, recommendations or objections made by the Centre in which the event is to take place providing these are received within the 10 days following the date the original notification was made.
7. Approval of the Local Centre in whose territory an event is proposed to be held must be obtained by any organising club affiliated to that Centre (except for Road Racing, Drag, Sprint and Supermoto meetings held on courses that are subject to Permanent Course licences and other events on land with planning permission). Such permission shall not be unreasonably withheld.
8. Any otherwise irresolvable disputes between event organizers or between a Permit Issuing Authority and an organizer or organizers shall be referred to ACU Headquarters for mediation. The ACU will be the final arbiter in these matters from which there will be no appeal.
9. Permits for Practice.
 1. **For Trials.** The requirement for a Trial practice is there needs to be a licenced Clerk of the Course appointed. There is to be no element of competition, no results issued or published and no Observers put in place. A Trials Registered rider can pay the entry fee required and participate in the practice event. Non-ACU Trials Riders will need to pay an additional fee set by ACU Head Office. There will need to be two signing on forms. One form for ACU Trials Registered Riders who are required to pay the appropriate entry fee and one form for Non-ACU Trials Riders. For Non-ACU Trials Riders, they will be required to pay the entry fee as appropriate plus an additional to the Organisers. The fee to be determined by ACU Head Office.
 2. **For Enduro/Motocross.** The requirement for an Enduro/Motocross practice is that there needs to be a licenced Clerk of the Course appointed for the practice. There will be no element of competition, no mass starts and no results issued or published. An ACU licenced holder can pay the entry fee required and participate in the practice event. Non-ACU Licenced Holders will need to pay an additional fee set by ACU Head Office. There will need to be two signing on forms. One form for ACU Licence Holders who are required to pay the appropriate entry fee and one form for Non-ACU licence holders who are required to pay the appropriate entry fee plus an additional to the Organisers. The fee to be determined by ACU HeadOffice.

3.09 Status of Competitions

1. **International**
 1. The Permit shall be issued by the ACU Headquarters for a meeting inscribed on the International Calendar of the FIM and having an FIM International Meeting Number (IMN).
 2. An International meeting is open to Entrants and Riders of more than one nation who must hold an International Licence or a National Licence issued by the ACU valid for the particular meeting concerned.
 3. All riders not holding a Licence issued by the ACU or SACU must carry proof of Insurance and a written Start Permission document issued by their FMN. NOTE: This includes all riders holding a licence issued by the MCUI.

2. European Open

1. The permit shall be issued by ACU Headquarters for a meeting inscribed on the Calendar of the Fédération Internationale de Motocyclisme Europe (FIME) and having a European Meeting Number (EMN).
2. A European Open meeting is open to Entrants and Riders of more than one European nation who must hold the appropriate Competition Licence valid for the particular meeting concerned.
3. All riders not holding a Licence issued by the ACU or SACU must carry proof of Insurance and a written Start Permission document issued by their FMN. NOTE: This includes all riders holding a licence issued by the MCUI.

3. National

1. The Permit shall be issued by the ACU Headquarters.
2. A National meeting is open to Entrants and Riders who are the holders of a National or International Licence or Trials Registration valid for the particular meeting concerned issued by any federation.
3. All riders not holding a Licence issued by the ACU or SACU must carry proof of Insurance and a written Start Permission document issued by their FMN. NOTE: This includes all riders holding a licence issued by the MCUI.

4. Open

A. Where the meeting is to be organised by a Centre or Centre Affiliated Club but is not a meeting as described in Article 3.08.1 above.

1. An Open permit is issued by the Local Centre to which the organising Club is affiliated.
2. An Open meeting is open to Entrants and Riders who hold a valid ACU or SACU Licence or Trials Registration for the meeting concerned.

B. Where the meeting is to be organised by a Non-Territorial Club or for any meeting described in 3.08.1 above.

1. An Open permit is issued by ACU Headquarters.
2. An Open meeting is open to Entrants and Riders who hold a valid ACU or SACU Licence or Trials Registration for the meeting concerned.

5. Restricted

A. Where the meeting is to be organised by a Centre or Centre Affiliated Club but is not a meeting described in Article 3.08.1 above.

1. A Restricted permit is issued by the Local Centre to which the organising Club is affiliated.
2. A Restricted meeting is open to Entrants and Riders who hold a current ACU or SACU Licence or Trials Registration valid for the meeting concerned.
3. The Supplementary Regulations issued for the event must specify all restrictions and requirements of eligibility.

B. Where the meeting is to be organised by a Non-Territorial Club or for any meeting as described in Article 3.08.1 above.

1. A Restricted Permit is issued by ACU Headquarters.
2. A Restricted meeting is open to Entrants and Riders who hold a current ACU Licence or Trials Registration valid for the meeting concerned.
3. The Supplementary Regulations issued for the event must specify all restrictions and requirements of eligibility.

6. Eligibility of Foreign Riders in Open and Restricted Meetings

1. The Supplementary Regulations issued for the event must specify the licence qualification and eligibility requirements of foreign riders.

2. All riders must have a current Licence and Start Permission from their own Federation valid for the event.
3. **Note:** In certain circumstances for events other than Road Racing, Sprint, Drag Racing and Track Racing it is possible for European Competitors to take part without producing a Start Permission or Insurance. Organisers should refer to the current ACU Handbook Insurance section for further information.
7. **Practice Meetings and Test Days**
 1. Permits for Practice Meetings and Test Days may be issued on application to ACU Headquarters.
 2. No such event may be held unless the appropriate Permit and Insurance has been issued.
8. **Social Gatherings**
 1. Permits for Social Gatherings may be issued on application to the Permit Issuing Authority (Local ACU Centre or ACU Headquarters).
 2. No such event may be held unless the appropriate Permit and Insurance has been issued.
9. **Training Days**
 1. The ACU Training Department will issue Permits for all functions involving the training of riders by approved coaching personnel or the training of officials by authorised trainers.
 2. No such event may be held unless the appropriate Permit and Insurance has been issued.
10. **Special Event Permits**
 1. A Permit issued by ACU Headquarters for any event, the Regulations for which have been approved by the appropriate Sport Committee or the Board of Directors of the ACU.
 2. Such events will be those deemed to be in the interest of the sport of motorcycling generally but may not fall within the categories mentioned above.
- 3.10 **Youth/Adult Competitions**
 1. A competition including separate classes for Youth as defined in the discipline Standing Regulations shall be organised under a Permit, authorised by the ACU Headquarters or Local Centre.
- 3.11 **Title of a Competition**
 1. Approval of the following titles shall be given on the recommendation of a Sport Committee of the ACU subject to the approval of the Board of Directors.
 1. **Grand Prix** The use of the words "Grand Prix" in the title of any competition held under the jurisdiction of this Code can be authorised only by the ACU and the FIM.
 2. **Classic** No competition or series of competitions shall include the word "Classic" in its title, or be advertised as a "Classic" unless it is so authorised by the ACU.
 3. **British** No competition or series of competitions shall include the use of the word "British" in its title unless agreed by the ACU.
 4. **Championships** No International or National competition or series of competitions shall be described as a "Championship" unless agreed by the ACU.
- 3.12 **prohibition of Betting**
 1. At meetings held under these rules Public Betting shall not be permitted.
- 3.13 **Fixture List**
 1. Annually, the FIM will publish the "Calendar of Events" for all International Meetings.

2. All International events to be held under the jurisdiction of the ACU shall be inscribed on the International Calendar only by the ACU Headquarters.
3. The ACU Headquarters will publish a Fixture List of National and certain other lower status events.
4. Once the National Calendar has been published, the published dates shall stand, except in the case of force majeure.

3.14 protection of Date

1. No event either competitive or for practice shall be held on the Sunday in November each year designated "Remembrance Sunday".

3.15 Television, Video Recording and Film Rights

1. No competition shall be televised or filmed for video recording for professional purposes unless the prior approval of the ACU Headquarters has been obtained. The only exception to this requirement is in respect of television news or feature programmes where the viewing time from any one competition is less than four minutes.
2. Subject to prior agreement with the owners of permanent circuits, the ACU Headquarters reserves the right to negotiate contracts for the television, video recording, transmission by cable or film rights for any competition or series of competitions held under jurisdiction of this Code.

3.16 Small unmanned aircraft (Drones)

1. Subject to the prior agreement with the Event Organiser, any person wishing to operate a Small Unmanned Aircraft (Drone) in the vicinity of an ACU permitted event must provide proof of adequate insurance and sign on at an event in the same manner as any other Media type person. Any small unmanned aircraft being operated at an ACU event must comply with the rules and regulations as provided by the UK Civil Aviation Authority (CAA) or other statutory regulatory body responsible for these matters.

3.17 postponement, Cancellation or Abandonment of a Competition

1. A meeting or competition forming part of a meeting shall not be postponed, cancelled or abandoned unless provision for doing so has been made in the Supplementary Regulations, save as provide for in this Article or in Article 6.01 (Stewards). In exceptional circumstances and for justifiable reasons the Organising Club or Body is permitted to postpone or cancel a meeting for which it holds a Permit. The Permit Issuing Authority and all the riders who have submitted an entry must be immediately informed about changes of dates or cancellations. A short term change of up to 48 hours necessitated by extraordinary circumstances is not to be considered as a change of date and the original Permit will remain valid. In any case of a change of date the entries submitted will be valid only if the riders confirm their acceptance of the new date of the meeting after having been given the opportunity of withdrawing their entries by an agreed date.

3.18 Over-Riding Authority of The Auto-Cycle Union

1. The ACU Headquarters shall have the right to declare any competition held within its jurisdiction the holding of which would, in the opinion of the ACU, be prejudicial to the interests of either the sport or the ACU, to be an unauthorised competition, and also to veto any decision of a Local Centre, Organiser or body of Organisers, Affiliated Club or Association of Affiliated Clubs, Steward or body of Stewards, which in the opinion of the ACU would be so prejudicial.

3.19 Insurance

1. All competitions held under the jurisdiction of the ACU shall be insured under policies put into effect by ACU Headquarters. In addition all riders competing in events held under an ACU permit shall be covered by ACU policies in respect of Personal Accident and Public/Promoters Liability subject to certain exceptions and shall pay the required insurance fee.
2. Riders are responsible for 'Road Traffic Acts insurance' when part or the entire course of an event traverses a public road.

3.20 Official programme

1. For all meetings where a charge is made for the admission of spectators the Organisers shall publish an Official Programme.
2. The Official Programme shall contain the following information:
 1. A statement that the competition is held under the Code of the ACU and the Code of the FIM or FIME if applicable.
 2. The Permit Number and, where applicable, the Course Licence or Certificate Number.
 3. The names of the principal Officials and an address and telephone number for correspondence with the Organisers.
 4. The time of start and the schedule of the competitions.
 5. The names of Entrants, Riders and Passengers with their machines and Riding Numbers.
 6. The appropriate Warning and Disclaimer Notices as specified under "Safety Precautions" in the current ACU Handbook.
 7. Any other notices as may be required from time to time by the ACU.
 8. An acknowledgement that the event is staged in accordance with the ACU/FIM Environmental Code.
3. For events of Open and Restricted status where an Official Programme is not required, a list of riders, riders club and their machines is a minimum requirement.
4. A copy of the Programme or List of Entries is to be sent to the Permit Issuing Authority at the conclusion of the meeting.

3.21 Assumed Name in programme

1. Any assumed name, if duly registered, shall be indicated on the Official Programme between inverted commas (see NSC 7.16).

3.22 Announcement of Results

1. The announcement of results must be made as per the Standing Regulations or Supplementary Regulations for each of the disciplines and if not issued or posted on the day, shall be sent or made available to the competitors as soon as practicable, but in no case later than 14 days after the competition has concluded.

3.23 False Advertisements

1. Any Entrant or corporate body advertising the results of an ACU authorised competition, record attempt or official certified test, shall state the exact conditions of the performance referred to, the nature of the competition, the category and class of the motorcycle and, where applicable, the make of the engine if not the maker's own construction, and the position obtained in its category and class.
2. Any infringement of this rule, whether by way of omission from or addition to the particulars required to be stated or otherwise, shall render the person or body by whose authority or on whose behalf the advertisement is published or issued liable to the penalties provided in Chapter 10. This rule shall also apply to any advertisement in connection with any tour or test not officially observed.

3.24 permanent Course Licence/Temporary Course Certificate

1. All courses for Speed Events staged in accordance with this Code, whether permanent or temporary, must be licensed or certified by the ACU (see Chapter 8).

3.25 Minimum practice period

1. For any race there must be a minimum period for practice on the actual course, the details of which must be stated in the Supplementary Regulations.

3.26 Safety plan/Risk Assessments

1. The Organiser of an ACU Event held on an International/European permit shall prepare a Safety Plan in addition to the Risk Assessment unless the relevant ACU Sport Committee specifies otherwise. The Safety Plan is to be confirmed as completed to the Permit Issuing Authority once month prior to the start of the event.

CHAPTER 4 PERMITS AND ENTRIES

4.01 permits

1. The ACU retains the right to require all Permits of a certain discipline of whatever status, to be issued only by the ACU Headquarters. The ACU Headquarters shall approve the date, venue and Supplementary Regulations before issuing a permit.

4.02 permission of Local Centre

1. Except for Road Racing, Drag, Sprint and Supermoto meetings held on courses that are subject to Permanent Course licences and other events on land with planning permission, events which are to take place either wholly or partially within the boundaries of a Centre other than that of the Permit Issuing Authority must be notified to the Centre in which the event is to be held by the Permit Issuing Authority prior to the issue of the permit.
2. When issuing the Permit, the Permit Issuing Authority is required to take into account any observations, recommendations or objections made by the Centre in which the event is to take place providing these are received within 10 days following the date that the original notification was made.
3. Notification to the Local Centre in whose territory an event is proposed to be held must be made by any Organising Club affiliated to that Centre or any other Organising Club affiliated to the ACU (except for Road Racing, Drag, Sprint and Supermoto meetings held on courses that are subject to Permanent Course licences and other events on land with planning permission). Such notification shall not be unnecessarily delayed.
4. Any otherwise irresolvable disputes between event organisers or between a Permit Issuing Authority and an organiser or organisers shall be referred to ACU Headquarters for mediation. The ACU will be the final arbiter in these matters from which there will be no appeal.

4.03 Application for permit

1. Applications for the reservation of a date as well as the issuing of a Permit, as specified in Art. 3.08, shall be lodged within the time period laid down by the Permit Issuing Authority.
2. The Permit Issuing Authority shall decide fees, together with the method and timing of payment.

4.04 Withdrawal or Refusal of permit

1. The Board of Directors, a Sport Committee or a Local Centre of the ACU may decline to grant or may withdraw a permit. A reason must be stated. An appeal against such a refusal or withdrawal may be made to the Judicial Panel through the General Secretary.

4.05 Entries

1. Entries for all competitions shall be made on the form provided by the Organiser, based on the model specified by the ACU, and accompanied by a completed Parental Agreement form in respect of any Rider or Passenger under the age of 18 years.
2. The entry form shall provide, where appropriate, for the inclusion of the names and addresses of the Entrant, the Rider and Passenger, their Competition Licence or Individual Affiliate Member number, the registration number, make and engine capacity of machine entered, their Club and a contact telephone number for the Entrant/Rider.
3. Each entry must be signed by the Entrant, Rider and Passenger accepting the Conditions and Regulations for the competition and agreeing to be bound by them.
4. Any entry not accompanied by the required fee shall be null and void.
5. All entry forms shall be available at the start of all competitions.

4.06 Entries for International Competitions – Abroad

1. Entries for International competitions or European Community competitions to be held outside the territorial jurisdiction of the ACU must be endorsed by the ACU Headquarters as confirmation of all necessary insurance requirements having been met.

4.07 Time Limit for Entries

1. Entries for competitions shall close as announced in the Supplementary Regulations.

4.08 Unauthorised Entries

1. An Organiser shall not publish as entered, the name of any Entrant, Rider or passenger in respect of whom a duly completed entry form has not been received.

4.09 Entry Containing a False Statement

1. An entry which contains a false declaration shall be considered null and void. The Entrant and/ or Rider may be deemed to be guilty of a breach of these rules, and the entry fee may be forfeit.

4.10 Refusal of Entries

1. Organisers of competitions may select entries as they wish and (whether or not the number of entries submitted exceeds the maximum number to be accepted in the competition) may refuse any entry provided that:
 1. Notification of refusal is given in writing so as to reach the Entrant as soon as possible, and in the case of a National Competition, at the latest within 48 hours after the published date of closing of entries.
 2. No entry shall be refused on the grounds of age, gender, disability, ethnic origin, creed, colour, social status, sexual orientation, occupation, religion or political opinion.
 3. If requested to do so an organiser must inform the Competitor or Entrant of the reason for refusal or acceptance of an entry.
2. In the case of any event in a Series of events the result of which constitutes a Championship, an entry may be refused only with the permission from the body organising the Championship series.

CHAPTER 5 OFFICIALS CONTROL AND DIRECTION OF COMPETITIONS

1. **All competitions held under the jurisdiction of this Code shall be the responsibility of certain Officials whose duties shall be either Judicial, Executive or Administrative.**

5.01 Judicial Officials

1. The International Jury:

1. For International Meetings (refer to FIM/FIME Sporting Codes).
2. The Stewards of the Meeting:
 1. National: Up to three Stewards may be nominated.
 2. Open and Restricted: Stewards may be appointed according to the decision of the Permit Issuing Authority.
 1. National: The Permit Issuing Authority for all National meetings is ACU Ltd. As such all Stewards appointments will be made in accordance with the decisions of the respective ACU Sport Committee. Each National meeting will be looked at on a case by case basis and if the relevant Sport Committee decides it is necessary, then Stewards will be appointed.
 2. Open and Restricted: Stewards may be appointed according to the decision of the Permit Issuing Authority.
 3. Nomination of Officials
 1. Where applicable and as appropriate, a Sport Committee may nominate one or more Stewards at any ACU permitted event within the sporting discipline for which the Sport Committee is responsible, irrespective of the status of the meeting, and whether the ACU Headquarters or a Local Centre is the permit issuing authority for the meeting. A Local Centre may nominate up to three Stewards for any event for which it has issued a Permit. Where an event is organised by more than one Centre or an event transcends more than one Centre boundary, those affected Centres may appoint a Steward as appropriate to the nature of the event.
 2. A Local Centre may nominate Stewards for any meeting for which it has issued a Permit.
 3. A Local Centre may appoint a Steward for any Open or Restricted meeting if it is one of the participating Centres mentioned in the Supplementary Regulations for the event.
 3. The Referee:
 1. Where the Standing Regulations stipulate a Referee then he shall take the place of the Stewards and shall have the same responsibilities and authority.
 4. Race Direction
 1. Where a Race Director is appointed, they are empowered to take disciplinary action in accordance with article 6.02.2 and to adjudicate on any protest arising out of the meeting in accordance with Article 10.04.1.
 5. The Clerk of the Course:
 1. The Clerk of the Course is empowered to take disciplinary action in accordance with Article 6.02.2 and to adjudicate on any protest arising out of the meeting in accordance with Article 10.04.1.
 2. Appeals against the decision of the Clerk of the Course at Open and Restricted Meetings where no ACU Steward is present.
 1. For all Road Race events the Organising Club will appoint three Stewards to hear the Appeal on the day of the event.
 2. For all other events the ACU Secretariat will appoint Stewards to hear the Appeal after the event in conjunction with the Permit Issuing Authority.
 6. The Judicial Clerk of the Course
 1. For events where it may be deemed necessary et. International Road Race, a Judicial Clerk of the Course may be appointed.
 2. Where such a Judicial Clerk of the Course is appointed, he will assume the powers and responsibilities of the Clerk of the Course in all Disciplinary and Arbitration matters.

5.02 Executive and Administrative Officials

1. Race Director. The Race Director shall be the Chief Executive Official under whose direction the Executive and Administrative Officials listed under 5.02.2 may be appointed according to the type of competition.
2. Clerk of the Course. For all competitions without a Race Director, the Clerk of the Course

shall be the Chief Executive Official under whose direction the following Executive and Administrative Officials may be appointed according to the type of competition.

1. Executive Officials

1. The Event Director (Non Speed Events). Article 6.10 refers.
2. The Deputy/Deputies/Assistant to the Clerk of the Course
3. The Chief Timekeeper
4. The Chief Technical Officer (or Machine Examiner)
5. The Chief Marshal
6. The Chief Medical Officer
7. The Incident/Safety Officer
8. The Senior Sound Inspector

2. Administrative Officials

1. The Secretary of the Meeting
2. The Press Officer

3. With the exception of the Chief Medical Officer, The Secretary of the Meeting and the Press Officer, all the above named Officials and all other ACU licensed Officials shall be affiliated members of the ACU.

5.03 Assistants to Executive and Administrative Officials

1. Executive and Administrative Officials may have Assistant Officials such as Marshals, Trials Observers, Depot and Paddock Control Officers, Medical Personnel and First Aid assistants etc. who need not be members of the ACU.
2. The ACU reserves the right to require any category of Official to be subscribed members of the ACU and to be licensed to officiate.

5.04 Requirement to Sign-On

1. As soon as possible on arrival at an event and before commencing any duties all executive, administrative and assistant officials must sign the official signing-on forms provided by the Organisers. Any other person invited by the Organiser who may be involved in any activity other than purely as a spectator must be signed on before they participate in any activity or undertake any role.

5.05 Age Limits for Officials and Assistants

1. All event Executive and Administrative Officials shall be 18 years of age or over.
Marshals: All Assistant Officials whose function is to be carried out at the immediate track-side must be at least 16 years of age.
Trials Observers: Trials Observers must be at least 12 years of age.
2. Parental Agreement and responsible Persons: All Assistant Officials who are under 18 years of age must have obtained parental agreement to carry out the duty and the signing-on signature must be countersigned by someone who is responsible for the official at the event.
3. General: When using the services of minors (persons under 18 years of age) for any official duties at any event special attention must be given to any risks which may be associated with the duty, and to the previous experience of the official.

5.06 plural Appointments

1. A Steward of the meeting shall not undertake any other duties except Environmental Reporting. Exception Club Stewards may undertake other duties.
2. Other Officials may undertake several different duties for which they are qualified. The Clerk of the Course shall not undertake any other duty except Secretary of the meeting, Event Director, Start and Finish Marshal and Environmental Officer.

5.07 Incompatibilities

1. No Official acting in any executive capacity at any meeting other than a Club Restricted Trial shall be an Entrant, Rider or Passenger in that meeting. Stewards may not participate in the competition.
2. In a Club Restricted Sprint or Hillclimb event officials other than the Clerk of the Course and the Stewards are permitted to enter and compete in the event.

CHAPTER 6 TERMS OF REFERENCE AND DUTIES OF OFFICIALS

6.01 Stewards of the Meeting/Referee

1. All Stewards must be subscribed members of the ACU.
2. Stewards of the meeting exercise judicial authority over the running of the meeting according to the application of the Code and any Supplementary Regulations. The Stewards have no executive function. The Stewards have the power, either under their own initiative or at the request of the Clerk of the Course, for urgent reasons of safety or other unavoidable necessity, to postpone the start of a competition, modify the course, stop a competition prematurely or cancel the whole or part of a meeting. Such a decision shall not be subject to an appeal.
3. The Stewards form the only tribunal competent to adjudicate on an appeal arising out of a decision of the Clerk of the Course or other official of the meeting. They may give judgement on any appeal which may arise, subject always to such rights as are provided in this Code. They may also report such persons to the permit issuing authority for further disciplinary action.
4. The Stewards of the meeting are at all times required to have a quorum of Stewards present for making a decision as allowed under this regulation. All formal meetings of the Stewards shall be minuted.
5. If provided by the Standing Regulations then a Referee may take the function of the Stewards of the Meeting. In such case he will have the same authority and responsibilities.

6.01.1 quorum for Meeting of Stewards

1. At any meeting of the Stewards, the minimum number to form a quorum shall be as laid down in NSC 5.01. If the required number is not present, in the case of more than 1, those present shall appoint a temporary substitute or substitutes to achieve a quorum.
2. The Steward appointed by the Permit Issuing authority will be the Chairman of the Stewards. In his absence the most senior Steward present will assume his responsibilities and duties.

6.01.2 Stewards Reports

1. The Stewards shall prepare and submit a report on the meeting to the authority granting the permit. Such reports shall include details of penalties imposed, protests and/or appeals lodged and decisions taken, Environmental Provisions and respect of the Environment Code together with details of any incidents involving personal injury to participants, officials or spectators notified on the day and recommendations, if any, for future events. The Stewards' report must be submitted to the Permit Issuing Authority within 7 days of confirmation of the results.

6.02 Race Director

1. A Race Director will be appointed where appropriate by ACU Head Office only when an Event Management Committee and/or a Race Direction has been established for a particular National or above meeting or Series of meetings (SRs or championship conditions refer).
2. The Race Director is responsible for ensuring the proper observation of the regulations. Only after authorization by ACU Head Office, the Race Director will act as the Senior Clerk of the Course with overall responsibility for ensuring the correct and efficient running of the practices and races.
3. The Race Director shall work closely with the Clerk of the Course and where appropriate, the

Promoter. The Race Director may delegate responsibilities to the Clerk of the Course as he deems necessary.

4. The Race Director is also responsible for all communications between the Event Management Committee/Race Direction and the ACU Stewards.

6.03 Duties of the Race Director

1. The Race Director having been appointed in accordance with article 6.02 shall be responsible for:
 1. The overall responsibility for the general conduct and control of the events on the circuit, including judicial, in accordance with the Regulations and the programme.
 2. The Race Director must be present throughout practicing and the competition in order to carry out his specific duties. His duties are concluded when the results have been finalised, the protest times having expired, all protests dealt with, and any post event inspection of machines or components have been completed and reported upon. The Race Director may delegate his powers to a responsible person. Responsibilities and duties are:
 1. Ensure that all legal requirements and relevant regulations are complied with and that all equipment needed to do so is at hand as appropriate.
 2. Ensure all other Senior Officials are in place.
 3. The control of practices and the races, adherence to the timetable and, if he deems necessary, agreeing with Race Direction to modify the timetable in accordance with the Regulations.
 4. The stopping of any motorcycle in accordance with the Regulations.
 5. The stopping or neutralizing of practice or races in accordance with the Regulations if he deems it unsafe to continue and ensuring that the correct restart procedure is carried out.
 6. The starting procedure.
 7. The use of Safety cars/fast intervention vehicles.
 8. To ensure Race Control is adequately staffed and the staff are fully briefed on procedures.
 9. To ensure all trackside Officials are in place and carry out their duties in accordance with the Regulations.
 10. Inform the Chief Steward of any major incidents.
 11. Together with the Clerk of the Course, ensure the conditions of the track licence are fulfilled prior to the start of the first practice session or race and report to Race Direction.
 12. To ensure that any judicial action is taken as necessary.
 13. Together with the Clerk of the Course, to ensure that all medical, first aid, fire and ancillary services as may be required by the Permit Issuing Authority are on duty.
 14. Liaise with the Secretary of the Meeting in order that the circuit, competitors, sponsors, teams, press and commentators can be kept fully informed of all relevant information by means of event bulletins.
 15. Ensure that every Serious incident or accident during practice or the races is recorded.
 16. Ensure Race Direction is satisfied with arrangements and have all documentation they require.
 17. Arrange meetings with Race Direction as considered necessary.
 18. Arrange any riders briefings that are considered necessary and ensure all riders attend.
 19. To ensure that all judicial proceedings are properly convened in accordance with the Regulations and as part of Race Direction, adjudicate on all Protests and ensure an appropriate record of decisions is made and handed to the Secretary of the Meeting.
 20. Together with the Chief Technical Officer to ensure that each machine carries the proper identification marking in accordance with the programme.
 21. Ensure that procedures are in place to verify that the correct rider is on each machine and marshal the machines as necessary.
 22. Oversee the start of all races liaising with the Clerk of the Course and Start/Finish and

- startline Officials to ensure the start procedure is correctly adhered to by all competitors, teams and officials.
23. Be responsible for the verification of the identity of all riders and passengers, and that each of them has been correctly entered and that none of them is disqualified, suspended, excluded or otherwise ineligible from taking part in the competition.
 24. To receive reports of the Timekeepers and other Officials, together with any information as may be necessary, for the determination of the results.
 25. To ensure that any Codes of Practice or Conduct in force at the time are complied with and that all necessary permissions have been obtained and essential services notified where required.

6.04 Race Direction

6.04.1 Race Direction will comprise the following persons:

- Race Director
- Clerk of the Course
- Deputy Clerk of the Course (or 1 × other nominated Senior Official)
- Promoter representative (if applicable)
- ACU Steward (not to be included if Race Direction are meeting to adjudicate on any protest relating to infringements of this Code or the Regulations).

6.04.2 The quorum for a meeting of the Race Direction is three persons and each person has one vote. Decisions are based on a simple majority. Other persons with specialist knowledge may be invited to attend meetings of Race Direction.

6.04.3 The Race Direction will meet at any time required during the event.

6.04.4 The Duties of Race Direction are:

- To take decisions as provided in the Supplementary Regulations/Championship Conditions.
- To impose penalties for any infringements of the Regulations.
- To adjudicate on any protest relating to infringements of this Code or the Regulations.

6.05 Clerk of the Course

1. Subject to the provisions of Article 6.02, the Clerk of the Course is responsible to the Stewards of the meeting and to the Organiser for the good management and conduct of a competition held in accordance with this Code, its Appendices, the Supplementary Regulations and the Programme and for the direction and control of all Officials necessary for that purpose with the exception of the Stewards of the Meeting and the Race Director.

6.06 Duties of the Clerk of the Course

1. Subject to the provisions of Article 6.02, the duties of the Clerk of the Course are outlined as follows:
 1. The overall responsibility for the general conduct and control of the events on the circuit, including judicial, in accordance with the Regulations and the programme.
 2. The Clerk of the Course must be present throughout practicing and the competition in order to carry out his specific duties. His duties are concluded when the results have been finalised, the protest times having expired, all protests dealt with, and any post event inspection of machines or components have been completed and reported upon. The Clerk of the Course may delegate his powers to a responsible person.Responsibilities and duties are:
 1. Ensure that all legal requirements and relevant regulations are complied with and that all equipment needed to do so is at hand as appropriate.
 2. Ensure all other Senior Officials are in place.
 3. The control of practices and the races, adherence to the timetable and, if he deems necessary, agreeing with the Chief Steward to modify the timetable in accordance with the Regulations.

4. The stopping of any motorcycle in accordance with the Regulations.
5. The stopping or neutralizing of practice or races in accordance with the Regulations if he deems it unsafe to continue and ensuring that the correct restart procedure is carried out.
6. The starting procedure.
7. The use of Safety cars/fast intervention vehicles.
8. To ensure Race Control is adequately staffed and the staff are fully briefed on procedures.
9. To ensure all trackside Officials are in place and carry out their duties in accordance with the Regulations.
10. Inform the Chief Steward of any major incidents.
11. Ensure the conditions of the track licence are fulfilled prior to the start of the first practice session or race and report to the Chief Steward.
12. To ensure that any judicial action is taken as necessary.
13. To ensure that all medical, first aid, fire and ancillary services as may be required by the Permit Issuing Authority are on duty.
14. Liaise with the Secretary of the Meeting in order that the circuit, competitors, sponsors, teams, press and commentators can be kept fully informed of all relevant information by means of event bulletins.
15. Ensure that every Serious incident or accident during practice or the races is recorded.
16. Ensure the Chief Steward is satisfied with arrangements and have all documentation they require.
17. Arrange meetings with the Chief Steward and Stewards of the meeting as considered necessary.
18. Arrange any riders briefings that are considered necessary and ensure all riders attend.
19. To ensure that all judicial proceedings are properly convened in accordance with the Regulations and adjudicate on all Protests and ensure an appropriate record of decisions is made and handed to the Secretary of the Meeting.
20. Together with the Chief Technical Officer to ensure that each machine carries the proper identification marking in accordance with the programme.
21. Ensure that procedures are in place to verify that the correct rider is on each machine and marshal the machines as necessary.
22. Oversee the start of all races liaising with the Start/Finish and Startline Officials to ensure the start procedure is correctly adhered to by all competitors, teams and officials.
23. Be responsible for the verification of the identity of all riders and passengers, and that each of them has been correctly entered and that none of them is disqualified, suspended, excluded or otherwise ineligible from taking part in the competition.
24. To receive reports of the Timekeepers and other Officials, together with any information as may be necessary, for the determination of the results.
25. To ensure that any Codes of Practice or Conduct in force at the time are complied with and that all necessary permissions have been obtained and essential services notified where required.
26. Complete the Environmental Report where no Steward is appointed by the Permit Issuing Authority and ensure the Environmental Code is respected.

6.07 powers of the Race Director

1. Subject to the provisions of Article 6.02, a Race Director may at his own discretion:
 1. Postpone the start of a meeting or competition for reasons of safety or of force majeure.
 2. Stop a race or competition prematurely for reasons of safety or force majeure.
 3. Prevent any rider or passenger from starting if such action is considered to be necessary for safety reasons.
 4. Order the removal from the circuit, course or venue, any person refusing to obey the orders of an Official, or otherwise discipline such a person.

5. Report to Race Direction any rider/passenger or any other person considered guilty of misbehaviour or breaches of the Code or unfair practice or failure to comply with the Code or Supplementary Regulations, who have not been disciplined under Article 6.07.4 above.
6. Prevent from starting any rider/passenger who is considered not qualified to start.
7. Order any rider to be flagged off the course at any time during a practice or race whom he considers for any reason to be a potential source of danger, or whom he considers is in breach of racing discipline or the sound control regulations.

6.08 powers of Race Direction

1. To take such disciplinary action as may be deemed necessary on any rider, passenger or other person guilty of misbehavior, or breaches of the Code or unfair practice or failure to comply with the Code or Supplementary Regulations/Championship Conditions. In speed events any verbal notification of a penalty must be confirmed as soon as possible in writing. The document must give details of the offence as well as the penalty.

6.09 powers of the Clerk of the Course

1. Subject to the provisions of Article 6.02, a Clerk of the Course may at his own discretion:
 1. Postpone the start of a meeting or competition for reasons of safety or of force majeure.
 2. Stop a race or competition prematurely for reasons of safety or force majeure.
 3. Prevent any rider or passenger from starting if such action is considered to be necessary for safety reasons.
 4. Order the removal from the circuit, course or venue, any person refusing to obey the orders of an Official, or otherwise discipline such a person.
 5. Take such disciplinary action as he may deem necessary on any rider, passenger or other person guilty of misbehavior, or breaches of the Code or unfair practice or failure to comply with the Code or Supplementary Regulations/Championship Conditions. In speed events any verbal notification of a penalty must be confirmed as soon as possible in writing. The document must give details of the offence as well as the penalty.
 6. Report to the Chief Steward and Stewards of the Meeting any rider/passenger or any other person considered guilty of misbehavior or breaches of the Code or unfair practice or failure to comply with the Code or Supplementary Regulations, who have not been disciplined under Article 5 above.
 7. Prevent from starting any rider/passenger who is considered not qualified to start.
 8. Order any rider to be flagged off the course at any time during a practice or race whom he considers for any reason to be a potential source of danger, or whom he considers is in breach of racing discipline or the sound control regulations.

6.10 Event Director

1. For Non-Speed events only. An Event Director may be appointed. The Event Director will be in possession of a valid ACU Clerk of the Course/Stewards licence. In circumstances where an Event Director is appointed, the Event Director will have the same powers as the Stewards of the Meeting in regard to safety and force majeure and will be required to remain at the Control Centre for the duration of the event.

6.11 Duties of an Event Director

1. The Event Director has the power, either under his own initiative or at the request of the Clerk of the Course, for urgent reasons of safety or other unavoidable necessity, to postpone the start of a competition, modify the course, stop a competition prematurely or cancel the whole or part of a meeting. Such a decision shall not be subject to an appeal.

6.12 Event Safety Officer

1. An Event Safety Officer will be appointed where required by the Standing Regulations. The Event Safety Officer is to assist the Race Director/Clerk of the Course in planning, managing and reviewing the adequacy of event safety arrangements. As per NSC 6.02 and NSC 6.05, the Race Director/Clerk of the Course still retains executive responsibility for managing the safety of the event. The Event Safety Officer is more of an advisory role who has a knowledge of health and safety requirements, risk assessment and emergency planning.

6.13 Duties of an Event Safety Officer

1. Provide advice and assistance on Health & Safety matters/risk assessments/emergency planning and event management as appropriate.
2. Support the Race Director/Clerk of the Course in the development and review of the Event Safety Plan, Risk Assessments, Event Instructions and procedures to manage the risk.
3. Assist the Race Director/Clerk of the Course to verify that Event personnel, arrangements, Marshals, First Aid and Fire Safety are in place. Conduct dynamic Risk Assessments during the event if required, such as if the Course needs to be modified at short notice.
4. Conduct checks during the event to verify processes and procedures are working correctly and to monitor effectiveness.
5. Identify areas where safety/procedures may be improved.
6. Actively promote safety during events providing advice and support as required. Assist with/ lead the investigation into incidents/accidents/near misses and ensure a log is maintained of events/issues.

6.14 Secretary of the Meeting

1. The Secretary of the Meeting is the Official responsible for the administrative organisation of the meeting whose duties shall include responsibility for:
 1. The application to the appropriate authority for a permit.
 2. The drafting of the Supplementary Regulations (SRs) and Entry Forms.
 3. The distribution of the SRs.
 4. The recruitment of Officials.
 5. The engagement of all necessary services.
 6. The confirmation of entries received and compilation of a programme.
 7. The provision and distribution of all necessary badges, passes, armbands etc.
 8. The preparation and distribution of results. The submission and accuracy of any documents as may be returned to the Permit Issuing Authority.
 9. The collection and transfer of fees and insurances.
 10. All correspondence necessary for the efficient running of the administration of the meeting.
 11. To send reports to all Disciplinary matters to the Permit Issuing Authority.

6.15 Timekeeper

1. A qualified Official, appointed at the discretion of the Permit Issuing Authority, holder of an ACU Technical licence of a Grade appropriate to the status of the meeting and using apparatus of a type approved by the ACU.
2. Any other person using a timepiece or apparatus for the recording of time shall be known as a Time Marshal.
3. A Timekeeper will be considered a judge. When supplied by a Timekeeper, and apart from the correction of errors which may emerge on investigation, the times, speeds and classifications in a competition shall be taken as fact and no protest or appeal shall be accepted as to their accuracy.

6.16 Chief Medical Officer

1. The Medical Officer shall be qualified in accordance with the discipline requirements stipulated within the current ACU Handbook and shall satisfy himself that:
 1. Adequate arrangements, including First Aid staff and equipment, have been made for dealing with any casualties.
 2. He is accessible to the Clerk of the Course as appropriate.

6.17 Technical Official

1. A qualified Official, holder of an ACU Technical licence of a grade appropriate to the status of the meeting. Responsible for the enforcement of all Technical rules and specifications appearing in Appendix 'D' of the National Sporting Code, the discipline Standing Regulations and any Supplementary Regulations which may be issued for the competition. May act alone or control a team of Technical Officials. At the commencement of a meeting, all Technical Officials must report to the Clerk of the Course and 'sign-on' on the official signing-on sheet. They shall not communicate any official information to another person except as they may be required so to do in the performance of their duties.

6.18 Duties of Starter and Line Judges

1. The Clerk of the Course may undertake the duties of Starter or Line Judge, or he may appoint an Official or Officials to carry out these duties. In the case of a handicap competition, where the handicap is wholly or partly by time, the Starter shall be a Timekeeper.
2. The use by the Starter or by the Judge of mechanical appliances for facilitating starting or for recording finishes is permitted, provided that such apparatus has first been approved by the authority granting the permit.
3. No protest or appeal may be made against the decision of a Starter or Judge. A mistake made by a Judge may be corrected by him with the approval of the Stewards of the meeting.
4. The judges may perform one or both of the following duties:
 1. Starting Line Judges, whose duty is to point out any false starts to the Clerk of the Course immediately after they occur;
 2. Finishing Line Judges, whose duty is to declare the order in which competitors cross the finishing line.

6.19 Incident Officer

1. An Official who collates all appropriate information and documentation, and subsequently prepares all reports relating to serious incidents during a meeting.

6.20 Sound Inspector

1. A qualified Official, holder of an ACU Technical licence and having charge of Sound Control apparatus approved by the ACU, who is responsible for the measurement of Sound as per the Standing Regulations.
2. A Sound Inspector will be considered a Judge. When supplied by a Sound Inspector, and apart from the correction of errors, which may emerge on investigation, the results of the Sound Inspection shall be accepted as fact with no right of protest or appeal.

6.21 Trial Observer

1. An Observer is an assistant to the Clerk of the Course appointed to judge a competitor's performance in an observed section. No protest or appeal can be accepted against a judgement of performance made by an Observer, however a protest or appeal may be accepted against any breach or misinterpretation of the Regulations. A mistake by an Observer may be corrected by him with the approval of the Clerk of the Course and the Stewards of the Meeting.

6.22 Measurer

1. A qualified Official, holder of an ACU Technical Licence having charge of, or access to, measuring equipment, able to verify the engine or any other controlled part of the motorcycle on the instruction of the Clerk of the Course, or to determine a protest.
2. A Measurer will be considered a Judge. When supplied by a Measurer, and apart from the correction of errors, which may emerge on investigation, the results will be taken as fact from which there is no right of protest or appeal.
3. Measurers shall not communicate their findings to another person except as they may be required to do so in the performance of their duties.

6.23 Child protection

1. Event organisers must appoint a person (e.g. Secretary of the Meeting), to act as a point of contact for child protection issues and the appointed person should be named as such in the Supplementary Regulations for each event.
2. Should a Child Protection incident arise during an event, the appointed person must complete the Child Protection Incident Report Form and return the completed form to the General Secretary at ACU HQ within 7 days of the close of the meeting.

6.24 Officials Riding Motorcycles at ACU permitted Events

Motorcycle helmets, correctly fitted, must be worn by all riders and sidecar passengers when riding a motorcycle or Quad.

Officials must also wear a helmet whilst riding a motorcycle, and it is further recommended that they wear a helmet whilst riding a Quad.

CHAPTER 7 ENTRANTS, RIDERS AND PASSENGERS**7.01 Entrant**

1. Any person or corporate body holding a licence issued by or recognised by the ACU Headquarters, which entitles the holder to enter a competitor in a competition under the name of the licence holder.

7.02 Rider

1. The Person responsible for the control of the motorcycle and who must be either:
 1. A member of an Affiliated Local Motorcycle Club or Non-Territorial Motorcycle Club who is the holder of a Competition Licence or Trials Registration issued by the ACU or SACU valid for the type of event in which he/she wishes to compete, or, if appropriate, has paid an entry subscription, or
 2. A holder of a licence issued by a FIM member Federation. N.B. The term Rider to include the Driver of a Sidecar.

Note: The term Rider to include the Driver of a Sidecar.

7.03 passenger

1. The Person who accompanies a rider in a competition for Group B machines and who must be either:
 1. A member of an Affiliated Local Motorcycle Club or Non-Territorial Motorcycle Club who is the holder of a Competition Licence or Trials Registration issued by the ACU or SACU valid for the type of event in which he/she wishes to compete, or, if appropriate, has paid an entry subscription, or
 2. A holder of a licence issued by a FIM member Federation.

7.04 Age of Rider and passenger

1. The age of a rider or passenger shall be as laid down in the appropriate discipline Standing Regulations.

7.05 Licensing of Riders and passengers

1. All persons ordinarily resident in England, Wales, the Channel Islands or the Isle of Man wishing to compete as a rider or passenger in an event as described in Chapter 3 must hold a current Competition Licence, unless an entry subscription scheme has been agreed by the ACU for the discipline concerned. Persons resident in Scotland shall apply to the Scottish ACU for licences where applicable.

7.06 Entrant's Licence

1. An Entrant's licence entitles the holder to enter a qualified competitor in any competition of a status up to that authorised on the licence, but does not permit the holder to ride or be a passenger in any such competition unless they also are qualified to ride or to act as a passenger.

7.07 Rider's Licence

1. A rider's licence entitles the holder to enter and ride in a competition of a status up to that stated on the licence, but does not permit the holder to nominate any other licensed rider as a replacement.

7.08 passenger's Licence

1. A passenger's licence entitles a holder to accompany a qualified licensed rider in a competition for Group B machines, as may be required by the Standing Regulations but does not permit the holder to ride a motorcycle in competition.

7.09 One Event Licence

1. A One Event Licence entitles the holder to enter and ride in a competition at the event at which the one event licence has been purchased.
The One Event Licence is valid only at the event for which the licence has been purchased. If the rider is not a member of a Club eligible to enter that event, the Organiser may enrol the rider as a member of that Club, for which a fee may be charged.

7.10 Licences – Status and Validity

1. Refer to the current edition of the ACU Handbook for details of current structure of licences according to Class, Grade and Activity.

7.11 Refusal or Withdrawal of Licence

1. The ACU may refuse to issue, or may withdraw any licence, without giving reason, subject to the right of appeal provided for in Chapter 10 of this Code.

7.12 production of Competition Licence or Trials Registration

1. All Entrants, Riders or Passengers shall carry their current Competition Licence or Trials Registration and must be prepared to produce either document when signing on at a meeting.
2. Any Rider or Passenger in possession of a current Competition Licence or Trials Registration (to the knowledge of the Organiser) but unable to produce it when signing on will be permitted to take part in the meeting but will be subject to a fine, payable to the ACU Benevolent Fund. The amount of the fine will be found listed in the current edition of the ACU Handbook under "Price List".
3. Any Rider or Passenger not in possession of a current Competition Licence or Trials Registration may be permitted to take part in the meeting subject to the decision of the Clerk of

the Course. The Clerk of the Course will take into account the conditions relating to the issue of such a Competition Licence or Trials Registration and whether or not it is practicable to arrange for a completed Licence or Registration application form at the event.

A One-Day Licence may be issued where valid for the status of the event and the discipline concerned.

4. If a late application for a Competition Licence or Trials Registration is approved by the Clerk of the Course and the Licence or Registration Fee is paid together with a fine for non-production of the Licence or Registration, described in Article 7.11.2 above, the competitor will be permitted to take part in the meeting.
5. The Clerk of the Course and the Stewards of the Meeting have no power to permit an unlicensed rider or passenger to take part in a competition for which riders and passengers must be licensed.

7.13 Technical Inspection

1. All special aspects of machines, helmets, clothing, and any other material items as specified by this Code and any other Standing Regulations or Final Instruction shall be subject to examination prior to the start of practice/competition.

7.14 Signing On/Signing Off

1. At all competitions, all riders and passengers must sign on and sign off, where directed within the Regulations.

7.15 Mutual Responsibility of Entrant, Rider, parent/Legal Guardian

1. An Entrant and/or rider shall be responsible for all acts or omissions on the part of his riders, mechanics, passengers or any member of his entourage, but each of these shall be equally responsible for any infringement of this Code. A parent or legal guardian of a rider or passenger participating in a competition requiring consent, is deemed to bear mutual responsibility with that competitor.

7.16 Assumed Name

1. A person shall not take part in any competition under an assumed name unless special permission for the use of such assumed name has been granted by the ACU Headquarters. In such cases a licence will be issued in the assumed name, if approved, on payment of an additional fee. The licensee, for so long as he is registered under an assumed name, shall not take part in any competition under any other name, and shall not revert to the use of his own name until he has obtained a fresh licence in his own name from the ACU Headquarters.

7.17 Change of Rider, passenger or Motorcycle

1. It is not permitted to change a rider, passenger, make or capacity of motorcycle, after the start of any meeting unless such change is authorised in the appropriate discipline Standing Regulations.
2. Unless specifically prohibited, or otherwise provided for in the Standing Regulations, change of rider, passenger or the make or capacity of motorcycle may be considered by the Secretary of the meeting after entries have closed, provided the entrant notifies him, in writing, at least 24 hours before the official starting time of the competition of some good and sufficient reason why, the entered rider or passenger is unable to take part in any competition on that date, or why the entered motorcycle cannot be produced on that date.
3. If the composition of any team is affected by an authorised change as above, the entrant of that team or his representative may, up to the official starting time of the competition, replace the rider so affected by any other entered riders otherwise eligible for the team.
4. A change of both rider and make of motorcycle is not permitted unless the authority granting

the permit has specifically approved the Supplementary Regulations providing for such changes being made.

5. In a competition, a substitute rider may be nominated only by a licensed entrant.

7.18 Conduct of Riders

1. Any rider who, having entered in any competition, does not make a bona fide attempt to succeed may be deemed to be guilty of a breach of this Code.

7.19 Irregular Entries

1. Any rider or passenger who has entered a competition and does not participate therein, but participates or has been entered in another competition at another meeting on the same day shall be in breach of this Code.

7.20 Absentees

1. Unless it can be justified, the absence of any competitor who has entered a competition and is not present at the start shall be in breach of this Code.

7.21 Withdrawal of Entry

1. The Entrant/Rider may only withdraw the entry with the permission of the organiser.

7.22 Finish of a Meeting and prize Giving

1. A meeting is not considered to be finished until the time-limits for protests and appeals have elapsed and all protests and appeals have been settled. If an appeal is lodged, the results cannot be considered as definitive until a final decision has been taken. The riders placed first, second and third will be asked to attend the official prize giving ceremony, if any. Where the results are announced at the meeting the race control must remain operative with all equipment in place until the end of the period for lodging a protest. All officials and marshals must remain at the circuit and be available to the Clerk of the Course and the Stewards of the Meeting.

CHAPTER 8 COURSES AND PUBLIC SAFETY

8.01 Courses

1. The route to be followed by a competitor in a competition, including record attempts, shall be subject to the approval of the authority issuing the permit.

8.02 permission to Use Land

1. No competition shall be promoted on either a public or private road, track or elsewhere until the Organisers have obtained the necessary lawful authority from the appropriate public authorities or private individuals and landowners; and except for Road Race, Supermoto, Drag or Sprint meetings to be held on courses which are subject to Permanent Course Licences, have consulted with the permit issuing authority.

8.03 Measurement of Distance on the Course

1. Distances up to 5 kilometres shall be measured along the centre line of the course by a competent Official; distances over 5 kilometres shall be determined by means of the Ordnance Survey map of a scale of not less than 1:250.000.

8.04 Licensing of Courses for Speed Events

1. All courses for Speed Events staged in accordance with this Code, whether permanent or temporary, must be licensed or certified by the ACU.
2. In the case of Speed events under the jurisdiction of the Road Race Committee where the

arrangements for marking or enclosing the course are permanent or semi-permanent; and where there is permanent or semi-permanent accommodation, such as stands etc. for the public, Permanent Course Licences will be issued to the owner, or operator of the course. Where the licence holder is not the owner, a written agreement shall exist between the owner and the licence holder setting out the responsibilities of each to ensure that all requirements of the Course Licence are met.

3. In all other cases, a Temporary Course Certificate will be issued to the organising Club or Local Centre in whose territory the course is situated.
4. No course shall be used for an ACU Permitted meeting until a Permanent Course Licence or Temporary Course Certificate has been issued by the ACU Headquarters or its designated official, which may grant, refuse, withhold, suspend or revoke a licence or certificate at its discretion. A Permanent or Temporary Course inspection shall be valid for 1 year from the date of issue subject to payment of an annual Licence or Certificate fee according to the scale of fees that apply from time to time and subject to the conditions applicable to the issuing of the licence or certificate.

8.05 Application for permanent Course Licence

1. An application for a Permanent Course Licence must be made on the prescribed form, either direct to the ACU HQ or through the Local Centre to the ACU HQ as appropriate, and be accompanied by the annual fee as specified in a schedule of fees reviewed annually.
2. A plan of the Site giving Ordnance Survey Map reference numbers, based on Ordnance Survey Maps 1:50,000 Series with a 6 figure map reference or showing in sufficient detail, the existing or proposed course, together with details of length, direction of racing, measures for the protection of the public, and such other information as required on the Application Form, shall also be submitted.

8.06 Validity of permanent Course Licence or Temporary Course Certificate

1. A course licence or certificate is valid only where a Permit has been issued by the ACU Permitting authority. The licence or certificate shall not have any validity on any day nor at any activity for which an ACU Event Permit is not in force. A course licence or certificate is to be read in conjunction with and be deemed to incorporate all and any terms, conditions and provisions contained within or set out within the Permit.
2. The ACU may refuse, withhold, suspend, revoke a licence or certificate at its discretion.

8.07 Display of permanent Course Licence

1. A Permanent Course Licence must be prominently displayed at the course for which it is issued.

8.08 Application for Temporary Course Certificate

1. An application for a Temporary Course Certificate must be made on the prescribed form, through the Local Centre to the ACU Headquarters, and be accompanied where appropriate by the annual fee as specified in a schedule of fees reviewed annually, and by site information as required under Art. 8.05.
For Grass and Sand Track races the plan need only specify location, site access details and any special measures for the protection of the public.

8.09 Availability of Temporary Course Certificate

1. The Temporary Course Certificate should be available for inspection at the circuit for which issued prior to commencement of practice or racing.

8.10 Responsibility of Licence/Certificate Holder and Organiser

1. Where the Licence/Certificate holder is not also the organiser of a meeting, an agreement,

approved by the ACU Headquarters, shall be completed between the Licensee/Certificate holder and the organiser, detailing the division of responsibility for carrying out the requirements of the licence/certificate and of the organisation of the meeting.

8.11 Alteration to Conditions

1. No alteration to the requirements contained in a Permanent Course Licence or Temporary Course Certificate shall be made without the prior approval in writing of the ACU Headquarters or, in the case of unavoidable necessity, by the Stewards of the Meeting. In the latter case details of the alterations permitted must be given immediately after the meeting to the authority granting the permit.

8.12 Course Inspection

1. Each course for which application is made for a Permanent Course Licence or Temporary Course Certificate, shall be inspected by an Official appointed by the ACU Permit issuing authority. The general conditions governing the safety of the public shall be as laid down in "Safety Precautions" within the current edition of the ACU Handbook and as further detailed on the Permanent Course Licence or Temporary Course Certificate, together with the maximum number of competitors permitted in any one race. The direction of racing must be shown.

8.13 Re-Inspection and Amendment of Licence or Certificate

1. The ACU Permit issuing authority reserves the right to re-inspect a course at any time and to amend the conditions or requirements of a Permanent Course Licence or of a Temporary Course Certificate.

CHAPTER 9 ANTI-DOPING, ALCOHOL AND MEDICAL

9.01 Anti-Doping

1. Doping is the occurrence of one or more of the anti-doping rule violations which are:
 - The presence of a prohibited substance or its metabolites or markers in a rider's bodily specimen.
 - The use or attempted use of a prohibited substance or a prohibited method.
 - The possession of prohibited substances and methods.

9.02 prohibited Substances and Methods

1. The ACU list of prohibited drugs is the list agreed by UK Sport and WADA and published by them and also in the FIM Anti-Doping Code.

9.03 Rules for the Enforcement of Anti-Doping

1. The ACU Headquarters or UK Sport may order drug tests at any meeting organised under the jurisdiction of the ACU.
2. The riders or passengers to be tested must report to the Doping Control Officer (DCO) with their licences within one hour of the rider being notified, or within one hour after the finish of the last race in which the rider or passenger took part. One chaperone may accompany the rider or passenger.

9.04 Testing procedure

1. The testing procedures to be used at ACU events will be commensurate with any current legitimate procedure adopted and carried out in the UK.

9.05 Costs for Anti-Doping Tests

1. The cost of the primary tests will be paid by the ACU. In the case of a competitor requesting a second test, he/she should deposit a sum equal to the ACU appeal fee with the ACU. If the second test is negative, the deposit shall be returned.

9.06 Sanctions

1. Sanctions are imposed against the competitor:
 - whose tests prove positive
 - who refuses to undergo a test or who does not report to the drug test centre when notified to do so.

9.07 penalties

1. The minimum penalty for a first offence will be a two year suspension. For subsequent offences suspension may be imposed (see article 10.02.1). For tests that prove positive, penalties will be imposed with immediate effect. Affected individuals may appeal in accordance with Chapter 10 of this Code. Should an individual wish to appeal, the original suspension put in place would remain extant until the Appeal is heard. The Appeal fee for an appeal against a suspension resulting from a positive drugs test is £3,000. Should an individual request that the original sample taken be re-tested at an alternative laboratory, the costs of that re-test would be borne by the individual. All costs associated with the Appeal to be borne by the affected individual and would not be refunded unless the Appeal was upheld.

9.08 Alcohol

1. Tests may be carried out, on any participant at an event, prior to practice or a race or at any time during the event by means of the standard breath test system. A nominated Breath Alcohol Technician will carry out the tests. A positive breath test or a refusal to undergo a test will result in disqualification from the event as a minimum sanction. The permitted level of alcohol is 0.10g/L.

9.09 Medical Examination/Testing

1. At any time during an event the Race Director/Clerk of the Course or the Chief Medical Officer may request a Medical Examination or an Approved Swab Test to be carried out on any competitor or Official to test for the use of recreational drugs. Should a test prove positive, the competitor/Official will be disqualified/suspended from any form of competition/their respective activities for the remainder of that event. Any competitor or Official who refuses to participate in a medical examination/approved Swab Test will be disqualified/suspended from any form of competition/their respective activities for the remainder of that event. Details of any medical examination/testing/non-compliance to examination/testing will be reported to ACU Headquarters. On receipt of such a report, ACU Headquarters may decide to:
 - Request the individual to undergo further tests, the costs associated with any test to be borne by the competitor/Official.
 - Suspend the competitor/Official from further ACU competition/ACU activity for a period of time not exceeding those penalties outlined in NSC 9.07.
 - Convene a Sport Committee Hearing/Court of Enquiry in accordance with NSC Chapter 10.

CHAPTER 10 DISCIPLINARY AND ARBITRATION CODE

10.01 principles

1. **Trials and Enduro only.** It should be noted that non-disciplinary decisions of the Clerk of the Course (e.g. course changes, observer's decisions and the like are dealt with by direct Appeal to the Stewards. Appendix B of this Chapter refers.

2. The duties, powers and responsibilities of the bodies and delegates of the ACU are set out in the ACU Rules and Bye-Laws.
3. Similarly, the obligations incumbent upon the participants, officials and organisers of sporting events are set out in the ACU National Sporting Code (NSC) and in any other rules and regulations which are or may be introduced and published by the ACU.
4. Proven violation or non observance of these obligations will be subject to the penalties laid down in this Disciplinary and Arbitration Code.

2. DATE OF APPLICATION

1. This Code cancels and replaces all prior publications.
2. Changes may be made to this code each time the ACU deems it necessary as a result of experience or evolution.

10.02 penalties

1. The penalties are:
 - Warnings
 - Licence withdrawal or amendment
 - Fines
 - Time penalties
 - Place Penalties
 - Point Penalties
 - Disqualification
 - Withdrawal of Championship points
 - Suspension
 - Exclusion

10.02.1 Definition and application of Penalties

Warnings Can be made privately or publicly.

Licence Withdrawal or Amendment The withdrawal or amendment of the terms or conditions appertaining to any ACU licence.

Fines Cash penalty (see also Art.10.02.2.2 below)

Time and/or point penalty or suppression of time The imposition of time or points affecting the rider's actual result or suppression of time.

Disqualification Entails automatically and independently of any other penalty, the invalidation of the results obtained in a meeting, event, practice, race or ranking there from.

Withdrawal of Championship points Entails the loss of Championship points.

Suspension Entails the loss of all rights granted to ACU members or Licence Holders, or prohibition from taking part in any of the activities under ACU control for a specified period of time. The application of this penalty may be conditionally deferred for a period of up to a maximum of two years.

Exclusion Entails the final and complete loss of all rights of participation in any activity under ACU control.

10.02.2 Specific Penalties

1. Specific penalties for certain offences are provided for in the NSC the Appendices, Regulations, and/or Supplementary Regulations.
2. Fines will not normally be awarded against Voluntary Officials.

10.02.3 Plurality of Penalties

1. Any offender may have several penalties pronounced against him according to the circumstances.

2. Certain penalties entail suspension of the ACU Licence or Registration until the penalty inflicted has been fulfilled.

10.03 The ACU Disciplinary and Arbitration Bodies

10.03.1 The Judicial panel

1. The Panel is composed of three Members as follows: General Secretary
Two Directors appointed by the Board

10.03.1.2 Authority

1. The Judicial Panel have the power to penalise any voluntary or involuntary act or deed made by an ACU Licence holder or Official in cases of:
any proceeding or act prejudicial to the interests of, any part or body of the ACU, or a proceeding or act which brings the ACU or motorcycle sport into disrepute;
any fraudulent act or proceeding in connection with a competition or of the sport of motorcycling generally;
a Statement of Fact received from an Executive Official of the Meeting; where there is an admittance of guilt from the alleged offender;
where there is a continued threat of violence which may threaten the safety of others.
2. The Judicial Panel have the authority to impose a penalty without the alleged offender being present.

10.03.1.3 Penalties that may be imposed by a Judicial Panel

1. The following penalty may be imposed by the Judicial Panel without prejudice to Articles 10.02 and 10.03.
A suspension – subject to a maximum period of up to 90 days. A fine – subject to a maximum of £500.
The alleged offender has no right of appeal.

10.03.2 The ACU Sport Committees

10.03.2.1 Authority

1. The ACU Sport Committees have the power to penalize any voluntary or involuntary act or deed made by an ACU Licenced Official appointed to the event, an ACU Licence Holder/Trials Registered Rider, mechanic, passenger, or any member of the ACU Licence Holder's/Trials Registered Riders entourage in the case of proven violation or non-observance of Regulations.
2. In all such cases, the Sport Committee will convene a Hearing to which the alleged offender has the right to appear before the Committee at the time of a Hearing or to elect that the case be heard in his absence.

10.03.2.2 Penalties that may be imposed by a Sport Committee

1. The following penalties may be imposed by the Sport Committees without prejudice to Articles 10.02 and 10.03. A
Warning
A fine up to a maximum of £500
A licence withdrawal or amendment
2. Furthermore, the Sport Committees can refer the case to the Judicial Panel in order to impose a higher penalty than the Sport Committee is empowered to do.

10.03.3 The Clerk of the Course

10.03.3.1 Appointment

1. Subject to the provisions of Article 6.02, the Clerk of the Course is the person appointed to exercise supreme control of the meeting.

10.03.3.2 Authority

1. Subject to the provisions of Article 6.02, the Clerk of the Course has the authority to penalize automatically:
11 Any voluntary or involuntary act or deed made by an ACU Licenced Official appointed to the event, an ACU Licence Holder/Trials Registered Rider, mechanic, passenger, or any member of the ACU Licence Holder's/Trials Registered Riders entourage in the case of proven violation or non-observance of Regulations.
12 Any corrupt or fraudulent act, or any action prejudicial to the interests of the meeting or of the sport, carried out by a person or ACU Licence Holder(s) during a meeting.
13 The Clerk of the Course is empowered to adjudicate upon any protest lodged during a meeting.

10.03.3.3 Penalties that may be imposed by the Clerk of the Course

1. Subject to the provisions of Article 6.02, the following penalties may be imposed by the Clerk of the Course without prejudice to Articles 10.02 and 10.03:
A warning
A time penalty
A place penalty Points
penalty
A stop and go penalty
A ride through penalty The Black Flag
A fine, subject to a maximum of £500
Disqualification (black flag, black flag with orange disc – disqualification from the event, practice or results).
A withdrawal of championship points
2. Furthermore the Clerk of the Course can refer the case to the Judicial Panel in order to impose a higher penalty than he is empowered to do.

10.03.4 The Steward(s) of the Meeting

10.03.4.1 Appointment

1. The Steward(s) of the Meeting are appointed according to the requirements laid down in Chapter 5 of the ACU National Sporting Code.

10.03.4.2 Chief Steward

1. According to this Code the ACU enjoys the same rights and obligations as the other parties.
2. The ACU may be present in person at a hearing or may present its claims in writing.
3. When appointed by the permit issuing authority a Steward will act as the Chief Steward and will chair all meetings of the Steward(s). In the case of equality of votes he will have an additional casting vote.

10.03.4.3 Authority

1. The Steward(s) will hear any appeal arising from decisions taken by the Clerk of the Course in judging any Protest at a Meeting.

10.03.4.4 Penalties that may be imposed by the Steward(s) of the Meeting only following an Appeal

- A warning
- A fine – subject to a maximum of £500
- A time penalty
- A place penalty
- Points penalty
- A disqualification
- A withdrawal of Championship Points
- A suspension – subject to a maximum period of 30 days

Furthermore, the Steward(s) may refer the case to an ACU Court of Enquiry (COE) in order to impose a higher penalty than the Stewards are empowered to do.

10.03.5 The panel of Adjudicators (pOA)**10.03.5.1 Composition**

1. The Panel of Adjudicators is composed of twelve persons elected by the National Council for a period of three years commencing on the 1st January in any year. A maximum of three will be appointed to hear any appeal.

10.03.5.2 Authority

1. The Panel will hear appeals against non-disciplinary decisions of Sport Committees or Local Centres.

Decisions of the Panel of Adjudicators are final.

10.03.6 The Judicial Enquiry

1. The Judicial Enquiry is composed of persons from which the members of ACU National Courts are nominated.

10.03.6.1 Constitution

1. The Judicial Enquiry shall consist of:
 - A qualified legal adviser appointed by the Board of Directors (BOD) of the ACU.
 - Members nominated by the Board of Directors and Main Committees of the ACU.
 - Members of the Panel of Adjudicators.

10.03.6.2 procedures

1. The General Secretary having established that the procedures have been followed and/or that the case can be heard will appoint members to form the appropriate disciplinary or arbitration body. The names of the members appointed must be communicated to all interested parties in the case.

10.03.7 The ACU as a party in the Judicial proceedings**10.03.7.1 Function**

1. In all proceedings before an ACU Court the Board of Directors (BOD) of the ACU or the relevant Sport Committee is entitled to assert its interests by means of a prosecution address.

10.03.7.2 Appointment

1. The Board of Directors (BOD) of the ACU or the relevant Sport Committee shall appoint a person who will represent the ACU.

10.03.7.3 Procedure

1. The intervention of the ACU is optional and is left to the discretion of the Board of Directors (BOD) of the ACU or the relevant Sport Committee.

10.03.8 ACU Courts of Enquiry (COE)

10.03.8.1 National Court

10.03.8.2 Composition

1. For each case the National Court is made up of 3 members from the judicial panel appointed by the General Secretary of the ACU.

10.03.8.3 Authority

1. The National Court will hear any appeals against decisions taken by the Stewards of a Meeting.
2. The National Court adjudicates in the first instance upon request of the Board of Directors (BOD) of the ACU, the Sport Committees or other competent bodies of matters of violation or non-observance of the ACU rules and regulations.

10.03.8.4 ACU Local Centre Courts

10.03.8.5 Composition

1. For each case the Local Centre Court is made up of 3 members appointed by the Management Committee of the Local Centre in accordance with the Local Centre Bye-Laws.

10.03.8.6 Authority

1. The Local Centre Court adjudicates upon any dispute or complaint or disciplinary matter in connection with any of its affiliated Clubs or Members of such Clubs.
2. The Local Centre Court also adjudicates upon any matter referred to it by the Stewards of any meeting for which the Centre was the Permit Issuing Authority (PIA).

10.03.8.7 Scottish ACU Court

10.03.8.8 Authority

1. A court appointed by the Scottish ACU shall adjudicate upon any complaint or disciplinary matter arising within the territory of the SACU.

10.03.9 The ACU Final Tribunal of Appeal (FTA)

10.03.9.1 Composition

1. The tribunal is composed of three members appointed by the General Secretary of the ACU at least one of whom will be legally qualified. No member who previously dealt with the case in question may be appointed.
2. The Tribunal is the final appeal body of the ACU against any decisions taken by an ACU Court.

10.04 protests and Appeals

10.04.1 Right of Protest

1. Save for Articles 6.13, 6.16, 6.18 and 6.20; Any person, a rider/passenger in possession of a current valid competition licence and/or a team, sponsor, manufacturer, official etc. being the holder of an ACU licence and directly affected by a decision taken during a meeting under the authority of the ACU or following dangerous, unfair or fraudulent behaviour, riding or act, has the right to protest against such a decision, behaviour, riding or act.
2. No protest can be lodged against a statement of fact pronounced by the Clerk of the Course

or any other executive official. Statements of Fact are defined in the relevant Appendices and Regulations.

10.04.2 Withholding of Prizes and Awards in case of Protest or Appeal

1. Any Award gained by an entrant, rider or passenger against whom a protest or appeal has been lodged shall be withheld until the protest or appeal has been adjudicated upon and the time for any further appeal has expired without notice of appeal having been given.

10.04.3 Procedure and time limit for Protests

1. All protests must be submitted in writing and signed only by the person directly concerned.
2. Protests must refer to a single subject only and must be presented within 30 minutes at the latest of the publication of the results unless otherwise defined in the relevant Appendices and Regulations.
3. During a meeting, protests must be submitted according to the provisions of the Supplementary Regulations and handed to the Clerk of the Course or Secretary of the Meeting together with the correct protest fee.
4. Any Protest against the eligibility of a rider, passenger, team or a motorcycle entered must be made before the start of the official practice unless otherwise defined in the relevant Appendices and Regulations.
5. Any protest against machine conformity ie. sound, fuel or any other technical breach must be received before the cessation of active competition.

10.04.4 Protest Fees

1. The Protest Fee at an International Meeting held under an ACU Permit is £150. The Protest Fee at any other meeting under an ACU permit is £100.

10.04.5 Hearing a Protest

1. After a hearing, the Clerk of the Course must make a decision on any protest presented during a meeting. The protest has to be judged according to the provisions of the ACU National Sporting Code and its Appendices and the Supplementary Regulations of the Meeting.

10.04.6 Effect of the decision of the Clerk of the Course

1. The decisions of the Clerk of the Course on the determination of penalties are immediate.

10.04.7 Right of Appeal

1. The provisions concerning appeals against ACU disciplinary decisions incurring one of the penalties stated in Article 10.02 are as follows:
 1. Against the decision of a Sports Committee in a disciplinary matter to the COE.
 2. Against the decisions of the Clerk of the Course following a protest to the Stewards of the Meeting.
 3. Against the decision of the Judicial Clerk of the Course following a protest to the Stewards of the Meeting (International competition).
 4. Against the decisions of the Stewards of the Meeting to the COE. (or LCC where the Centre is the PIA).
 5. Against the decision of the LCC to the COE.
 6. Against the decision of the Scottish ACU to the COE.
 7. Against the decisions of the COE to the FTA.

10.04.8 Procedure and Time limits for the lodging of Appeals

1. All appeals must be submitted in writing and signed only by the person directly concerned.
2. During a meeting, appeals against a decision of the Clerk of the Course must be presented

in writing to the Stewards within 30 minutes and must refer to a single subject only and be accompanied by the correct appeal fee.

3. The time limit for lodging a statement of appeal is:

Against a decision of the Clerk of the Course to the Stewards of the Meeting:	30
minutes (Time limits for Appeals in respect of Trials and Enduro appear in Appendix B)	
Against a decision of the Judicial Clerk of the Course to the Stewards of the Meeting (International competition)	30
minutes	
Against a decision of the Stewards of the Meeting to the COE	5
days	
Against a decision of a Sports Committee in a disciplinary matter to the COE	5
days	
Against a decision of the COE to the FTA	5
days	
Against a decision of a Centre Court to the COE	5
days	
Against a decision of the Court of the Scottish ACU to the COE	5
days	
Against a decision of a Sport Committee to the Panel of Adjudicators	5
days	
Statement of appeal before the National Sport Dispute Resolution Panel	5
days	
4. The time limit shall be taken from the time or date of receipt of the decision appealed against.

10.04.9 Lodging of an Appeal to a Local Centre Court

1. Where the Permit Issuing Authority was a Local Centre Appeals arising out of the meeting will be heard by a Local Centre Court. In all such cases a further right of Appeal exists to the COE.
2. To be admissible, the statement of appeal must be sent by Special Delivery letter or special courier to the Secretary of the Permit Issuing Authority (Local Centre) and be postmarked within the deadlines specified in Article 10.04.8.
3. The correct appeal fee must be paid in to the Secretary of the Permit Issuing Authority within the deadlines specified in Article 10.04.8.
4. Within 10 days following the statement of appeal the appellant assigns to the Secretary of the Permit Issuing Authority a brief of appeal stating the facts.
5. If the Local Centre Court (LCC) appeal was not lodged and/or the appeal fee not paid within the deadlines specified in Article 10.04.8 the Secretary of the Permit Issuing Authority is empowered to declare the appeal inadmissible without hearing.

10.04.10 Lodging of an Appeal to the COE/FTA/POA

1. To be admissible, the statement of appeal must be sent by Special Delivery letter or special courier to the General Secretary of the ACU and be postmarked within the deadlines specified in Article 10.04.8. The correct appeal fee must be paid in to the General Secretary of the ACU within the deadlines specified in Article 10.04.8.
2. Within 10 days following the statement of appeal the appellant assigns to the General Secretary of the ACU a brief of appeal stating the facts.
3. If the COE/FTA/POA appeal was not lodged and/or the appeal fee not paid within the deadlines specified in Article 10.04.8 the General Secretary of the ACU is empowered to declare the appeal inadmissible without hearing.

10.04.11 Appeal Fees

1. The appeal fee is determined by the Board of Directors (BOD) of the ACU.
2. The fee for an appeal against a decision of the Clerk of the Course to the Stewards of the Meeting is £100.
3. The fee for an appeal against a decision of the Judicial Clerk of the Course to the Stewards of the Meeting (International competition). Refer to Appeal Fees outlined in the Price List printed in this Handbook.
4. The fee for an appeal against a decision of the Stewards of the Meeting, to the Local Centre Court is £150.

5. The fee for an appeal against a decision of the Stewards of the Meeting or the Local Centre Court to the COE or the Scottish ACU is £300.
6. The fee for an Appeal against a decision of a Sports Committee in a disciplinary matter to the COE is £300.
7. The fee for an appeal against a decision of the COE to the FTA is £5000.
8. The fee for a first appeal by a Licensed Official/competitor against a decision of a COE to the FTA is £500.
9. The fee for an appeal against the suspension of a competition licence resulting from a confirmed positive drugs test is £3,000.

10.04.12 Fees Payable upon an Adjournment

1. If an adjournment to call further witnesses is ordered upon the request of one of the parties involved, this party must provide an additional financial guarantee within a time limit to be fixed by the disciplinary body. The hearing will not be continued until this guarantee has been paid. In case of no provision of the guarantee within the time limit, the disciplinary body will make a determination of the appeal based on the evidence of the original witnesses.

10.04.13 Fees Payable upon Withdrawal of an Appeal

1. If an appeal is withdrawn prior to a hearing the appeal fee will be forfeited.

10.04.14 Time Limits for the Hearing of Appeals

1. The time limit for the hearing of appeals is:

Against a decision of the Clerk of the Course to the Stewards of the Meeting:	Same
day (Time limits for Appeals in respect of Trials and Enduro appear in Appendix B)	
Against a decision of the Judicial Clerk of the Course to the Stewards of the Meeting	Same
(International competition)	
Against a decision of the Stewards of the Meeting by the COE	4
weeks Against the decision of a Sports Committee in a disciplinary matter to the COE	4
weeks Against a decision of the COE to the FTA	8
weeks	
Against a decision of a Centre Court to the COE	4 weeks
Against a decision of the Court of the Scottish ACU to the COE	4 weeks
Against a decision of a Sport Committee to the POA	4 weeks
2. The time limit shall be taken from the time or date of receipt of the decision appealed against.
3. In all cases the appeal bodies must pronounce a decision.

10.04.15 Effect of an Appeal

1. On request of the appellant, the COE may decide a stay of the decision of the Stewards of the Meeting.
2. On request of the appellant the FTA may decide a stay of the decision of the COE.

10.05 procedure Before all the Disciplinary and Arbitration Bodies

10.05.1 Right to a Hearing

1. Save for articles 9.07 and 10.03.1.3, it shall be the unquestionable right of any person or body charged with any offence under the National Sporting Code, its Appendices or the Rules of the ACU to defend themselves either in person or by proxy. Any party convened before a disciplinary or arbitration body has the right to be represented by one defence counsel of its own choice and at its own expense. Adequate notice of this intention must be given to the ACU in order that this may be notified to all other parties in the case. Failure to do so may result in the disciplinary or arbitration body upholding an objection to such representation. If any of the parties duly convened do not appear, judgement can be rendered by default. The discipline or

arbitration bodies may propose that the hearing take place by means of a telephone conference call, or through any other means of communication, using a telephone or other electronic device. Such a method of conducting a hearing shall only take place with the consent of all parties involved.

10.05.2 The Hearing

1. The hearing shall be open unless the disciplinary or arbitration body itself decides otherwise in exceptional circumstances.
2. The appellant must be present or duly represented, failing which, the appeal will not be admissible and the costs shall be borne by the appellant.
3. Once the Chairman has opened the proceedings, he will invite the parties involved to state their respective cases without the witnesses being present.
4. After statements of the parties concerned, the disciplinary or arbitration body shall hear the various witnesses and experts in order to complete the evidence. The parties involved in the case shall have the right to question all witnesses and experts on their evidence.
5. Any member of the disciplinary or arbitration body may, at any time during the hearing and with the Chairman's approval, question any of the parties, witnesses and experts involved.

10.05.3 Witnesses and Experts

1. Each party is responsible for the convening and appearance of its own witnesses, as well as their expenses unless the Court decides otherwise.
2. The disciplinary or arbitration body has no authority to oblige the witnesses to swear on oath, therefore testimony shall be given freely. The witnesses may only testify to the facts they know and shall not be allowed to express an opinion unless the disciplinary or arbitration body should regard them as experts on a particular subject and should ask them to do so.
3. After having made their statements, the witnesses may not leave the Courtroom and shall not be allowed to speak to any other witness who has still to give evidence.
4. The Court may summon experts.

10.05.4 Judgement

1. Decisions of all disciplinary or arbitration bodies will be reached in camera by a simple majority of votes. All members will have equal voting rights which must be exercised when a decision is required. Abstention is not permitted.
2. Each member of the disciplinary or arbitration body binds himself to keep all deliberations secret.

10.05.5 Notification of Judgements

1. The decision of the Clerk of the Course and the Stewards of the Meeting must be notified in writing directly after the hearing. All judgements of the COE the POA and the FTA must be notified in writing by Special Delivery letter to inform all the parties concerned.

10.05.6 Publication of Judgements

1. The disciplinary or arbitration body adjudicating a Protest or an Appeal has the right to publish or have its judgements published and to quote the names of all parties concerned. The persons or bodies quoted in these statements have no action against the ACU, nor against any person having published the statement. Furthermore, final decisions will be published in the ACU Magazine and/or the ACU website unless the Court itself decides otherwise.

10.06 Costs of procedure

1. The costs of a disciplinary or arbitration decision will be assessed by the General Secretary and will be awarded against the losing party unless the Court decides otherwise. In cases involving

Voluntary Officials the Costs may be awarded against the body which appointed the Official concerned at the discretion of the Court.

10.06.1 Payment of Fines and Costs

1. If a penalty is definitive and either the fine and/or the costs are not paid within 30 days of notification of the decision, the person or body affected by the decision shall be automatically suspended from participation in all ACU activities until such time as full payment is received.

10.07 Reciprocity of penalties

1. The ACU will withdraw the Licence of any person who is subject to a penalty of suspension or disqualification by the MCRCB or an FMN.

10.08 Law of Mercy

1. The Board of Directors of the ACU after consultation with the Chairman of the disciplinary body concerned or upon a proposal from the latter may recommend to the National Council of the ACU that the penalty of a person having exhausted all the appeal procedures be mitigated or completely quashed.

10.09 Arbitration Clause

1. Final decisions handed down by the jurisdictional organs of the ACU shall not be subject to appeal in the ordinary courts. Such decisions must be referred to the Sports Resolutions (UK) within the time limit for appeal as laid down in Article 10.04.7, which shall have exclusive authority to impose a definitive settlement in accordance with the Code of Arbitration applicable to sport.

CHAPTER 11 OFFENCES AND PENALTIES

11.01 Breach of Rules

1. Any of the following offences, in addition to other offences specifically referred to previously or hereafter, shall be deemed to be a breach of this Code and as such will be dealt with under Article 10.03 by the appropriate Body who may impose penalties as necessary:
 1. bribery, or attempt, directly or indirectly, to bribe any person having official duties in relation to a competition or the acceptance of or offer to accept a bribe by such Official or Employee,
 2. any attempt to influence improperly any Official in the course of their duties,
 3. any action having as its object the entry or participation in a competition of a person or motorcycle known to be ineligible therefore,
 4. any fraudulent act or proceeding in connection with a competition or of the sport of motorcycling generally.
 5. competing for, accepting or offering to accept, or advertising an award, in the nature of a title or Championship, in respect of a motorcycle competition, unless such award is recognised by the ACU Headquarters,
 6. any proceeding or act prejudicial to the interests of, any part or body of the ACU, or of the sport of motorcycling generally,
 7. any act which is of a violent, threatening or abusive nature to any Official, Rider or Passenger or any other person. For the purpose of this article, a prejudicial act shall be deemed to include (but not be limited to) the non-payment of fines, affiliation fees, permit fees, licence fees and insurance premiums. For the purpose of this article, the parent or legal guardian of a Rider or Passenger, or any member of his entourage, is deemed to bear mutual responsibility with that Rider or Passenger.
 8. The use of Social Media to propagate foul, abusive or offensive language, profane activity or fraudulent comments against any Rider, Official or member of the ACU (including its affiliated

Centres/Clubs/Promoters) or deemed to bring the ACU into disrepute by any accessible Social Media outlet (e.g. Facebook, Twitter, Blogs, Texts, Webshots, Instagrams, Public Forums) or any other Social Network sites is not permitted. The Entrant and/or Rider/passenger shall be responsible for the acts of his riders/mechanics, passengers or any member of his entourage. A parent or legal guardian of a rider or passenger is deemed to bear mutual responsibility with that competitor.

11.02 Re-Run

1. No judicial authority shall have the power in its judgement on a protest or appeal to order either a part or the whole of a competition which has been completed to be run again.

11.03 Allocation of proceeds from Fines etc.

1. The proceeds from all fines, forfeited protest fees and appeal fees, shall be remitted to ACU Head Office, which will pay them into the ACU Benevolent Fund.
2. All protests to the Clerk of the Course must be made in accordance with article 10.4.3 of the National Sporting Code (NSC) and be accompanied with the correct fee. The fee is returnable if the protest is justified or forfeited if the Disciplinary Body considers the protest to be groundless, or if it is withdrawn without a hearing. The same applies with regard an Appeal to the Stewards of the Meeting. Notwithstanding the above, there are circumstances that may dictate the protest/appeal fees be returned to the appellant at the discretion of the Clerk of the Course/Stewards of the Meeting.

11.04 quashing a Competition

1. The authority granting the permit may declare any competition null and void, subject to the right of appeal as provided in these Rules.

11.05 Notices

1. Any communications required under the Rules to be made to the ACU Headquarters shall be addressed to the registered office of the ACU, ACU House, Wood Street, Rugby, Warwickshire CV21 2YX or to such other address as may be duly notified from time to time.
 2. Any communications required under these Rules to be sent to an entrant or rider shall be sent to the address on his entry form or, if he is the holder of a licence issue by the ACU, to the address on the licence. Any communications to be sent to an Organiser shall be sent to the address on the relevant Supplementary Regulations.
 3. Any communications to be sent to an appellant under these Rules shall be sent to the address upon the notice of appeal.
- Any communications so sent by special delivery shall be deemed to have reached the addressee by normal delivery of post.

AppENDIX A DISCIPLINARY DECISIONS & PROTEST & APPEAL PROCEDURE

DISCIPLINARY PROCEDURE

pROTEST & AppEAL pROCEDURE

DISCIPLINARY DECISION
(By the Clerk of the Course issued in writing)

Decision Issued in Writing
protest permitted

RIGHT OF pROTEST (To the Clerk of the Course)
Any ACU licensed Rider, Passenger Entrant or Official affected by a decision taken during a meeting held under an ACU Permit has the right to protest against that decision. No protest can be lodged against a statement of fact pronounced by the Clerk of the Course or any other Executive Official. **pROTEST FEES**

International Competition	£150.00
National/Restricted/Closed Competition	£100.00

pROCEDURE AND TIME LIMIT FOR pROTESTS
All protests must be submitted in writing and signed by the person directly concerned. Protests must refer to a single subject only and be presented within 30 minutes at the latest of the publication of the results unless otherwise provided in the Appendices of the ACU National Sporting Code. During a meeting, protests must be handed to the Clerk of the Course or Secretary of the Meeting accompanied by the correct protest fee. Any Protest against the eligibility of a rider, passenger, team or a motorcycle entered must be made before the start of the official practice unless otherwise defined in the relevant Appendices and Regulations.

Clerk of the Course (COC)

Decision
Appeal Permitted

pROCEDURE AND TME LIMIT FOR AppEALS (To the Steward(s))
All Appeals must be submitted in writing and signed by the person directly concerned. Appeals may be made against any decision previously made by Clerk of the Course. Appeals to the Steward(s) must be made within 30 minutes unless otherwise provided in the relevant Appendices of the ACU National Sporting Code or Regulations.

AppEAL FEE

To the Stewards of the Meeting	£100.0
--------------------------------	--------

TIME LIMITS FOR THE LODGING OF AppEALS

Against a decision of the Clerk of the Course to The Steward(s) of the Meeting	30 minutes
Against a decision of the Steward(s) of the Meeting to the ACU Court of Enquiry (COE)	5 minutes
Against a decision of the COE to the Final Tribunal of Appeal	5 days

The time limit shall be taken from the time or date of receipt of the decision appealed against.

Decision of FTA
No further appeal

ACU Final Tribunal of Appeal (FTA)

Decision
Appeal permitted to Final Tribunal of Appeal (FTA)
Appeal Fee £5,000

ACU Court of Enquiry (COE) Rugby

Decision
Appeal permitted to ACU Court of Enquiry at Rugby (COE)
Appeal Fee £300

Local Centre Court (LCC)

Decision
Appeal permitted to the Permit Issuing Authority (PIA)
Appeal Fee £300 if pIA is ACU Hq Rugby
Appeal Fee £150 where PIA is a Steward(s) of the Meeting



AppENDIX B PROTEST AND APPEAL PROCEDURE – TRIALS AND ENDURO

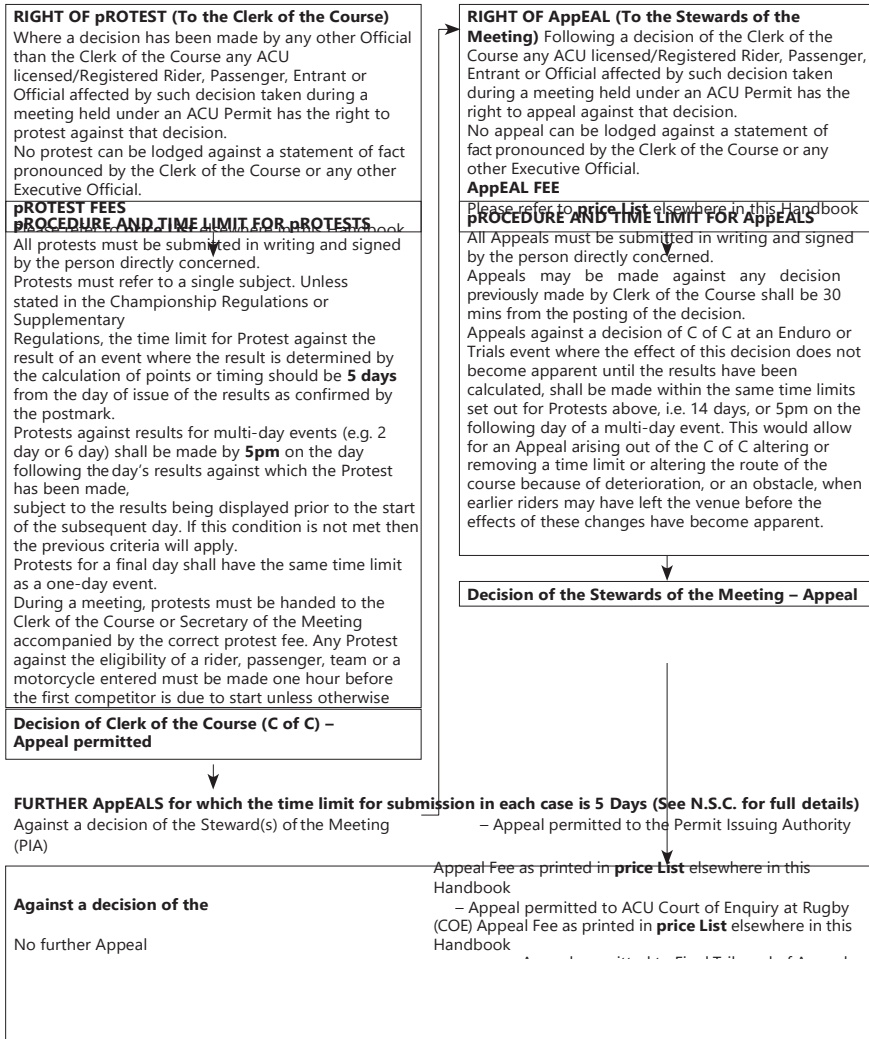

APPENDIX C INSURANCE

(Refer to current ACU Handbook)

1. General

1. The ACU shall effect policies of Insurance as specified in this Appendix, through such Brokers or Insurers as they shall from time to time appoint.
2. The requirements of this Appendix shall be subject to the market availability of such insurance, both in detail and in general.
3. The requirements laid down in this Appendix are general requirements and shall not be deemed to form part of any contract between the ACU and its Centres, Affiliated Clubs, Approved Bodies, Officials or Licence Holders nor between the ACU and its appointed Brokers or Insurers in specific cases.
4. Nothing contained within this Appendix shall prohibit any Centre, Affiliated Club, Approved Body or Official from seeking direct contact with the Appointed Brokers or Insurers, for the purpose of obtaining advice, or clarification of policies provided that the Company Secretary is kept informed by copy correspondence.

2. Legal Liability

1. The policy or policies shall provide indemnity in respect of accidental death of or bodily injury to or damage to the property of third parties.
2. The policies shall indemnify the ACU, Local Centres, Affiliated Clubs, Approved Bodies (as defined by NSC Art. 3.05), Officials of these Bodies and Officials and Sponsors of events. Details, including the limit of indemnity for any one accident to be included in the annual ACU Handbook.
3. The owner of land used for the holding in part or in all of any event subject to the Code shall be included under the policies as an insured person.
4. The policies shall be capable of extension to indemnify the promoter in respect of liabilities for accidental injury or damage to property, entered into under contract with any owner of land. Subject to such contract being submitted in advance to insurers for approval.
5. In respect of any event or part of an event held off the public highway, the policies shall in addition indemnify Competitors, Entrants or Sponsors of Competitors.
6. The policies shall include the liability of one Insured Person or Body, except that the liability of the one Rider, Passenger, Entrant or Sponsor, to another Rider, Passenger, Entrant or Sponsor in respect of their participation in the same event, shall not be covered.
7. In respect of any event or part of an event held in circumstances to which the provision of the Road Traffic Act, or similar legislation governing the use of motor vehicles apply it shall be the responsibility of the Competitor to effect insurance to comply with such legislation.
8. The policies shall include cover in respect of the setting up or dismantling of courses for a specific event, although taking place before or after the date of the event.
9. In addition to any exclusion specifically referred to in this Appendix or to any standard prevailing market exclusions for this Class of Insurance, the policies shall not apply to nor include:
 1. Events not subject to the Jurisdiction of this Code or the FIM Code.
 2. Use of any motor vehicle in circumstances requiring insurance under the Road Traffic Act or similar legislation.
 3. Any risk arising from the movement of aircraft.
 4. Subject to Appendix 'C' Art. 2.4, any liability for Property used in connection with an event or in the Promoters/Organisers custody or control.
10. The policies shall not be required to provide indemnity to any person or body who is in breach of this Code or any other requirements or regulation of the ACU.
11. All Riders or Passengers in an event shall sign a declaration of the prescribed type as shown in the current ACU Handbook or as varied in accordance with the Insurers' requirements.

APPENDIX D MOTORCYCLES AND ACCESSORIES

1. The Standing Regulations for each discipline contain detailed rules for each type and class of competition and must be read in conjunction with this Appendix. Unless stated otherwise in Supplementary Regulations, all ACU Championships and Competitions are for and between vehicles of Category 1 propelled by an internal combustion engine.

1. Motorcycles

The term motorcycles covers all vehicles having in principle less than four wheels, propelled by an engine and designed essentially for the carriage of one or more persons of which one is the rider of the vehicle. The wheels must support the vehicle at all times and remain in contact with the ground other than when influenced by irregular terrain or force majeure.

2. quad Machines

(Category II Group G)

2. Freedom of Construction

1. Provided a vehicle conforms to the requirements of this appendix and any discipline regulations and the Supplementary Regulations as well as to any specific Conditions that may be required for certain competitions, no restriction is placed on the make, construction or type of motorcycle used in competition. All vehicles must be entirely controlled by the rider. Any form of automatic control of the degree of differential movement between the wheels of a machine is prohibited. Where a passenger is carried stability may be improved by passenger movement.

3. Categories and Groups of Motorcycles

1. Motorcycles are divided into categories:

CATEGORY I

Motorcycles propelled by the action of one wheel in contact with the ground.

CATEGORY II

Special vehicles propelled by the action of one or more wheels in contact with the ground but which are not covered by the group conditions for Category I.

CATEGORY III

Electric Vehicles.

Electric propulsion motorcycles are Category III. Vehicles with two or three wheels having traction on one or more wheels, driven by a motor (or motors) operated by means of electricity only. Wheels must normally be in contact with the ground.

CATEGORY IV

Special vehicles not propelled by wheels in contact with the ground. An enclosing shell or body may be fitted with fixed aerodynamic devices to aid directional stability or increase 'down force' only.

THESE CATEGORIES ARE DIVIDED INTO GROUPS:

CATEGORY I

Group A1 Two wheeled vehicles making only one track on the ground.

Group A2 Motorcycles with special characteristics commonly known as 'scooters' and defined in scooter regulations.

Group A3 Motorcycles with special characteristics commonly known as 'mopeds' and defined in moped regulations.

Group B1 Vehicles with three wheels making two tracks on the ground, consisting of a motorcycle making one track and a sidecar for a passenger making the other track.

Group B2 Vehicles comprising motorcycle and sidecar making three tracks on the ground,

two of the tracks being made by the front and rear motorcycle wheels whose centre lines in the direction of forward travel are displaced by a maximum of 75mm.

Group B3 Vehicles making three tracks on the ground forming a complete and integral unit and having accommodation for driver and passenger, commonly known as 'cycle cars' and defined in cyclear standing regulations.

CATEGORY II

Group C Special two wheeled motorcycles. **Group D** Special three wheeled motorcycles. **Group E** Snowmobiles.

Group F Sprinters and Drag Racers. **Group G** Quad Machines

CATEGORY III

Group J Electric vehicles

CATEGORY IV

Group Y1 Special two wheeled non wheel-driven motorcycles.

An additional wheel or wheels may be fitted to aid low speed stability but must be discarded or retracted during competition or record attempt. The overall width of the machine must not exceed 800mm.

Group Z2 Special three wheeled non wheel-driven vehicles.

4. Classes

1. Groups are again separated into classes according to engine size (capacity) as detailed below. These classes must be observed for all types of competition except within Categories III and IV or except with special permission of the ACU. In exceptional circumstances and with the approval of the Stewards of the Meeting organisers may amalgamate classes should the size and type of entry appear to warrant such action.

CLASSES – CATEGORY I

Group A1 Class	Minimum Engine Capacity over CC	Maximum Engine Capacity CC
50	—	50
80	50	80
100	80	100
125	100	125
175	125	175
250	175	250
350	250	350
500	350	500
750	500	750
1000	750	1000
1300	1000	1300
Group A3		
—	—	50

Groups B1, B2 and B3, same as Groups A1 over 175cc.

CLASSES – CATEGORY II

Groups C & D

Regulations governing the classes in these groups to be issued as each case is presented.

Group E

Snowmobiles. As International Regulations (FIM)

Group F

Sprint and Drag Machines. Sprint and Drag Racing machines up to 1300cc as groups A1 and A2. Over 1300cc:

Class 2000	Over 1300cc	up to 2000cc
Class 3000	Over 2000cc	up to 3000cc
Class 3500	Over 2000cc	up to 3500cc

Group G

Quad Machines.

Four wheeled balloon tyred vehicles having a wheel at each diagonal extremity, consisting of a complete integral unit having accommodation for a driver only sitting astride, steered by a handlebar connected to the front wheels and driven by rear wheels only. Classes as Category I Group A1.

CLASSES – CATEGORY III

Group J – A1

Two wheel vehicles leaving only one track on the ground.

These motorcycles must be driven forward by electric motors equipped with energy storage systems of the electro-chemical type. Fuel cells are forbidden. Maximum weight 300kg.

Group J – B2

Three wheel vehicles leaving two or three tracks on the ground, forming an integral unit. These motorcycles must be driven forward by electric motors.

Class A: with electro-chemical energy storage systems. Fuel cells are forbidden. Maximum weights (in running order, without driver):

A1) 250kg A2) 500kg A3) 750kg.

Class B: solar cycle-cars, powered by electric motors driven by energy from photo-voltaic panels, with the possibility to use storage batteries.

Maximum weight of the batteries (inclusive of their container): 60kg. The batteries must be easy to take out for weighing.

Minimum panel surface: 4.5sq m.

All alternative propulsion systems are forbidden (human, internal or external combustion auxiliary engines, wind-engines).

Vehicle kinetic energy can be recuperated to perform battery re-charge.

5. Measurement of Engines

1. The size of an engine is the sum of the capacities of each cylinder of that engine. The capacity of each engine cylinder is calculated by the geometrical formula for the volume of a cylinder; the diameter is represented by the cylinder bore, and the height by the distance moved by the piston from its highest to lowest position within the cylinder (stroke).

$$\text{Capacity} = \frac{D^2 \times 3.1416 \times C}{4}$$

Where D = Bore and C = Stroke

2. When measuring a tolerance of 1/10mm is permitted in the bore. If with this tolerance the capacity limit is exceeded for the class in question, a further measurement must be taken with the engine cold to 1/100mm limits. Other types of engine to which this rule is not appropriate may be used in competition, engine size should be determined by reference to the Technical Panel.

6. Carburettors or other Air Input Control Instruments

1. Except as in (b) below size is defined as that nominal diameter obtained from the geometrical formula:

$$\text{Size} = \sqrt{\frac{4A}{3.141}} \text{ to the nearest 1.00mm.}$$

2. Where A is the minimum cross sectional area in square mm (mm²) of the induction tract within the carburettor body (mixture or control devices excepted). In Competitions where Carburettor(s) or Other Air Input Instruments are Homologated or a maximum choke size is specified.

The following induction tract conditions must exist where the instrument joins to manifold or engine and immediately adjacent thereto, the conditions may be satisfied by either the instrument itself, the manifold or engine where it attaches or an element of durable material inserted between.

1. All induced air must pass through this induction tract.
2. Induction tract at the interface to be circular in shape, maximum diameter no more than homologated size, or that maximum specified in any relevant regulations.
3. Induction tract to be of constant diameter over a minimum distance equal to 75% of homologated carburettor size or specified maximum choke size.

7. Identification Numbers

1. During a competition each motorcycle shall carry, prominently displayed, such numbers or marks as may be stipulated in the appropriate Standing or Supplementary Regulations.

8. Examination of Machines

1. Every motorcycle shall be examined before the start of a competition or before the start of official practice to ensure compliance with the technical specifications.
2. The rider of any motorcycle which starts in a competition shall, if required, submit the motorcycle for final examination, and any motorcycle may be retained by the organisers for such a period as may reasonably be necessary for its examination and/or measurement to ensure compliance with technical rules.

9. Measurement of Machines

1. The engine or any other controlled part may be verified on the instructions of the Clerk of the Course or to determine a protest.
2. The Clerk of the Course, at his own discretion, may decide if the measurement may take place other than at the event. In such a case, the part or the engine shall be sealed and measurement shall take place as soon as possible. Failure to submit to verification will entail disqualification. Any necessary dismantling shall be carried out by the entrant, or under his instruction. The entrant shall be responsible for any costs involved unless measurement of specific machines is required by the Supplementary Regulations in which case all fees and maximum allowable part costs (gaskets etc) shall be specified in those regulations and be the responsibility of the organiser unless an infringement of regulations is proved. A protest, the organisers of the meeting shall be responsible for the payment of the fees and costs of the official measurer.
 1. If measurement takes place to determine a protest, the party against whom the decision is made shall be responsible for payment of the fees and costs including those of the official measurer, and for the reinstatement of the machine. (see price list and individual Discipline Regulations)
 2. If measured in accordance with a directive issued by a Main Committee of the ACU, the fees and costs including those of the official measurer shall be borne by the ACU, otherwise than in relation to a Protest or Appeal.

10. Advertising

1. Advertising may be displayed on a vehicle and on the rider's and or passenger's clothing and helmet in any competition, subject to the following conditions:
 1. No advertisement shall be displayed within 50mm of any number plate or number plate panel.

2. The name of the vehicle and/or sidecar or clothing manufacturer and/or the name of the rider will not be regarded as advertising.
3. Notwithstanding the above conditions, the organisers of any competition may, at their sole discretion, prohibit the display of any advertisement on a vehicle or on the clothing or helmet of any rider or passenger.
4. Where advertising, or any particular advertisement, is prohibited all drivers must be notified at least seven days before the date of the meeting.
5. The ACU may prohibit the display of any advertisement which it deems to be offensive, or not in the best interests of the sport.

11. Brakes

1. All motorcycles used in disciplines requiring brakes must be equipped with efficient systems operating on and concentrically with the wheel. The number of braked wheels and other special requirements will be found in the discipline Standing Regulations.

12. Dangerous Construction

1. The Clerk of the Course may, or on the advice of the Chief Scrutineer/Machine Examiner, disqualify any vehicle, or equipment, the construction or condition of which is deemed to be dangerous.

13. positions of Rider and passenger

1. During a race, riders should adopt a position with their feet on the footrests. If a rider adopts any other position and this is deemed to be dangerous by the Clerk of the Course he must be disqualified. During a race or competition, the passenger, if any, must be effectively and continuously carried on the vehicle. The passenger however, may be dismounted when the vehicle is stationary, dismounted for starting, or may move from the place provided to maintain stability.

14. Throttle (Accelerator) Controls

1. For all types of vehicle, throttle controls must be self closing when not held by the hand or operated by the foot.

15. Chain Guards

1. If the primary transmission is exposed, it must be fitted with a guard as a safety measure. The guard must be conceived in such a manner that under no circumstances can the rider or passenger come into accidental contact with the transmission parts. It must be designed to protect against finger injury. On "Off-road" and "Sprint" machines, a guard must be fitted to the counter shaft (gearbox) sprocket. Individual disciplines may require additional protection for rider and passenger, any additional protection must comply with FIM rules and will appear in the discipline standing regulations.

16. Exhaust Sound Control

1. The ACU will stipulate and may from time to time vary maximum sound levels permitted for machines used in the various sporting disciplines, also the conditions and method of sound testing to be used. Engine stroke in millimetres must be permanently and prominently displayed on the crankcase for use in sound control calculations.
2. The Clerk of the Course may, at his own discretion or on the advice of a Sound Control Inspector, exclude any vehicle deemed to be excessively noisy. Other penalties may be imposed by the relevant National Sporting Committee.

17. General

1. It is the responsibility of the rider to ensure a machine and equipment used in competition is mechanically and structurally in a safe condition and fit for the intended purpose. When due to the nature of the competition the machine is ridden on the Public Highway, it is also the responsibility of the rider to ensure compliance with all Road Traffic Act(s) requirements.

section

**RULES OF THE
UNION**

Rules of the Union

A THE ACU NATIONAL COUNCIL	481
B THE GROUPS OF THE AUTO-CYCLE UNION LIMITED	483
C SPORT COMMITTEES AND ADVISORY PANELS	485
D SUB-COMMITTEES	494
E BOARD OF DIRECTORS	494
F INTERESTS	496
G FINANCES	496
H SUBSCRIPTIONS	497
I CESSATION OF MEMBERSHIP	497
J ACU LTD MOTORCYCLING FORUM	498
K SPORT FORUMS	498
L AGE RESTRICTIONS	498
M DEFINITIONS	498
THE AUTO-CYCLE UNION (ACU) LIMITED	
MODEL LOCAL CENTRE BYE-LAWS	498

THE AUTO-CYCLE UNION (ACU) LIMITED RULES AND BYE-LAWS JANUARY 2020

Made by the Board of the ACU Ltd pursuant to Article 51 of the Articles of Association

A THE ACU NATIONAL COUNCIL

1. The National Council is the representative body of Centres of the ACU Ltd, SACU and the Non-Territorial Board. The Composition shall be: one voting delegate from each Centre and SACU and two voting delegates from the Non-Territorial Board. A non-voting understudy may be appointed for each of the above votes. The Board of Directors shall ordinarily attend the National Council but have no voting rights. Sport Committee Chairmen may exceptionally be represented by their Deputy Chairman.
2. The National Council will form part of the consultation process of the policy of the ACU Ltd.

3. THE AUTHORITY OF THE ACU NATIONAL COUNCIL

1. The Board of Directors shall consult the National Council prior to amending, rescinding or adding to the Rules. The National Council in conjunction with the Board of Directors shall be the authority as to the interpretation of these Rules. Any voting at National Council shall require a majority of two thirds of those present and voting except where otherwise provided for in these Rules and the Articles of Association of the Auto-Cycle Union Limited.
2. Rule changes shall come into effect immediately unless otherwise stated, with such changes occurring as necessary throughout the year.
3. Have the authority to make such standing orders for the conduct of its business and such regulations or bye-laws for the encouragement and control of the local Centres and the Non-Territorial Board as it may think fit.

4. MEMBERSHIP OF THE ACU NATIONAL COUNCIL

1. The Chairman of the Board of Directors shall also be the Chairman of the National Council and such individual shall also be known as 'Chairman of the ACU' or 'Chairman of the ACU Ltd' or 'Chairman of the Union'.
2. The Board of each local Centre/SACU shall appoint one delegate, the Non-Territorial Board shall appoint two delegates of the ACU National Council who unless otherwise made ineligible shall remain in office for a minimum period of one year and a maximum period of three years. The individuals shall be eligible for re-appointment subject to Rule 3.
3. To be eligible for appointment as a delegate of the ACU National Council an individual shall be an individual subscribed member of an ACU Affiliated Club and remain so throughout office.
4. Any delegate of the ACU National Council who is not able to attend any meeting of the Council may be represented by a formally nominated alternate.
5. Unless attending in another capacity the Chairmen of the Advisory Panels may attend ACU National Council by invitation. They shall have no voting rights.
6. Any delegate of the ACU National Council may be suspended for a specified period, or be disqualified from being a delegate to the ACU National Council by resolution of the ACU National Council of which due notice has been given and for which a two-thirds majority is obtained. Any delegate so suspended or disqualified shall thereby forfeit his or her position as a delegate to the ACU National Council (and of any Committee or Sub-Committee of which he or she is a member and, where specifically agreed by the ACU National Council, all rights and privileges of affiliated membership for the period of the suspension, or in the case of disqualification, permanently. In the case of suspension or disqualification the appointing local Centre/SACU/NTB will be invited to make an interim appointment to hold office for the remainder of the term of the removed delegate.

5. NOTICE OF MEETINGS

1. Notice of motion for debate at any meeting of the ACU National Council may be proposed, on behalf of his or her appointing body, by any delegate to the ACU National Council, or by the Board of Directors, or any Sport Committee or Advisory Panel. Such notices of motion must be received by the General Secretary not later than 21 clear days prior to the date of the meeting.
2. Due and adequate notice (with Agenda) with all meetings of the ACU National Council or Committees stating the date, time and place shall be circulated by the General Secretary of ACU Ltd to all persons entitled to such notice. Generally seven clear days notice will be deemed to be adequate for meetings of Committees but fourteen clear days notice of meetings of the ACU National Council should be given subject to the Company's Articles of Association article 9.

6. ELECTION PROCEDURE – NATIONAL COUNCIL (OFF ROAD ACTIVITY)

1. Independent tellers shall be appointed by the National Council to supervise the running of the elections and to count the ballot papers.
2. Voting shall be by identified ballot paper, with ballot papers identifying the voting member by the Centre/SACU/NTB number that has appointed them. All votes will be recorded in the minutes of the meeting identifying the Centre SACU/NTB and the way in which their vote was cast.
3. Ballot papers shall only be deemed valid if they contain the required number of votes, be they in favour of candidate(s) or abstention(s).
4. Abstentions will form part of the calculation and count towards the total votes cast. For each ballot, the member will cast a total of votes equivalent to the number of vacancies to be filled in that round of the ballot. The member when voting, may express a vote in favour of a candidate or candidates or express a vote or votes of abstention. The number of votes cast per ballot shall equal the number of vacancies. Ballot papers not having the corresponding number of votes shall be deemed spoilt and not count towards the calculation of the vote for that round.
5. To be elected, a candidate needs an absolute majority of the votes cast (50% of the votes cast + 1, rounded up to the next highest whole number). If there are less vacancies to be filled than there are elected candidates, the posts shall be filled by those candidates having received the highest number of votes.
6. If all the vacancies have not been filled after the first round of voting, the following procedure shall apply:
 - If the number of remaining candidates is higher than the number of vacant position(s) after the first round, the number of candidates allowed to participate in the second round shall be selected according to the highest number of votes they have obtained and by applying the following formula: number of vacant position(s) plus one/or more in the case of a tie).
 - If the number of candidates is equal or less than the vacant positions after the first round, all candidates shall take part in the second round.
7. In both cases, only the candidate(s) who has/have obtained the absolute majority (50% of the votes cast + 1 vote, rounded up to the highest high number) shall be elected. If there are less vacancies to be filled than there are elected candidates, the posts shall be filled by those candidates having received the highest number of votes.
8. There shall be no third round of voting and the remaining position(s) shall remain vacant.
9. Any position which fell vacant before a period of office has ended or which remained vacant from a previous election shall be filled at the following meeting of the National Council. A position prematurely vacated shall be filled for the remainder of the period of office.
10. If posts with different periods of office are to be filled, the allocation of posts shall be in descending order of votes received.

7. ELECTION PROCEDURE – (ROAD RACE COMMITTEE)

1. The election procedure for candidates nominated for the Road Race Committee can be found at Section C.3.1.5 to C.3.1.9.

B THE GROUPS OF THE AUTO-CYCLE UNION LIMITED

The following rules govern the formation and running of the Local Centres.

1. There shall be Local Centres, comprising all Affiliated Local Motorcycle Clubs (i.e. Clubs that have signed an Affiliation Agreement) in the British Isles excluding Ireland, subject to any agreements in force from time to time.
2. The Board shall define the area of each territorial district, which shall be called a "Local Centre", and which shall be constituted as set out in this Rule.
3. Each Local Centre must adopt and abide by Local Centre Bye-Laws drafted in accordance with the model Local Centre Bye-Laws which are a supplement to these Rules and Bye-laws.
The model Bye-Laws may be amended to suit Local Centre needs, but as amended may not contravene nor conflict with any part of these Rules and Bye-laws unless formally presented to, and agreed by, the Board.
4. Any Local Motorcycle Club, Association, Institution or other local body or section of such local body connected with the sporting, recreational or leisure activity of motorcycling shall, through the appropriate Local Centre of the ACU Ltd, be eligible for affiliation to the ACU Ltd under a standard form of agreement (as amended from time to time).
5. An application by a Local Motorcycle Club for affiliation to the ACU Ltd shall be submitted to the Board for approval, and shall indicate whether or not it is supported by the Local Centre within which the Headquarters of the Club is situated (together with reasons if not). If not so supported, the application shall be referred by the Board to the National Council at the next general meeting of the ACU Ltd, and the National Council shall determine the application by ordinary resolution.
6. A change of name of an Affiliated Motorcycle Club shall be subject to approval as in paragraph (5) above.
7. Clubs, the headquarters of which are within 10 miles of the boundary of a Local Centre, shall have the option of affiliating to either the Centre in which their headquarters are situated, or an adjacent Local Centre.
8. No Affiliated Local Motorcycle Club shall be entitled to transfer its affiliation from one Centre to another by reason of a change of position of its headquarters. Any Affiliated Local Motorcycle Club so situated and having exercised such option shall not withdraw its affiliation from a Local Centre without having made written application to the ACU Ltd for permission to transfer its affiliation and obtained consent thereto. All applications for the transfer of an Affiliated Local Motorcycle Club from one Local Centre to another shall be approved by ordinary resolution of the National Council in general meeting.
9. A Local Centre may form Groups, for the encouragement of local competitions. An Affiliated Local Motorcycle Club may belong to more than one Group, provided that the Groups concerned are not formed for the same purpose.
10. The objectives of Local Centres shall be to:
 1. Foster and encourage the sport of motorcycling within its district, and carry out such administration as may be required by ACU Ltd from time to time;
 2. Safeguard the rights and privileges of members of Affiliated Local Motorcycle Clubs within its district by watching the action of bodies whose policies may affect the interests of the sport, by representing the ACU Ltd at any local conference or meeting in which motorcyclists are interested, and by reporting to the ACU Ltd any matter not conducive to the welfare of the sport and pastime of motorcycling in general. Such representation shall be delivered by the Chairman and/or Secretary, or their nominee.
 3. Assist Affiliated Local Clubs in their district in the holding of competitions and other events,

to promote inter-club and inter-centre competitions and to co-operate with the ACU Ltd in the administration of the National Sporting Code at any competition held within its district.

LOCAL CENTRE MODEL BYE-LAWS

11. Subject to article 10 of the Local Centre Model Bye-Laws a Local Centre shall function in accordance with the Local Centre Model Bye-Laws as annexed to these Rules and Bye-laws. A Local Centre may adopt such additional Local Bye-Laws as may be considered necessary. Such additional Bye-Laws shall be submitted to the Board, and the Board shall have the authority to veto any decision or proposed action of a Local Centre which is considered by the Board to be detrimental to the interests of the ACU Ltd or the sport and recreation of motorcycling, and nothing shall be done by a Local Centre which is contrary to the Rules and Bye-laws of the ACU Ltd at the time in force.

NON-TERRITORIAL CLUBS

12. A Non-Territorial Club is a Club, Association, Institution or other body or section of such body connected with sporting, recreational and leisure activities having objectives, activities and membership which does not restrict it to Local Centre membership, and having headquarters in the British Isles excluding Ireland, which, subject to approval of the Board, shall be eligible for direct affiliation to ACU Ltd.
13. Each Non-Territorial Club shall be represented at the Non-Territorial Board as follows: one delegate for club membership in excess of one hundred members; two delegates for clubs with over five hundred members. Such delegates shall be appointed annually by their Club.

ACU REGIONS

14. ACU Regions may, as determined by the Board, comprise groupings of Local Centres, and parts of Local Centres and Non-Territorial Clubs reflecting the structure of the UK, English, Welsh and Scottish Sports Councils, or such successors carrying on the functions of those agencies from time to time.
15. Non-Territorial Clubs, which have activities within any ACU region, shall have the right to be consulted, to attend and speak at meetings within that region, without voting authority.
16. Non-Territorial Clubs shall together comprise the ACU Non-Territorial Regional Board.

RECOGNISED ASSOCIATIONS

17. A Recognised Association shall be any organisation or body (not being an Affiliated Club) which on application and payment of an annual subscription shall be recognised by the Board as having an interest in motorcycle sport and recreation, and which is considered not to be in conflict with the interests of the ACU Ltd.
18. Recognised Associations shall be entitled to receive annual and periodical publications, to attend without voting authority and speak at the Non-Territorial Board, and to attend seminars and other meetings by invitation for which a fee may be charged.

AFFILIATED MEMBER

19. An Affiliated Member is an individual who is a fully paid up member of one or more Clubs affiliated to the ACU. Such an individual shall be eligible to take part as an official of the ACU or as a Competitor in any competition organised under this National Sporting Code provided he holds a current Competition Licence/Trials Registration, and meets any other eligibility requirement specified in the National Sporting code, its Appendices or Event Regulations. Competition Licence holders in all disciplines will be deemed eligible also to ride in Trials. Without prejudice to any other rights, Affiliated Membership may be refused or may be withdrawn at any time by the Board with the right of appeal to the National Council. All

Applications for Competition membership are subject to the approval of the Board of Directors of ACU.

ASSOCIATE MEMBERS

20. An individual who is not a member of an Affiliated Club and is not a competitor in any ACU Ltd competition for which a Competition Licence is required, nor acts as an Executive or administrative official at any ACU Ltd competition is eligible to participate in the ACU Ltd Member Benefits Scheme but shall not be eligible to play any part in the democratic structure of the ACU Ltd. Without prejudice to any other rights, Associate Membership may be refused, or may be withdrawn, at any time by the Board with a right of appeal to the National Council. See Rule I (2).

HONORARY MEMBERS OF THE UNION

21. Honorary Members of the Union shall be persons who have distinguished themselves in promoting the cause of motorcycling, or who have rendered conspicuous services to the ACU Ltd, and may include representatives of foreign motorcycling associations.
22. Nominations for Honorary Membership of the Union must be made in writing and may be made by Affiliated Local Motorcycle Clubs (endorsed by Local Centres) Local Centres/SACU and Non-Territorial Clubs not later than 31st August each year.
23. Honorary Membership of the Union shall be subject to confirmation by the National Council.
24. Subsequent to his appointment as an Honorary Member of the Union, notwithstanding that he may not be a Member, shall be entitled to attend all National Council meetings and speak when invited to do so by the Chairman. There shall be no right to vote.

C SPORT COMMITTEES AND ADVISORY PANELS

1. There shall be the following Sport Committees and Advisory Panels:
 1. Road Race Drag and Sprint
 2. Motocross
 3. Trials and Enduro
 4. Track Racing
 5. Technical Panel
 6. Sustainable Event Management Panel
 7. Medical Panel
 8. Panel of Adjudicators
 9. any other Sport Committee and/or Advisory Panels approved by the Board from time to time.The quorum of each Sport Committee and Service Panel shall be 50% of its membership from time to time.
2. Members of any Committee are eligible to stand for re-election subject to the provisions of Rule L. Except for the Committee Chairmen who becomes a Director by right, no other Director may be elected to a Sport Committee, nor any Committee Member become a Director.
3. Nominations for membership of a Sport Committee or the Board of Directors can only be accepted for one Sport Committee or the Board of Directors. Individuals wishing to be considered for election cannot be nominated for two or more Sport Committees or a Sport Committee and the Board of Directors in the same election year.

3 ROAD RACE DRAG & SPRINT COMMITTEE

1. **Terms of Reference.** The Road Race Drag & Sprint Committee shall be responsible for the regulation and development of Road Race, Drag & Sprint and shall consist of:
 1. Three persons elected by the Road Race Committee meeting in open session.
 1. One person to be elected each year to serve for three years from the 1st January following the election.

2. Nominations for membership of the Road Race Committee may be made by Affiliated Local Motorcycle Clubs (endorsed by Local Centres), Local Centres/SACU and Non-Territorial Clubs. These nominations must be completed and reach ACU Head Office not later than 31st August in each year, subject to the following provisions:

1. Nominations submitted by Affiliated Local Motorcycle Clubs must be endorsed only by either the Centre Chairman or Centre Secretary.
2. Nominations submitted by a Local Centre must be endorsed only by either the Centre Chairman or Centre Secretary.
3. Nominations submitted by a Non-Territorial Club must be endorsed only by either the Non-Territorial Board Chairman or Secretary.
4. Nominations submitted by a Recognised Promoter must be endorsed only by the NTB/a Centre Chairman or a Centre Secretary.
5. Nominations can be sent by post or email. If sent by post, the nomination should be marked 'Election Paperwork' and sent to ACU Head Office, ACU House, Wood Street, Rugby, Warks, CV21 2YX. If sent by email, the nomination should be emailed to neil@acu.org.uk and the same email copied to dw@acu.org.uk. An acknowledgement will be sent by return once the nomination has been received. Nominations must be sent in good time as to reach ACU Head Office by 31st August in each year. Any nominations received after this date will not be accepted.
6. The Board of Directors reserve the right to refuse a nomination for the Board if they have reason to believe the nomination would be detrimental to the ACU and/or motorcycle sport in general. Once the refusal of a candidate's nomination has been decided, the General Secretary will convene a meeting within 14 days between nominated members of the Board of Directors (a maximum of three) and a National Council Panel to explain the decision to refuse a candidate's nomination.
7. The National Council Panel will be selected by Ballot. Two Members of Staff not directly involved with the National Council or the election process would conduct the selection. The Centre(s) who had endorsed the nomination would not be eligible for this process. Five Centres will be selected and once done so, a letter of convocation to be distributed by the General Secretary to arrange said meeting.
8. Following the meeting between the nominated members of the Board of Directors/ National Council Panel, a person (from the National Council Panel) will be nominated to write to the Centre(s) who have endorsed the nomination outlining the reasons why a candidate's nomination has been refused.
9. The Centre(s) who have endorsed the candidate's nomination will then decide whether to withdraw the candidate's nomination or continue to support the nomination.
10. Should the Centre(s) decide to continue their support of the candidate's nomination, the candidate can appeal in writing accompanied with an Appeal Fee of £300.00 to the General Secretary within five days from the date of the meeting between the Board of Directors and the National Council Panel. The General Secretary will then convene a National Council Panel (five members), to hear the Appeal and if successful the nomination can be accepted for the next election process in that year, provided the nomination is submitted in accordance with the Rules of the Union. Members of the Board of Directors (a maximum of three) would also be invited to attend to give reasons for refusing the nomination in the first instance.
11. The National Council Panel will be selected by Ballot. Two Members of ACU Staff not directly involved with the National Council or the election process would conduct the selection. The Centre(s) who had endorsed the nomination would not be eligible for this process and also those Centre(s) involved in the process outlined at paras 7 and 8 above would not be eligible for this process. Up to five Centres can be selected and once done so, a letter of convocation is to be distributed by the General Secretary to convene the Appeal.

12. The General Secretary shall thereafter, at the earliest possible time, circulate a list of the names of such nominees to all Road Race Clubs having held a Permit and organized an event in the discipline covered by the Committee in either the previous or current year.

13. The election will take place at an open meeting of the Committee to be held in November each year, supervised by either the General Secretary, a Director of the Company or a National Council delegate.

14. To be successful a candidate must secure a simple majority of the votes cast.

15. Voting will be limited to representatives of Clubs or Bodies having held a Permit and organised an event in the discipline covered by the Committee in either the previous or current year. Such representatives will each receive one vote (Proxy voting is permitted).

16. In the event of a tie a second ballot will be conducted in which only the two candidates receiving the greatest number of votes will take part. There will be no third ballot. In the event that there is no successful candidate after the second ballot a further election will take place at the next meeting of the Committee.

17. The number of votes cast for each candidate will be recorded in the minutes.

3. two persons nominated and appointed by the Non-Territorial Board (NTB);

4. one person nominated and appointed by the Road Race Group of the Motorcycle Industry Association (MCI);

5. one person nominated and appointed by the Motorcycle Racing Control Board Ltd (MCRCB);

6. one person nominated by the Association of Motor Racing Circuit Owners (AMRCO);

7. one person nominated and appointed by the Motorcycle Promoters Committee (MRPC);

8. each of the members appointed by AMRCO, MCI, MCRCB and MRPC shall be funded by his or her appointing body. Their appointments must be notified in writing to the General Secretary of the ACU Ltd. The General Secretary shall thereafter circulate the names of appointees to

all members of the National Council and Secretaries of Local Centres, for information.

The appointed members will hold office until replaced by the appointing body by notice in writing at any time to the General Secretary of the ACU Ltd.

9. The five Committee members elected or appointed by the NTB under this rule (3.1.1.1 and 3.1.2.1) shall have the right to appoint a Chairman from among such five members. A Deputy Chairman shall then be appointed by the Committee as a whole from among the remaining eight members of the Committee. Otherwise the general rules governing appointments of the Sport Chairmen at rules (7) to (9) (inclusive) shall govern their appointments. The Deputy Chairman may only act as Chairman on a temporary basis.

10. The term of office for elected members shall be a maximum of three years. A candidate may stand for re-election and subject to securing a simple majority may stand unopposed.

4 MOTOCROSS COMMITTEE

1. **Terms of Reference.** The Motocross Committee shall be responsible for the regulation and development of Motocross and shall consist of:

1. Six persons elected by the National Council.

2. Two persons appointed by the Directors following nomination by the Motocross Committee to represent Youth sport.

2. The election of persons to fill the annual vacancies on the Motocross Committee shall take place at a general meeting of the National Council in any year, and appointees shall assume office on 1st January of the following year. Retiring members shall do so on the preceding 31st December. Should vacancies become available, elections can take place at any National Council meeting.

3. Nominations for membership of the Motocross Committee may be made by Affiliated Local Motorcycle Clubs (endorsed by Local Centres), Local Centres/ACU and Non-Territorial Clubs. These nominations must be completed and reach ACU Head Office not later than 31st August in each year, subject to the following provisions:

1. Nominations submitted by Affiliated Local Motorcycle Clubs must be endorsed only by either the Centre Chairman or Centre Secretary.
 2. Nominations submitted by a Local Centre must be endorsed only by either the Centre Chairman or Centre Secretary.
 3. Nominations submitted by a Non-Territorial Club must be endorsed only by either the Non-Territorial Board Chairman or Secretary.
 4. Nominations submitted by a Recognised Promoter must be endorsed only by the NTB/a Centre Chairman or a Centre Secretary.
 5. Nominations can be sent by post or email. If sent by post, the nomination should be marked 'Election Paperwork' and sent to ACU Head Office, ACU House, Wood Street, Rugby, Warks, CV21 2YX. If sent by email, the nomination should be emailed to neil@acu.org.uk and the same email copied to dw@acu.org.uk. An acknowledgement will be sent by return once the nomination has been received. Nominations must be sent in good time as to reach ACU Head Office by 31st August in each year. Any nominations received after this date will not be accepted.
 6. The Board of Directors reserve the right to refuse a nomination for the Board if they have reason to believe the nomination would be detrimental to the ACU and/or motorcycle sport in general. Once the refusal of a candidate's nomination has been decided, the General Secretary will convene a meeting within 14 days between nominated members of the Board of Directors (a maximum of three) and a National Council Panel to explain the decision to refuse a candidate's nomination.
 7. The National Council Panel will be selected by Ballot. Two Members of Staff not directly involved with the National Council or the election process would conduct the selection. The Centre(s) who had endorsed the nomination would not be eligible for this process. Five Centres will be selected and once done so, a letter of convocation to be distributed by the General Secretary to arrange said meeting.
 8. Following the meeting between the nominated members of the Board of Directors/ National Council Panel, a person (from the National Council Panel) will be nominated to write to the Centre(s) who have endorsed the nomination outlining the reasons why a candidate's nomination has been refused.
 9. The Centre(s) who have endorsed the candidate's nomination will then decide whether to withdraw the candidate's nomination or continue to support the nomination.
 10. Should the Centre(s) decide to continue their support of the candidate's nomination, the candidate can appeal in writing accompanied with an Appeal Fee of £300.00 to the General Secretary within five days from the date of the meeting between the Board of Directors and the National Council Panel. The General Secretary will then convene a National Council Panel (five members), to hear the Appeal and if successful the nomination can be accepted for the next election process in that year, provided the nomination is submitted in accordance with the Rules of the Union. Members of the Board of Directors (a maximum of three) would also be invited to attend to give reasons for refusing the nomination in the first instance.
 11. The National Council Panel will be selected by Ballot. Two Members of ACU Staff not directly involved with the National Council or the election process would conduct the selection. The Centre(s) who had endorsed the nomination would not be eligible for this process and also those Centre(s) involved in the process outlined at paras 7 and 8 above would not be eligible for this process. Up to five Centres can be selected and once done so, a letter of convocation is to be distributed by the General Secretary to convene the Appeal.
4. The General Secretary shall thereafter, at the earliest possible time, circulate a list of the names of such nominees to all Members of the National Council and to Centre Secretaries/SACU.
 5. The six Committee members elected by the National Council shall have the right to appoint a Chairman from among such six elected members. A Deputy Chairman shall then be elected

- by the Committee from among the remaining five members of the Committee. Otherwise the general rules governing appointments of the Sport Chairmen at Rules C (7) to (9) (inclusive) shall govern their appointments. The Deputy Chairman may only act as Chairman on a temporary basis.
6. The term of office for the six elected members shall be for a maximum period of three years commencing on the 1st January in any year following appointment. A candidate may stand for re-election by submitting his nomination in accordance with Rule C.4.3 and subject to securing the requisite number of votes may stand unopposed. Retiring members shall be eligible for re-election subject to Rule L.
 7. The two members appointed by the Directors, shall be for a period of one year only and shall not have voting rights.
 8. The Motocross Committee may also invite person(s) with specialist knowledge to attend any meeting of the Committee, but such person(s) shall not have voting rights.
 9. A member of the Motocross Committee may not serve on any other discipline Committee or on the Board of Directors subject to the provisions of Rule E.1. An individual wishing to be considered for election to the Motocross Committee can only be nominated for that Committee. Nominations for other Sport Committees or the Board of Directors will not be accepted in accordance with Rule C3 above.
 10. A sub-committee of four members will be responsible for the management and organisation of the British Youth Motocross Championships, youth training and development and to incorporate the management and organisation of youth international events and representative teams. The sub committee may also invite person(s) with specialist knowledge to attend any meeting of the Committee, but such person(s) shall not have voting rights.
 1. Two members of the sub-committee will be the members nominated to the Motocross Committee, and the two other persons will be appointed by the Motocross Committee. The two members appointed by the Motocross Committee shall be for a period of one year only and shall not have voting rights.
 2. The Chairman of the sub-committee will be a member of the Motocross Committee. The Vice Chairman of the sub-committee will be selected from the remaining three appointed sub-committee members.

5 TRIALS AND ENDURO COMMITTEE

1. **Terms of Reference.** The Trials and Enduro Committee shall be responsible for the regulation and development of the Trials and Enduro disciplines and shall consist of eight persons elected by the National Council.
2. The appointment of persons to fill the annual vacancies on the Trials & Enduro Committee shall take place at a general meeting of the National Council in any year, and appointees shall assume office on 1st January of the following year. Retiring members shall do so on the preceding 31st December. Should vacancies become available, elections can take place at any National Council meeting.
3. Nominations for membership of the Trials & Enduro Committee may be made by Affiliated Local Motorcycle Clubs (endorsed by Local Centres), Local Centres/SACU and Non-Territorial Clubs. These nominations must be completed and reach ACU Head Office not later than 31st August in each year, subject to the following provisions:
 1. Nominations submitted by Affiliated Local Motorcycle Clubs must be endorsed only by either the Centre Chairman or Centre Secretary.
 2. Nominations submitted by a Local Centre must be endorsed only by either the Centre Chairman or Centre Secretary.
 3. Nominations submitted by a Non-Territorial Club must be endorsed only by either the Non-Territorial Board Chairman or Secretary.

4. Nominations submitted by a Recognised Promoter must be endorsed only by the NTB/a Centre Chairman or a Centre Secretary.
 5. Nominations can be sent by post or email. If sent by post, the nomination should be marked 'Election Paperwork' and sent to ACU Head Office, ACU House, Wood Street, Rugby, Warks, CV21 2YX. If sent by email, the nomination should be emailed to neil@acu.org.uk and the same email copied to dw@acu.org.uk. An acknowledgement will be sent by return once the nomination has been received. Nominations must be sent in good time as to reach ACU Head Office by 31st August in each year. Any nominations received after this date will not be accepted.
 6. The Board of Directors reserve the right to refuse a nomination for the Board if they have reason to believe the nomination would be detrimental to the ACU and/or motorcycle sport in general. Once the refusal of a candidate's nomination has been decided, the General Secretary will convene a meeting within 14 days between nominated members of the Board of Directors (a maximum of three) and a National Council Panel to explain the decision to refuse a candidate's nomination.
 7. The National Council Panel will be selected by Ballot. Two Members of Staff not directly involved with the National Council or the election process would conduct the selection. The Centre(s) who had endorsed the nomination would not be eligible for this process. Five Centres will be selected and once done so, a letter of convocation to be distributed by the General Secretary to arrange said meeting.
 8. Following the meeting between the nominated members of the Board of Directors/ National Council Panel, a person (from the National Council Panel) will be nominated to write to the Centre(s) who have endorsed the nomination outlining the reasons why a candidate's nomination has been refused.
 9. The Centre(s) who have endorsed the candidate's nomination will then decide whether to withdraw the candidate's nomination or continue to support the nomination.
 10. Should the Centre(s) decide to continue their support of the candidate's nomination, the candidate can appeal in writing accompanied with an Appeal Fee of £300.00 to the General Secretary within five days from the date of the meeting between the Board of Directors and the National Council Panel. The General Secretary will then convene a National Council Panel (five members), to hear the Appeal and if successful the nomination can be accepted for the next election process in that year, provided the nomination is submitted in accordance with the Rules of the Union. Members of the Board of Directors (a maximum of three) would also be invited to attend to give reasons for refusing the nomination in the first instance.
 11. The National Council Panel will be selected by Ballot. Two Members of ACU Staff not directly involved with the National Council or the election process would conduct the selection. The Centre(s) who had endorsed the nomination would not be eligible for this process and also those Centre(s) involved in the process outlined at paras 7 and 8 above would not be eligible for this process. Up to five Centres can be selected and once done so, a letter of convocation is to be distributed by the General Secretary to convene the Appeal.
4. The General Secretary shall thereafter, at the earliest possible time, circulate a list of the names of such nominees to all Members of the National Council and to Centre Secretaries/SACU.
 5. The Committee members shall have the right to appoint a Chairman and Deputy Chairman from among such eight elected members. Otherwise the general rules governing appointments of the Sport Committee Chairmen at Rules C (7) to (9) (inclusive) shall govern their appointments. The Deputy Chairman may only act as Chairman on a temporary basis.
 6. The term of office for each of the eight elected Members shall be for a maximum period of three years commencing from the 1st January in any year following appointment. A candidate may stand for re-election by submitting his nomination in accordance with Rule C.5.3 and subject to

securing the requisite number of votes may stand unopposed. Retiring members shall be eligible for re-election subject to Rule L.

7. The Trials & Enduro Committee may also invite person(s) with specialist knowledge to attend any meeting of the Committee, but such person(s) shall not have voting rights.
8. A member of the Trials & Enduro Committee may not serve on any other discipline Committee or on the Board of Directors subject to the provisions of Rule E.1. An individual wishing to be considered for election to the Trials & Enduro Committee can only be nominated for that Committee. Nominations for other Sport Committees or the Board of Directors will not be accepted in accordance with Rule C3 above.

6 TRACK RACING COMMITTEE

1. **Terms of Reference.** The Track Racing Committee shall be responsible for the regulation and development of Track Racing and shall consist of six persons elected by the National Council.
2. The appointment of persons to fill the annual vacancies on the Track Racing Committee shall take place at a general meeting of the National Council in any year, and appointees shall assume office on 1st January of the following year. Retiring members shall do so on the preceding 31st December. Should vacancies become available, elections can take place at any National Council meeting.
3. Nominations for membership of the Track Racing Committee may be made by Affiliated Local Motorcycle Clubs (endorsed by Local Centres), Local Centres/SACU and Non-Territorial Clubs. These nominations must be completed and reach ACU Head Office not later than 31st August in each year, subject to the following provisions:
 1. Nominations submitted by Affiliated Local Motorcycle Clubs must be endorsed only by either the Centre Chairman or Centre Secretary.
 2. Nominations submitted by a Local Centre must be endorsed only by either the Centre Chairman or Centre Secretary.
 3. Nominations submitted by a Non-Territorial Club must be endorsed only by either the Non-Territorial Board Chairman or Secretary.
 4. Nominations submitted by a Recognised Promoter must be endorsed only by the NTB/a Centre Chairman or a Centre Secretary.
 5. Nominations can be sent by post or email. If sent by post, the nomination should be marked 'Election Paperwork' and sent to ACU Head Office, ACU House, Wood Street, Rugby, Warks, CV21 2YX. If sent by email, the nomination should be emailed to neil@acu.org.uk and the same email copied to dw@acu.org.uk. An acknowledgement will be sent by return once the nomination has been received. Nominations must be sent in good time as to reach ACU Head Office by 31st August in each year. Any nominations received after this date will not be accepted.
 6. The Board of Directors reserve the right to refuse a nomination for the Board if they have reason to believe the nomination would be detrimental to the ACU and/or motorcycle sport in general. Once the refusal of a candidate's nomination has been decided, the General Secretary will convene a meeting within 14 days between nominated members of the Board of Directors (a maximum of three) and a National Council Panel to explain the decision to refuse a candidate's nomination.
 7. The National Council Panel will be selected by Ballot. Two Members of Staff not directly involved with the National Council or the election process would conduct the selection. The Centre(s) who had endorsed the nomination would not be eligible for this process. Five Centres will be selected and once done so, a letter of convocation to be distributed by the General Secretary to arrange said meeting.
 8. Following the meeting between the nominated members of the Board of Directors/ National Council Panel, a person (from the National Council Panel) will be nominated

to write to the Centre(s) who have endorsed the nomination outlining the reasons why a candidate's nomination has been refused.

9. The Centre(s) who have endorsed the candidate's nomination will then decide whether to withdraw the candidate's nomination or continue to support the nomination.

10. Should the Centre(s) decide to continue their support of the candidate's nomination, the candidate can appeal in writing accompanied with an Appeal Fee of £300.00 to the General Secretary within five days from the date of the meeting between the Board of Directors

and the National Council Panel. The General Secretary will then convene a National Council Panel (five members), to hear the Appeal and if successful the nomination can be accepted for the next election process in that year, provided the nomination is submitted in accordance with the Rules of the Union. Members of the Board of Directors (a maximum of three) would also be invited to attend to give reasons for refusing the nomination in the first instance.

11. The National Council Panel will be selected by Ballot. Two Members of ACU Staff not directly involved with the National Council or the election process would conduct the selection. The Centre(s) who had endorsed the nomination would not be eligible for this process and also those Centre(s) involved in the process outlined at paras 7 and 8 above would not be eligible for this process. Up to five Centres can be selected and once done so, a letter of convocation is to be distributed by the General Secretary to convene the Appeal.

4. The General Secretary shall thereafter, at the earliest possible time, circulate a list of the names of such nominees to all Members of the National Council and to Centre Secretaries/SACU.
5. The Committee members shall have the right to appoint a Chairman and Deputy Chairman from among such six elected members. Otherwise the general rules governing appointments of the Sport Committee Chairmen at Rules C (7) to (9) (inclusive) shall govern their appointments. The Deputy Chairman may only act as Chairman on a temporary basis.
6. The term of office for each of the six elected Members shall be for a maximum period of three years commencing from the 1st January in any year following appointment. A candidate may stand for re-election by submitting his nomination in accordance with Rule C.6.3 and subject to securing the requisite number of votes may stand unopposed. Retiring members shall be eligible for re-election subject to Rule L.
7. The Track Racing Committee may also invite person(s) with specialist knowledge to attend any meeting of the Committee, but such person(s) shall not have voting rights.
8. A member of the Track Racing Committee may not serve on any other discipline Committee or on the Board of Directors subject to the provisions of Rule E.1. An individual wishing to be considered for election to the Track Racing Committee can only be nominated for that Committee. Nominations for other Sport Committees or the Board of Directors will not be accepted in accordance with Rule C3 above.

7 SPEEDWAY CONTROL BUREAU

1. **Terms of Reference.** The ACU has established The Speedway Control Bureau (SCB) as a Committee of the ACU for the governance of the sport of Speedway within its territories, in conjunction with BSPA.
2. The ACU shall be exclusively responsible for the judicial functions of the sport of Speedway in accordance with the National Sporting Code and the Speedway Regulations.
3. The SCB shall be responsible for the regulation and development of Speedway and shall consist of:
 1. Two persons nominated and appointed by ACU Ltd
 2. Two persons nominated and appointed by the British Speedway Promoters Association (BSPA).
4. The four Bureau Members appointed under rule 7.1.3 above shall have the right to appoint

- an Independent Chairman to the Bureau. A Deputy Chairman shall then be appointed by the Bureau as a whole from the four Bureau Members.
5. The appointed Members will hold office until replaced by the appointing body by notice in writing at any time to the General Secretary ACU Ltd.
 6. The Bureau may also invite person(s) with specialist knowledge to attend any meeting of the Committee, but such person(s) shall not have voting rights.

CHAIRMEN AND DEPUTY CHAIRMEN OF SpORT COMMITTEES

8. Subject to the provisions concerning Road Race, Drag and Sprint Committee, each Sport Committee shall appoint from amongst its members a Chairman and a Deputy Chairman.
9. The appointment of Sport Committee Chairman and Deputy Chairman shall be presided over by a Director who shall have the casting vote. The term of office shall be for a maximum of three years dependant upon the expired period of his mandate from the National Council to serve as a Committee Member. A retiring Chairman or Deputy Chairman may stand for re-election.
10. A proposal to remove a Chairman of a Sport Committee from office as chairman shall be tabled only if approved by two-thirds or more of all the Committee, and shall only be carried with a majority of two thirds of all those present and voting.

MEMBERS OF SpORT COMMITTEES

11. Subject to the provisions concerning the Road Race, Drag and Sprint Committee, the National Council elect members to Sport Committees in accordance with article A6 of these Rules and in accordance with the relevant Terms of Reference of each Sport Committee as outlined in articles C4, C5 and C6. If any Sport Committee considers a person not to be acting in the best interests of the Committee, they may pass a motion of no confidence by a two-thirds majority. If this motion is passed, the Committee Chairman shall table the motion at the next meeting of the Board of Directors. Having looked fully into the circumstances, the Board of Directors may then recommend the removal of a person from a Sport Committee to the National Council. Should this be the case, the person will be suspended from that Sport Committee with immediate effect with no right of appeal, the suspension to be in place until the next meeting of the National Council. To be removed from a Sport Committee, the National Council will need an absolute majority of the votes cast (50% of the votes cast + 1, rounded up to the next highest whole number).

FREQUENCY OF SpORT COMMITTEE MEETINGS

12. Each Sport Committee shall meet at least four times a year and whenever summoned by the Chairman, or on requisition being made by one third or more of its members.

ADVISORY pANELS

13. The Advisory Panels shall be responsible for providing specialist advice and support to the ACU Ltd and the Sport Committees but shall not hold executive powers.
14. The Technical Panel shall consist of a Chairman appointed by the Board of Directors for confirmation by the National Council. Members of the Panel will be recommended by the Sport Committees for appointment by the Board of Directors. Selection will be based upon individuals possessing the appropriate skills, competencies and experience in their field. Other persons with relevant specialist knowledge pertinent to that agenda shall be invited by the Panel Chairman from time to time. From time to time the Chairman shall assemble a team of no more than four for the purposes of ACU helmet approval.
15. The Training & Development and Sustainable Event Management Panels shall consist of:
 1. one member appointed by each Sport Committee;
 2. other specialist members who may be appointed by the National Council; and

3. other persons with relevant specialist knowledge pertinent to that agenda may be invited by the Panel Chairman from time to time.
16. The Medical Advisory Panel shall consist of a Chairman appointed by the National Council (who need not be a medical doctor) and a number of qualified doctors, or suitably qualified medical personnel, appointed by the National Council in consultation with the Chairman of the Medical Panel and the Chairmen of the Sport Committees.
 17. The Panel of Adjudicators shall function in accordance with the ACU Ltd's National Sporting Code.

CHAIRMAN OF ADVISORY pANELS

18. The Board of Directors shall appoint a Chairman for each Advisory Panel for confirmation by the National Council. The term of office shall be for a maximum period of three years commencing on the 1st January in any year following appointment.

FREQUENCY OF ADVISORY pANEL MEETINGS

19. Each Advisory Panel shall meet whenever summoned by the Advisory Panel Chairman, or Chief Executive (or his equivalent) or on requisition being made by one third or more of its members.

ABSENTEES

20. Any Member who is absent from three programmed meetings of the Board of Directors, Sport Committee meetings, Sub-Committee or Advisory Panel meetings in any one year of which he is an appointed member without reasonable cause accepted by the Board, may forfeit his Membership of the Board of Directors, Sport Committee, Sub-Committee or Advisory Panel as the case may be.

D SUB-COMMITTEES

1. Each Sport Committee may appoint one or more sub-Committees and may with the prior approval of the Board delegate to them such powers as it may think fit. The members of such sub-Committees may include persons who are not Members of the ACU Ltd but who possess relevant specific skills, knowledge and expertise.
2. Sub-committees shall report to their appointing Sport Committee, and their decisions shall be subject to confirmation by that Committee. The appointing Sport Committee shall also appoint a sub-committee Chairman. The Chairman of the appointing Committee shall be eligible to attend any meeting of the sub-Committee without voting rights.

E BOARD OF DIRECTORS

1. There shall be up to twelve Directors elected to the Board. The composition of the Board will be: the Sport Committee Chairmen who become Directors as a result of their election to be Sport Committee Chairmen and six Directors elected from across the membership. A Finance Director/Advisor appointed by the Board as and when the Board see fit to do so. The Chairman and Deputy Chairman of the Board will be elected by and from the members of the Board. Each Director has an equal vote. The Chairman will be entitled to vote and will also hold the 'casting vote' where necessary. The appointments of Chairman and Deputy Chairman may be any one of the Directors except the Financial Director/Financial Advisor.
 1. The appointment of persons to fill the annual vacancies on the Board of Directors shall take place at a general meeting of the National Council in any year, and appointees shall assume office on 1st January of the following year. Retiring members shall do so on the preceding 31st December. Should vacancies become available elections can take place at any National Council meeting.
 2. Nominations for membership of the Board of Directors may be made by Affiliated Local

Motorcycle Clubs (endorsed by Local Centres), Local Centres/SACU and Non-Territorial Clubs. These nominations must be completed and reach ACU Head Office not later than 31st August in each year, subject to the following provisions:

1. Nominations submitted by Affiliated Local Motorcycle Clubs must be endorsed only by either the Centre Chairman or Centre Secretary.
 2. Nominations submitted by a Local Centre must be endorsed only by either the Centre Chairman or Centre Secretary.
 3. Nominations submitted by a Non-Territorial Club must be endorsed only by either the Non-Territorial Board Chairman or Secretary.
 4. Nominations submitted by a Recognised Promoter must be endorsed only by the NTB/a Centre Chairman or a Centre Secretary.
 5. Nominations can be sent by post or email. If sent by post, the nomination should be marked 'Election Paperwork' and sent to ACU Head Office, ACU House, Wood Street, Rugby, Warks, CV21 2YX. If sent by email, the nomination should be emailed to neil@acu.org.uk and the same email copied to dw@acu.org.uk. An acknowledgement will be sent by return once the nomination has been received. Nominations must be sent in good time as to reach ACU Head Office by 31st August in each year. Any nominations received after this date will not be accepted.
 6. The Board of Directors reserve the right to refuse a nomination for the Board if they have reason to believe the nomination would be detrimental to the ACU and/or motorcycle sport in general. Once the refusal of a candidate's nomination has been decided, the General Secretary will convene a meeting within 14 days between nominated members of the Board of Directors (a maximum of three) and a National Council Panel to explain the decision to refuse a candidate's nomination.
 7. The National Council Panel will be selected by Ballot. Two Members of Staff not directly involved with the National Council or the election process would conduct the selection. The Centre(s) who had endorsed the nomination would not be eligible for this process. Five Centres will be selected and once done so, a letter of convocation to be distributed by the General Secretary to arrange said meeting.
 8. Following the meeting between the nominated members of the Board of Directors/ National Council Panel, a person (from the National Council Panel) will be nominated to write to the Centre(s) who have endorsed the nomination outlining the reasons why a candidate's nomination has been refused.
 9. The Centre(s) who have endorsed the candidate's nomination will then decide whether to withdraw the candidate's nomination or continue to support the nomination.
 10. Should the Centre(s) decide to continue their support of the candidate's nomination, the candidate can appeal in writing accompanied with an Appeal Fee of £300.00 to the General Secretary within five days from the date of the meeting between the Board of Directors and the National Council Panel. The General Secretary will then convene a National Council Panel (five members), to hear the Appeal and if successful the nomination can be accepted for the next election process in that year, provided the nomination is submitted in accordance with the Rules of the Union. Members of the Board of Directors (a maximum of three) would also be invited to attend to give reasons for refusing the nomination in the first instance.
 11. The National Council Panel will be selected by Ballot. Two Members of ACU Staff not directly involved with the National Council or the election process would conduct the selection. The Centre(s) who had endorsed the nomination would not be eligible for this process and also those Centre(s) involved in the process outlined at paras 7 and 8 above would not be eligible for this process. Up to five Centres can be selected and once done so, a letter of convocation is to be distributed by the General Secretary to convene the Appeal.
3. The General Secretary shall thereafter, at the earliest possible time, circulate a list of the

names of such nominees to all Members of the National Council and to Centre Secretaries/ SACU.

4. The Directors of the Board shall have the right to appoint a Chairman and Deputy Chairman from among such ten elected/appointed members. Otherwise the general rules governing appointments of the Sport Committee Chairmen at Rules C (7) to (9) (inclusive) shall govern their appointments. The Deputy Chairman may only act as Chairman on a temporary basis.
5. The term of office for each of the ten elected/appointed Members shall be for a maximum period of three years commencing from the 1st January in any year following appointment. A candidate may stand for re-election by submitting his nomination in accordance with Rule E (2) and subject to securing the requisite number of votes may stand unopposed. Retiring members shall be eligible for re-election subject to Rule L.
2. If the Chairman of the Company is an elected Sport Committee Chairman, and that Committee see fit to remove him as their Chairman, the Board may elect to retain the individual as the Chairman of the Company for the duration of the remainder of his appointment and increase the number of Directors by one for that period.
3. In addition to the customary roles and responsibilities of a Company's Board of Directors, the Board shall be responsible for the formulation of strategy relating to motorcycle sporting, recreational and leisure activity and the subsequent production of policy and procedure.
4. The Board shall co-ordinate and monitor the implementation of those policies and procedures by the relevant Committee/s and/or Panel/s. It will achieve this by:
 1. Controlling the national activity of motorcycling in accordance with the Rules of the ACU Ltd and the National Sporting Code.
 2. Exercising authority to formulate strategy and policy for the development and management of sporting disciplines.
 3. Producing the vision, aims and mission statements of the ACU Ltd.
 4. Preparing annual and longer term budget submissions for the governance and development of motorcycle sporting, recreational and leisure activity.
 5. Setting up and managing working groups and sub-committees as appropriate from time to time.
 6. Prioritising the sporting, recreational and leisure activity funded centrally by the ACU Ltd.
5. The Board shall receive the recommendations of the various Sport Committees and Panels regarding representatives/delegates of the ACU Ltd to the Fédération Internationale de Motocyclisme Europe (FIME) and the Fédération Internationale de Motocyclisme (FIM). The Board shall then submit such nominations, if supported, to the National Council for ratification.
6. In accordance with Rule I (2) the Board may suspend any FIME or FIM delegate with the right of Appeal to the National Council, or if ratified by National Council, to the Panel of Adjudicators.
7. The Board shall receive the recommendations of the various Sport Committees and Panels regarding changes to the National Sporting Code, Rules of the ACU Ltd and all other parts of the annual Handbook. If supported the Board shall then consult the National Council giving reasonable notice for such consultation prior to the Rules being adopted.

F INTERESTS

The provisions of Articles 46 and 47 of the Articles of Association of the ACU Ltd shall be deemed to apply, mutatis mutandis, to members of any Committee, sub-Committee, and advisory panel as they apply to Directors of ACU Ltd.

G FINANCES

1. The ACU Ltd's financial year shall commence on 1st January.
2. Each Group shall be responsible for its own finances and shall be accountable to the Board.

3. The ACU Ltd shall maintain a bank account with a United Kingdom clearing bank approved by the Board.
4. Automated payments and Cheques drawn on the ACU Ltd's accounts may be signed by any one of the Signatories approved and authorised by the Board to sign save that automated payments and cheques in excess of £3,000 must be signed by any two of them.
5. The Finance Manager shall obtain prior approval of the Board before authorising anything other than minor changes in the Company's investments.
6. The Finance Manager shall present the accounts together with supporting documentation to the ACU Ltd's Auditor.
7. The Finance Manager shall present a written summary of the ACU Ltd's financial situation to each meeting of the Board
8. In the event of ACU Ltd becoming wound up, disbanded or ceasing to exist, all monies and properties of the ACU Ltd shall be deemed to be the property of the Members of the ACU Ltd at the date that the ACU Ltd is wound up or dissolved or ceases to exist and shall be distributed to the Members in proportion to the number of Local Motorcycle Clubs in good standing and Affiliated to each Member.

H SUBSCRIPTIONS

1. Affiliated Local Motorcycle Clubs, Non-Territorial Clubs, Associate Members, and Recognised Associations ("individually known as "Group" and collectively as "Groups") shall each pay to the ACU Ltd an annual subscription of such sum as shall be recommended by the Board of Directors and confirmed by a simple majority of Members present and entitled to vote at a General Meeting of the ACU Ltd. This will result in abstentions being included in the calculation.
2. The annual subscription shall be payable on affiliation to the ACU Ltd on signature of the Affiliation Agreement and thereafter on the first day of January in each year ("the Renewal Date").
3. Any Group that has not paid its subscription fee by 1st March following the Renewal Date shall be notified in writing that its Membership will be suspended immediately unless payment is received by 31st January in the same year. Should the subscription fee remain unpaid, such Group shall be suspended until the subscription is paid.
4. Liability for payment of the subscription shall remain enforceable as a debt against the Group until such time as the ACU Ltd, in its sole discretion, gives notice of cancellation of membership to the Group.
5. The annual subscription fee shall be set at a rate which will produce an income appropriate for maintaining the activities of the ACU Ltd as a whole and ensuring its financial independence and shall be calculated according to the total number of enrolled Groups at the date of application. Where the annual subscription fee is to be paid on 1st January, total membership figures from the previous year shall be used to calculate the fee.
6. The subscription fee to be paid by each Group shall comprise the following:
 - a. an amount to support the ACU Ltd and its activities through the Committees; and
 - b. an amount or amounts to support the Group or Groups to which the particular member belongs.
7. The Financial Director shall collect subscriptions and distribute the amounts payable in respect of each Group to the relevant Group Treasurers, and shall retain the remainder in the ACU Ltd account.

I CESSATION OF MEMBERSHIP

1. An Individual Subscribed Member, Associate Member or Honorary Member may resign from the ACU Ltd by notice in writing to the ACU Ltd.
2. The Board may suspend any such member whose conduct in its opinion is contrary to the

interests of the ACU Ltd, and who fails to comply with the Rules and Bye-Laws. The Board may recommend to the National Council that the suspended member be expelled from the ACU Ltd. No member shall be expelled by the National Council unless and until the individual has been given notice in writing of the resolution to expel the individual and been given an opportunity to make representations orally or in writing to the National Council. No member is to remain under suspension for any period greater than two meetings of the National Council.

J ACU LTD MOTORCYCLING FORUM

If appropriate, at least once every two years the Members shall convene an open forum, which shall be advisory only, which all Affiliated Clubs shall be eligible to be represented by one delegate, in order to discuss matters of common interest across all activities.

K SPORT FORUMS

If appropriate, at least once a year each Sport Committee shall convene an open forum, which shall be advisory only, which all Affiliated Clubs shall be eligible to be represented by one delegate, in order to discuss matters of particular interest to each sport.

L AGE RESTRICTIONS

No person shall be elected or appointed as a member of the Board of Directors, National Council, Sport Committees or Panels, after reaching the age of 73. Any person who reaches the age of 73 whilst serving as a member of any of the aforementioned bodies may remain in office only until the end of the year in which the age of 73 is reached. The maximum period of election or appointment in any office within ACU Ltd shall be three years, with re-election possible subject to the provision of this Rule. The only exception being the Panel of Adjudicators.

M DEFINITIONS

1. Unless otherwise specified, words and expressions defined in the Memorandum and Articles of Association of the ACU Ltd shall have the same meaning in these rules and Bye-Laws.
2. "Affiliation Agreement" means a standard form agreement of affiliation to the ACU Ltd (as approved by the Board from time to time); and "Affiliation" and "Affiliated" shall be construed accordingly as referring to a Local Centre Club or the person who has entered into an Affiliation Agreement with the ACU Ltd.

THE AUTO-CYCLE UNION (ACU) LIMITED MODEL LOCAL CENTRE BYE-LAWS

To be read in association with the Rules and Bye-Laws of the ACU Ltd

1. ADMINISTRATION

- 1.1 An Annual Meeting of the Centre shall be held on a date to be fixed by the Centre Board, once in each calendar year. At least 21 days prior to the date of this Annual Meeting the Secretary of the Centre shall send to each Affiliated Local Motorcycle Club in the Centre a preliminary notice of the date of the meeting and a request for the nomination of the following officers for the ensuing year:
 - President
 - Chairman
 - Vice-Chairmen (not more than two)
 - Honorary Treasurer
 - Other officers as necessary
- 1.2 Nominations shall be sent to the Centre Secretary so as to be received not later than 14 days prior to the date of the Annual Meeting. Such nominations shall be set out in the

- notice convening the Annual Meeting, a copy of which shall be sent to each Affiliated Local Motorcycle Club in the Centre not later than 7 days prior to the date of the meeting.
- 13 At the Annual Meeting of the Centre the report of the Board and a report of the Treasurer for the past year shall be presented and the officers for the ensuing year shall be elected from amongst the nominees by a ballot in which each Affiliated Local Motorcycle Club represented at the meeting shall have two votes and an additional vote for every 100 members or part of 100 members above the first 100 members. No nomination shall be placed before the meeting unless written notification of acceptance has been received from the nominee. To arrive at the voting power of the Club the membership of that Club as reported on the previous 31st December shall be taken.
- 14 The officers elected hold office for one year and, together with the appointee representing the Local Centre at general meetings of the ACU Ltd, shall form the Emergency Committee of the Centre Board.

2. BOARD

- 2.1 The affairs of the Centre shall be managed by a Board composed of the Officers of the Centre and representatives from each Affiliated Local Motorcycle Club and Group in the Centre.
- 2.2 The representatives of the Affiliated Local Motorcycle Clubs shall be elected by their Clubs in the proportion of two members for a Club membership not exceeding 100 and one additional representative for 100 members or part of 100 members above the first 100 members.
- 2.3 The representatives of the Groups shall be appointed by the Affiliated Local Motorcycle Clubs forming a Group and shall not exceed in number one representative for each Group of not more than ten Affiliated Local Motorcycle Clubs and a second representative for any larger Group.
- 2.4 The quorum for a meeting of the Board shall be five, each member shall be entitled to one vote, and in case of an equality of votes, the Chairman shall have a casting vote.

3. CHANGE OF REPRESENTATION

An Affiliated Local Motorcycle Club or Group shall have the power to change its representatives on the Board at any time, so long as the number of such representatives does not exceed that to which it is entitled under Article 2.2 or 2.3 of these Bye-Laws such change to take effect on and from the date of receipt of notice by the Secretary of the Centre.

4. SUB-COMMITTEES OF THE BOARD

- 4.1 The Board may appoint Sub-Committees, and may delegate to them such powers as it may think fit to prescribe in the terms of reference. Such Sub-Committees may comprise persons who are not members of the Board or of the Local Centre.
- 4.2 The Sub-Committees shall report to the Board, and their recommendations shall be subject to confirmation by the Board, except in cases where they are given full power to act.
- 4.3 Sub-Committees shall appoint their own Chairmen and Vice-Chairmen. The Chairman and Vice-Chairman of the Board shall be members of every Sub-Committee, except in special cases where the Board may otherwise order.
- 4.4 Additional members may be appointed, or vacancies may be filled on Sub-Committees by the Board.

5. EMERGENCY COMMITTEE

The Emergency Committee as constituted according to 1.4 of these Bye-Laws shall have power to deal with matters of urgency which may arise from time to time, subject always to its proceedings being confirmed at a subsequent meeting of the Board.

6. FINANCE

Subscription fees from the individual Members of Affiliated Local Motorcycle Clubs within a Local

Centre (less any amount retained by the ACU headquarters under Rule (B) (20) of the Rules and Bye-laws of the ACU Ltd) and any other income received shall be the property of the Centre, and shall be expended from time to time as the Board deems fit in the furtherance of the objects of the Centre.

7. SECRETARY

- 7.1 At the first meeting of the Board in each year a Secretary shall be appointed, either in an honorary capacity or at such remuneration as may be fixed by the Board. The Secretary shall remain in office until the first meeting of the Board in the succeeding year unless previously released from office by the Board. The duties of the Secretary shall include:
- a. responsibility for the recording of proceedings of all business transacted at meeting of the Board and Sub-Committees of the Board;
 - b. responsibility for the production of minutes of all meetings and for submitting them for confirmation at the next following meeting of the Board or Sub-Committee as the case may be;
 - c. responsibility for all correspondence in connection with the work of the Centre.
- 7.2 The Treasurer, on the instructions of the Board, shall refund the Secretary's out-of-pocket expenses incurred in attending meetings of the Board or Sub-Committees or Competitions promoted by the Centre, and other out-of-pocket expenses.

8. MEETINGS

- 8.1 Meetings of the Board shall be held on such dates at such times and at such venues as the Board decides from time to time.
- 8.2 The Chief Executive of the ACU Ltd, or his deputy, shall have the right to be present at all meetings of the Board or Sub-Committees of the Board, with all privileges of membership other than the right to vote.

9. WINDING-Up

In the event of the Centre becoming wound-up, disbanded or ceasing to exist, all monies and properties of the Centre shall be deemed to be the property of the Affiliated Local Motorcycle Clubs which are members of the Centre at the date on which the Centre is wound up or dissolved or ceases to exist, and shall be used in any manner thought fit by such clubs.

10. LIMITED COMPANIES

Where a Centre is a limited company and where the Memorandum and Articles of Association are inconsistent with these Bye-laws, the Memorandum and Articles shall prevail, reasonably and properly incurred by the Secretary.

